

Feasibility of Energy Harvesting Using a Piezoelectric Tire

by

Christopher Malotte

A Thesis Presented in Partial Fulfillment
of the Requirements for the Degree
Master of Science in Technology

Approved November 2012 by the
Graduate Supervisory Committee:

Arunachalanadar Madakannan, Chair
Devarajan Srinivasan
Bradley Rogers

ARIZONA STATE UNIVERSITY

November 2012

ABSTRACT

While the piezoelectric effect has been around for some time, it has only recently caught interest as a potential sustainable energy harvesting device. Piezoelectric energy harvesting has been developed for shoes and panels, but has yet to be integrated into a marketable bicycle tire. For this thesis, the development and feasibility of a piezoelectric tire was done. This includes the development of a circuit that incorporates piezoceramic elements, energy harvesting circuitry, and an energy storage device. A single phase circuit was designed using an ac-dc diode rectifier. An electrolytic capacitor was used as the energy storage device. A financial feasibility was also done to determine targets for manufacturing cost and sales price. These models take into account market trends for high performance tires, economies of scale, and the possibility of government subsidies. This research will help understand the potential for the marketability of a piezoelectric energy harvesting tire that can create electricity for remote use. This study found that there are many obstacles that must be addressed before a piezoelectric tire can be marketed to the general public. The power output of this device is miniscule compared to an alkaline battery. In order for this device to approach the power output of an alkaline battery the weight of the device would also become an issue. Additionally this device is very costly compared to the average bicycle tire. Lastly, this device is extreme fragile and easily broken. In order for this device to become marketable the issues of power output, cost, weight, and durability must all be successfully overcome.

DEDICATION

To my parents and my lovely wife, Nicole. I could not have done this without
your constant support

ACKNOWLEDGMENTS

I would like to acknowledge and thank the GPSA for the jumpstart grant. The funding that they provided helped to make this research possible. I would also like to thank all of my graduate committee; Dr. Kannan (Chair), Dr. Rogers, & Dr. Srinivasan.

TABLE OF CONTENTS

	Page
LIST OF TABLES.....	v
LIST OF FIGURES.....	vi
CHAPTER	
1 INTRODUCTION.....	1
2 LITERATURE REVIEW	2
3 DESCRIPTION OF RESEARCH	7
Development of Piezoelectric Tire.....	7
Feasibility and Physical Testing.....	10
Financial Analysis.....	13
4 RESULTS	14
Physical Testing.....	14
Financial Testing.....	15
5 CONCLUSION	20
Advantages.....	20
Disadvantage.....	21
6 RECOMMENDATIONS.....	23
REFERENCES	24
APPENDIX	
1 CURRENT STATE OF THE MARKET AND FUTURE OUTLOOK.....	27

LIST OF TABLES

Table	Page
1. Year When Various Scenarios Reach \$1000/W	18

LIST OF FIGURES

Figure		Page
1.	Thomson Quadrant Electrometer [2].....	2
2.	Power Density Versus Voltage for Various Energy Devices[8]	4
3.	Piezoelements.....	7
4.	Wired Piezoelements.....	8
5.	Electrical Schematic.....	8
6.	Nichocon 1000 μ F Electrolytic Capacitor.....	9
7.	Piezoelectric Tire.....	10
8.	Electra Bicycle with Piezoelectric Tire	10
9.	Owon PDS 505225 Oscilloscope	11
10.	Cen-tech Digital Multimeter	11
11.	Intitial Circuit Design Analysis Setup	12
12.	CBA III Battery Testing Device	12
13.	Discharge Profile of Supercapacitor.....	14
14.	Cost per GB of Storage over Time	16
15.	Cost per Watt of Solar Photovoltaics over Time	16
16.	Cost for Li-Ion Batteries over Time	16
17.	Possible Scenario for Cost of Piezoelectric Energy Harvesting Tire (Computational Memory).....	17
18.	Possible Scenario for Cost of Piezoelectric Energy Harvesting Tire (Photovoltaics and Li-Ion Battery).....	18

Chapter 1

INTRODUCTION

While the piezoelectric effect has been around for some time, it has only recently caught interest as a potential sustainable energy harvesting device. Piezoelectric energy harvesting has been developed for shoes and panels, but has yet to be integrated into a marketable bicycle tire. For this thesis, the development and feasibility of a piezoelectric tire was done. This includes the development of a circuit that incorporates piezoceramic elements, energy harvesting circuitry, and an energy storage device. A single phase circuit was designed using an ac-dc diode rectifier. An electrolytic capacitor was used as the energy storage device. A financial feasibility was also done to determine targets for manufacturing cost and sales price. These models take into account market trends for high performance tires, economies of scale, and the possibility of government subsidies. This research will help understand the potential for the marketability of a piezoelectric energy harvesting tire that can create electricity for remote use. This study found that there are many obstacles that must be addressed before a piezoelectric tire can be marketed to the general public. The power output of this device is miniscule compared to an alkaline battery. In order for this device to approach the power output of an alkaline battery the weight of the device would also become an issue. Additionally this device is very costly compared to the average bicycle tire. Lastly, this device is extreme fragile and easily broken. In order for this device to become marketable the issues of power output, cost, weight, and durability must all be successfully overcome.

Chapter 2

LITERATURE REVIEW

The piezoelectric effect has been around since the 1880s, discovered by Pierre Curie and Jacque Curie [1]. The piezoelectric effect is generation of electrical energy from mechanical stresses in certain particular crystals [2]. The Curie brothers discovered this effect in six crystal types: tourmaline, zinc, blende, boracites, topaz, calamine, and quartz [2]. In their experiment, the Curies connected two copper plates to a Thomson quadrant electrometer (figure 1 below) and placed these crystals in between the two plates. They then compressed the two copper plates and watched the electrometer. They found that when these crystals were compressed they produced an electric potential and when they were released they produced an electric current.

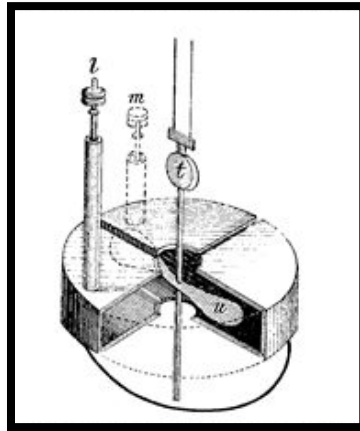

Figure 1: Thomson quadrant electrometer [2]

Currently, the piezoelectric effect is used in a number of applications including high voltage and power sources, sensors, actuators, frequency standardization, piezoelectric motors, reduction of vibration and noise, and infertility treatment [3]. In 2010, Acmite Market Intelligence valued the current

global demand for piezoelectric devices at approximately \$14.8 billion [3]. Industrial and manufacturing is the largest application market for piezoelectric devices, followed by the automotive industry, medical instruments, and the information and telecommunications industries [3]. The automotive industry primarily uses piezoelectric devices as sensors for air bags, air flow, and knocks. They also use piezoelectric devices for audible alarms, fuel atomizers, keyless door entry, and seat belt buzzers.

The vast majority of climate scientists agree that that global climate change is a fact and that humans are the main cause of global climate change [4]. One of the main causes of global climate change is carbon dioxide, produced by human activity. One of the largest producers of carbon dioxide are automobiles that run on internal combustion engines. As engines combust gasoline, they produce carbon dioxide, water and particulate materials as emissions. In the United States, transportation accounts for approximately 27 percent of total greenhouse gas emissions [5].

To help cut down on some of these greenhouse gas emissions, countries have adopted standards that increase the efficiency of vehicles. In 2009, the Obama administration increased the average vehicle fuel efficiency standard to 35.5 miles per gallon for the average vehicle sold in the United States [6].

Companies have adopted several new technologies to help meet these standards including natural gas, plug-in electric, fuel cell, and hybrid vehicles. By 2007, Toyota had sold nearly 1 million Toyota Priuses (a gasoline hybrid vehicle) [7]. These vehicles use batteries and electric motors to help make the traditional

internal combustion engine more efficient. One of the key technologies that helps make the hybrid more efficient is the use of regenerative braking. Regenerative braking uses the electric motor to charge supercapacitors (also known as electrolytic capacitors) as a means of braking, as opposed to the traditional braking using friction from the brake pads. Energy efficiency devices such as regenerative braking and piezoelectric tires could help make the traditional internal combustion engine more fuel efficient.

Recent interest in using piezoelectricity for energy harvesting as a sustainable power source has been documented by Chennault, et al. [8]. Chennault describes the power density of piezoelectric elements compared to other common forms of energy harvesting devices (Fig. 2 below). Piezoelectric elements have a very low power density compared to most energy harvesting devices. Chennault, et al. describe the possibilities for piezoelectric energy harvesting and various types of piezoelectric crystals that should be used.

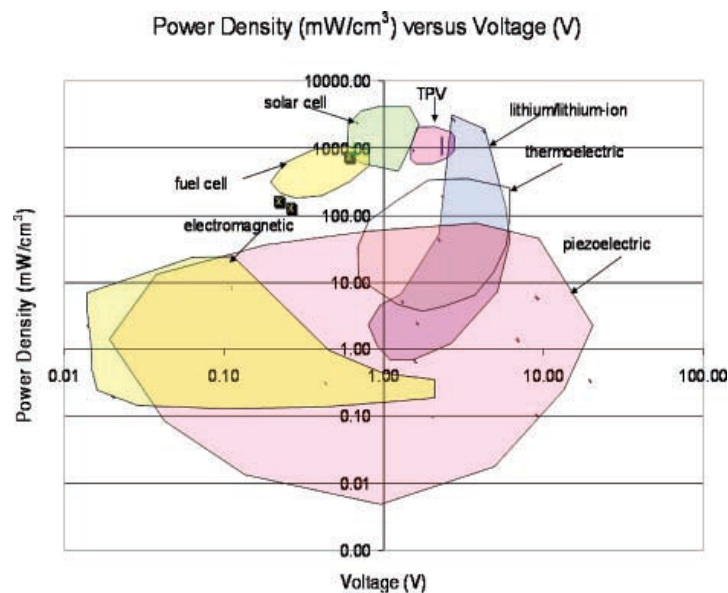

Figure 2: Power Density versus Voltage for Various Energy Devices [8]

The advances in energy harvesting using low profile piezoelectric transducers have been reviewed by Priya [9]. Piezoelectric energy harvesting for use as wireless sensors [10] and electricity generation from shoe compression [11] has been well documented in the past. In the shoe compression energy harvesting, CA Howells develops 4 “Heel Strike Units” that use piezoelectric elements to produce electricity. This work shows that piezoelectric devices can produce useable electricity even in low frequency vibrations. A piezoelectric tire will come into contact much more frequently than “Heel Strike Units”.

Piezoelectric sensors have been used in tires to sense low pressure and other tire vitals [12]. In these devices, the piezoelectric elements are used as sensors in conjunction with a battery. These sensors are able to tell if the tire pressure is low and can then transmit a signal to the car using Zigbee communication protocol. Using piezoelectric elements to harvest some of the energy lost to impact with the road could help power the piezoelectric tire pressure sensor and lose the need for a battery as currently designed.

The concept of using piezoelectric energy harvesting in tires, however, has not been thoroughly studied. This research would analyze the concept of harvesting energy using piezoceramic elements on bicycle tires.

The best design of a piezoelectric tire must be worked out before a thorough analysis of its efficiency as an electricity harvester can be done. Previous research by Jeong, et al., has shown the properties of multi-stack piezoelectric harvesting devices [13]. Design was informed by research on best array configurations for piezoelectric energy harvesting that has been analyzed by

Koyama and Nakamura [14]. With tire contact occurring at low frequencies, design also utilizes research done by Shen on piezoelectric energy harvesting device for low frequencies [15]. Further analysis must be done to determine the best layout of piezoelectric material to maximize durability and power.

An analysis of various types of piezoelectric energy harvesting devices in the recharging of batteries has been done by Sodano, Inman and Park [16]. Badel, et al., have done research to maximize the efficiency of battery recharging using piezoelectric energy harvesting devices [17]. Mingjie has done a thorough analysis of energy harvesting devices and their ability to interface with energy storage devices [18]. This study uses previous knowledge on energy storage to develop a proper energy storage device for the piezoelectric tire.

Rupp, Dunn, and Maute developed a numerical simulation to analyze piezoelectric energy harvesting systems with non-linear circuits [19]. Additionally, Shu and Lien investigated the optimal AC-DC power generation and showed that power depends on frequency, mass, natural frequency, mechanical damping ration and coupling coefficient [20]. The knowledge from these studies will help develop parameters for testing the piezoelectric tires.

Piezoelectric tires have the potential to be a renewable source of energy, utilizing energy that is currently being lost to heat and sound. Up to this point research has been done on piezoelectric energy harvesting on its own and piezoelectric sensors in tires, but has been lacking in using piezoelectric tires as a device for energy harvesting. This study helps to determine the physical and economic feasibility of a piezoelectric tire.

Chapter 3

DESCRIPTION OF RESEARCH

Development of Piezoelectric Tire

A piezoelectric energy harvesting device consists of four main components: (1) an energy harvester (piezoceramic element, aka piezoelement, piezoelectric cell or piezocrystal), (2) energy harvesting circuitry, (3) an energy storage device, and (4) the mechanical support structure (in this case the tire). The design and development of the piezoelectric tire was the first major phase. Informed by recent research, the piezoelectric tire was designed using a piezoceramic layer, a system of energy harvesting circuits, and supercapacitors for energy storage, and the tire itself.

The piezoelement that was chosen for this experiment is a Matsushita #WM-71A111M ceramic piezoelement that is 22mm diameter, and has an impedance of 2,000 ohm @ 1khz producing 106db (removed from casing). This was chosen for its cheap cost, availability, and physical characteristics. The piezoelements were assembled with 4 piezoelements in series and 12 of these circuits in parallel for a total of 48 cells (figure 3 & 4 below).

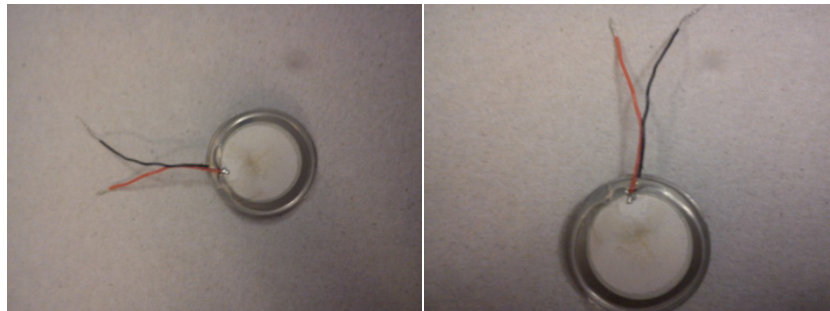

Figure 3: Piezoelements



Figure 4: Wired Piezoelements

Figure 5 (below) shows the designed circuit for the energy harvesting device. It contains the piezoelectric cells (shown as a circles with circle in the middle), an ac-dc conversion circuit, and a storage device (an electrolytic capacitor shown as a capacitor with a +). The schematic was developed using SmartDraw schematic drawing program.

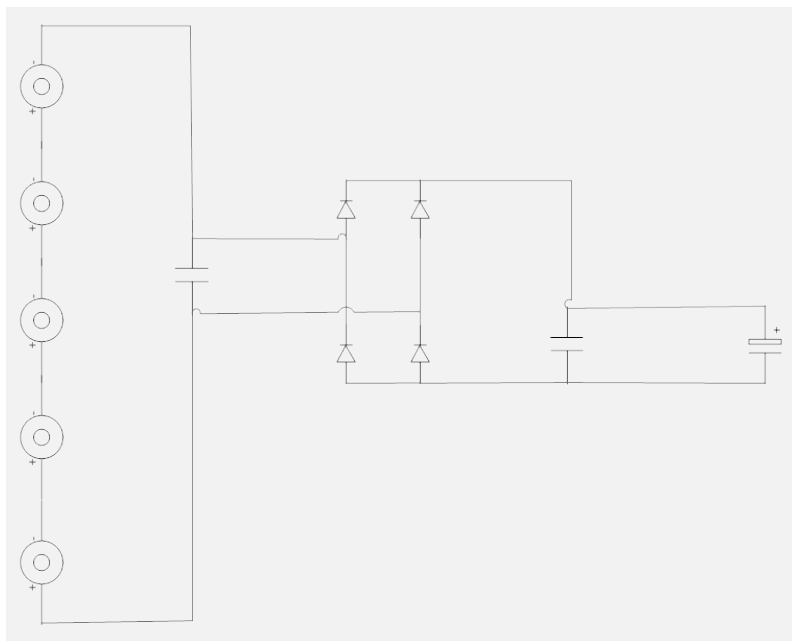

Figure 5: Electrical Schematic

The choice was between a traditional capacitor, a lithium ion rechargeable battery, a nickel metal hydride battery, and an electrolytic capacitor. An electrolytic capacitor (or supercapacitor) was chosen as the energy storage device for a number of reasons. The main reason is that electrolytic capacitors have the highest charge/discharge efficiency of the four choices. They also have the advantage that they can be shallowly charged and discharged without causing memory effect. The third reason for electrolytic capacitors is their long life cycle. Electrolytic capacitors can be charged/discharged up to 10,000 times. Lastly, electrolytic capacitors are small so they can fit inside a tire without causing major vibration and balance issues. A RadioShack Nichicon 1000 μF , 35 V, VX(M) electrolytic capacitor (figure 6 below) was chosen for its cost, availability, and physical characteristics.

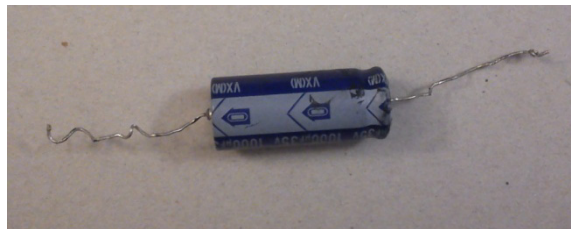

Figure 6: Nichicon 1000 μF Electrolytic Capacitor

A prototype of the tire was built using an existing bicycle tire (Electra 26'' x 2.5'' rubber tube tire, figure 7 below) and modifies the tire to include the piezoelectric elements, energy harvesting circuitry, and electrolytic capacitor. The piezoelements were taped to the outside of the tire and the wires were run along the spokes to reach the circuitry and storage device in the center of the wheel. The tire was then fit on a standard bicycle (Electra Bicycle Co. Beach Cruiser Bicycle, figure 7 below)



Figure 7: Piezoelectric Tire



Figure 8: Electra Bicycle with Piezoelectric Tire

Feasibility and Physical Testing

Physical feasibility of the piezoelectric tire was done in the electronics laboratory with the assistance of an OWON PDS 50225 multifunction oscilloscope (figure 9 below) and a Cen-Tech 7 function digital multimeter (figure 10 below) for primary analysis. A lab apparatus was set up to mimic the forces felt on the piezoelectric elements by the tire when attached to the bicycle

(figure 11 below). The energy harvested was initially be done by connecting a multifunction oscilloscope to the electrolytic capacitor inputs (capacitor was not connected) and analyzing the voltage that would be passed to the capacitor. Results from this portion of the feasibility study assisted in the development of a piezoelectric tire prototype.

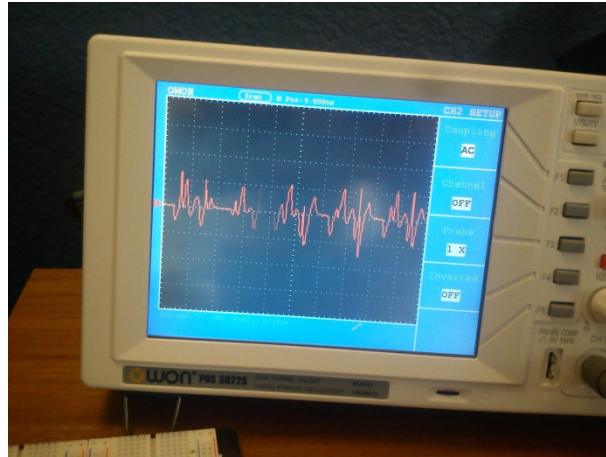

Figure 9: Owon PDS 50225 Oscilloscope



Figure 10: Cen-tech Digital Multimeter

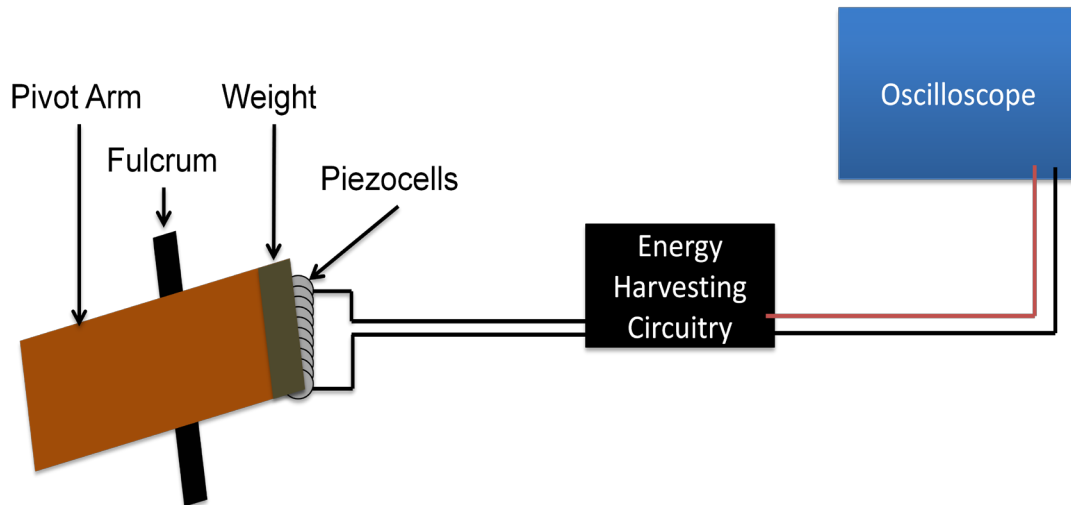

Figure 11: Initial Circuit Design Analysis Setup

Once the preliminary circuit design for the piezoelectric tire had been properly developed and analyzed, the device was fully assembled and tested. The electrolytic capacitor was first fully discharged using CBA III battery testing (figure 12 below) program to ensure that there was no energy already in the capacitor. The tire was then attached to the bicycle where it was rode for 1 mile. The supercapacitor was again analyzed using CBA III battery testing device. A second measure of the parameters was done using a secondary supercapacitor was used to ensure the results were correct.

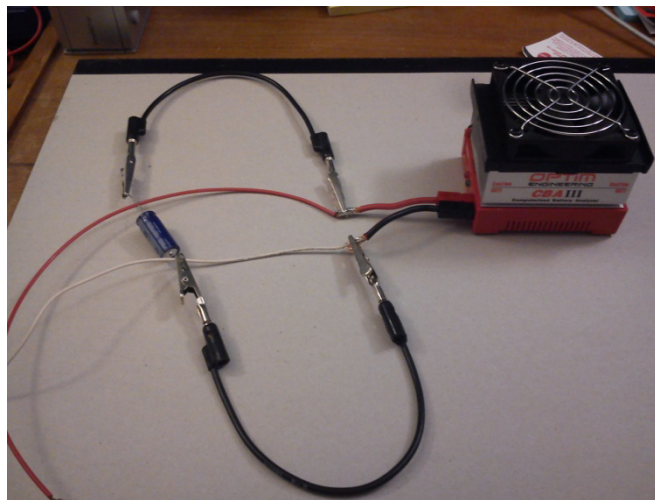

Figure 12: CBA III Battery Testing Device

Financial Analysis

Lastly a financial analysis was done to determine the economic feasibility of this technology. Using the efficiency information from the physical testing portion of the study, targets for the cost of the tire were determined. A computer model of price per product was developed to determine whether it makes financial sense to develop this technology further. The effectiveness of the tire at harvesting energy was compared to the lifecycle of the tire in order to determine financial feasibility. An expected lifetime of 1000 miles was assumed for the piezoelectric tire. The total energy output was compared to the increase cost in manufacturing. These models then use market trends for similar technologies to come up with three possible scenarios for where piezoelectric energy harvesting could go if a concerted effort was made to make it a viable option. These models take into account economies of scale and the possibility of government subsidies because these are already being used in the three technologies chosen. Analysis was done using Microsoft Excel computing software.

Physical Testing

The results of the energy harvesting of the piezoelectric tire can be shown below. The current remained around 0.5 A for the entire discharge. The voltage began at 0.11 Volts and ramped down to 0 Volts after 45 seconds. In total there was a peak power output of 5.06 mW from the capacitor and a total of 70.92 mWs.

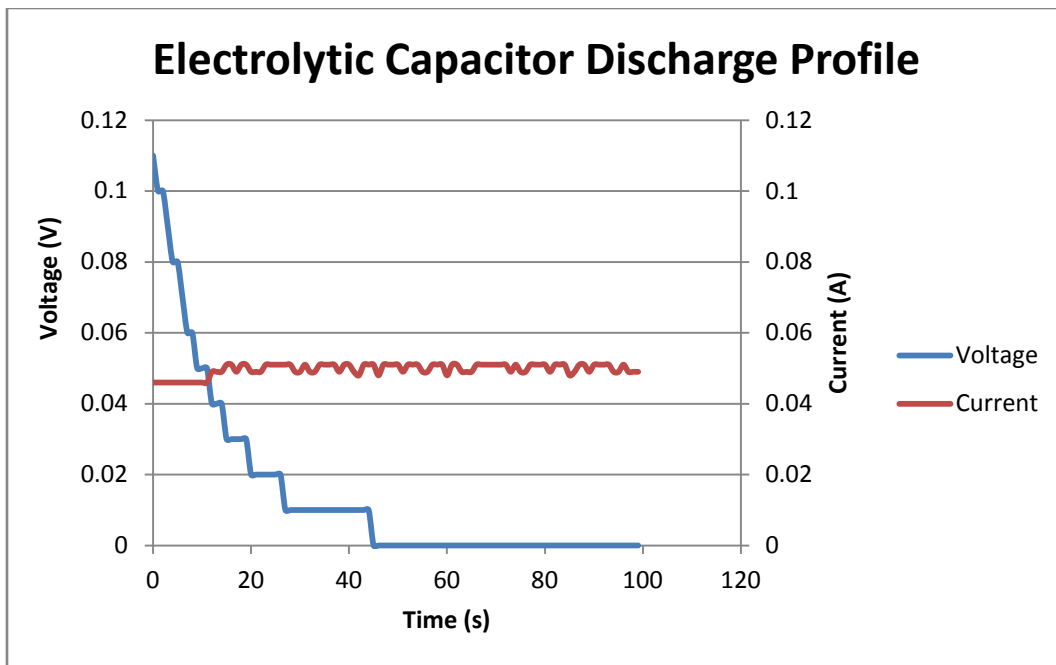

Figure 13: Discharge Profile of Supercapacitor

These power results are consistent with piezoelectric energy harvesting devices that are currently available for purchase, though total energy harvested is less than expected. To reach the comparable energy output of a AA alkaline battery, one would need 150,000 of these circuits.

Using this logic, a device that incorporated this many circuits would weight nearly 5,000 kg and would require a circumference of 1,500 meters in order to fit all of the circuits.

Financial Testing

This device cost a total of \$55.25 to make on top of the cost of the tire and rim. The piezoelements cost \$0.50 each. There were a total of 96 of them for \$48.00. The circuitry cost a total of \$4.76 in wires, a bridge rectifier, and capacitors. The electrolytic capacitor cost \$2.49.

This equates to a cost of \$55.25 for 70.92 mWs which is equivalent to \$2,804,000/Wh. This can also be calculated based on power which works out to \$10,918/W. If the tire were to survive for 1000 miles the total energy cost would work out to \$2,804/Wh and \$10,918/W

In order to help determine when this could become commercially viable a financial model was developed. There were three different historical trends that were used to develop three possible scenarios for the piezoelectric financial model: computer storage capacity (figure 14 below), solar photovoltaics (figure 15 below), and lithium ion batteries (figure 16 below).

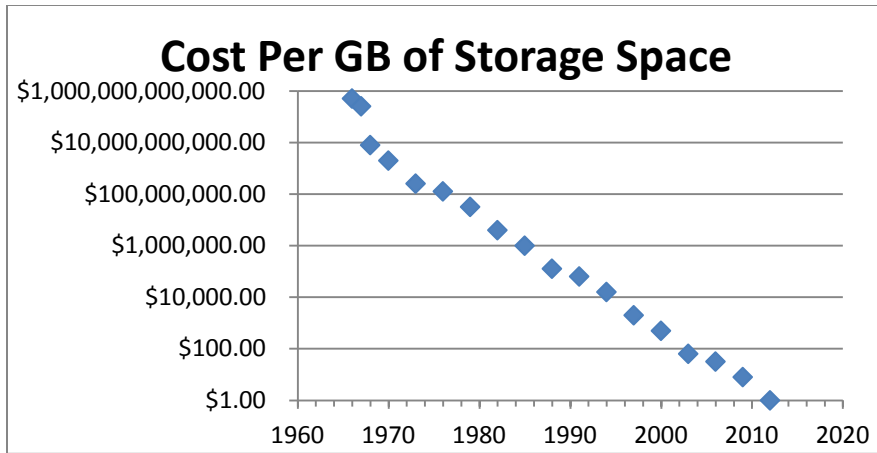

Figure 14: Cost per GB of Storage over Time [21]

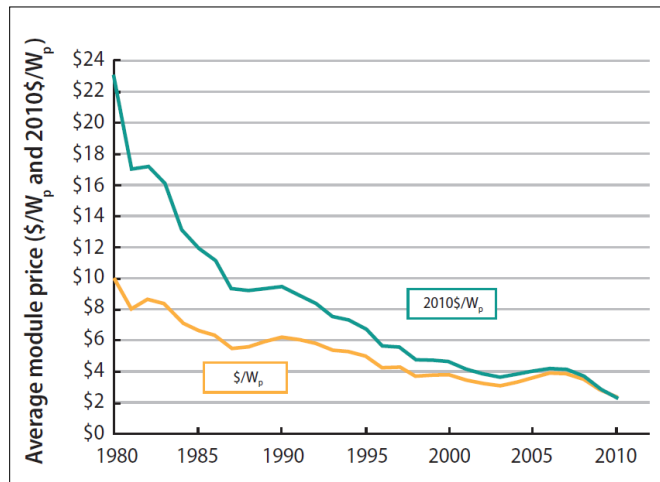

Figure 15: Cost per W of Solar Photovoltaics over Time [22]

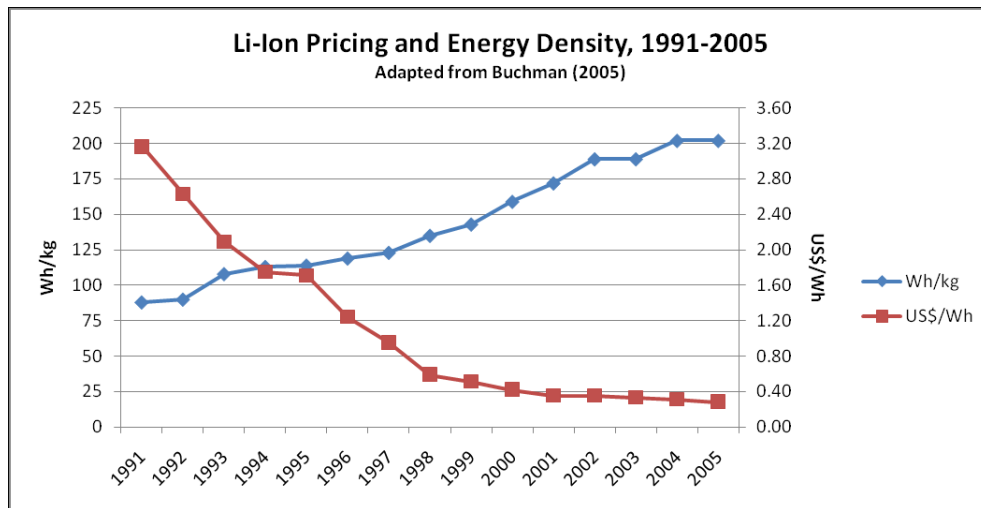

Figure 16: Cost for Li-Ion Batteries over Time [23]

Cost per watt was the starting points for the developed model. Future results were modeled using these three possible scenarios. The scenario that follows the cost of computational storage can be found in figure 17 below.

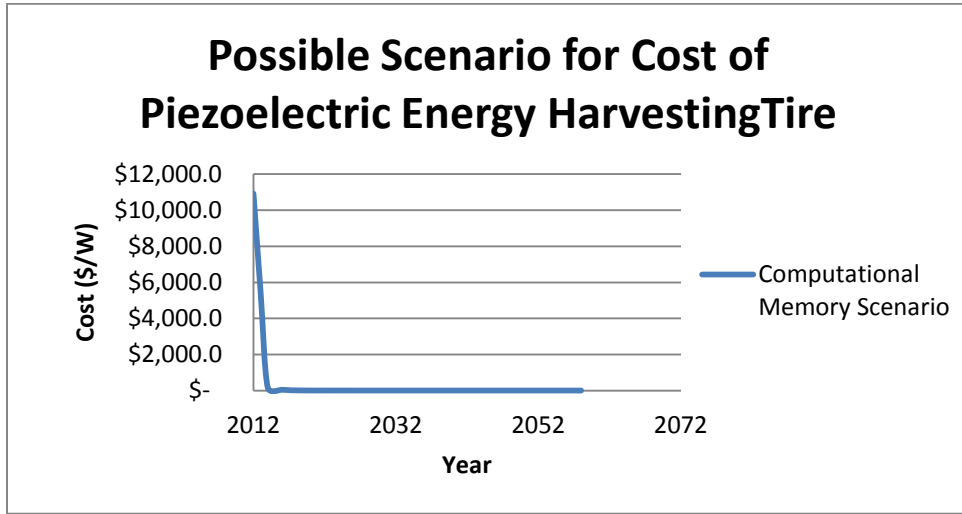

Figure 17: Possible Scenario for Cost of Piezoelectric Energy Harvesting Tire

This scenario is unlikely to occur because there was a strong demand for higher computational power, but there is not the same demand for energy harvesting devices. However, if it were to follow this trend, the product would become marketable (less than \$100/W) at around year 2014. More likely the trend will follow that of photovoltaics or lithium ion batteries (shown in figure 18 below).

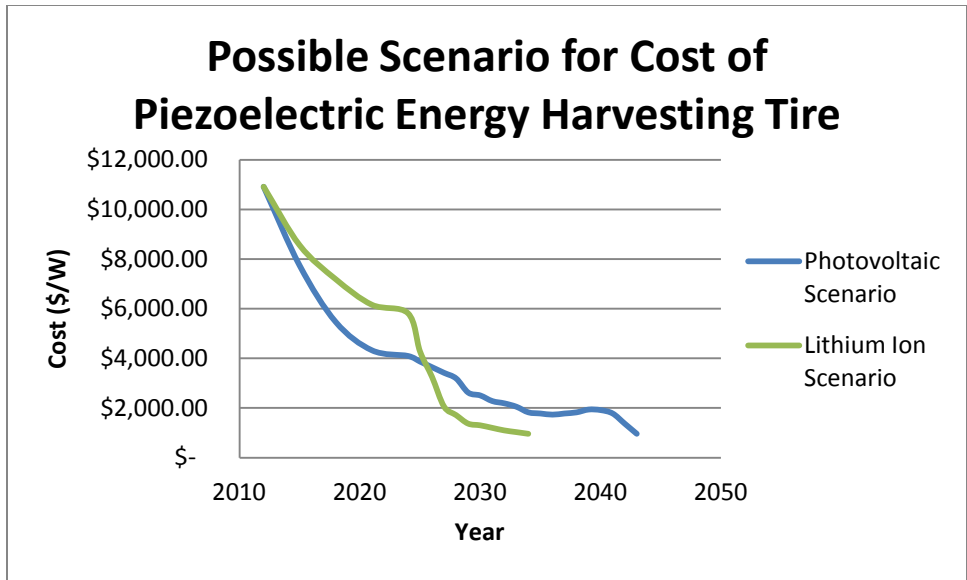

Figure 18: Possible Scenario for Cost of Piezoelectric Energy Harvesting Tire

These two scenarios show that it is unlikely for the piezoelectric energy harvesting tire to get to less than \$100/W anytime in the next 20 years. The lowest that both of these scenarios have the price getting to is \$950/W. The lithium ion scenario has it reaching this in 2035 and the photovoltaic scenario has it reaching this in 2045. Table 1 below shows the year in which each of the scenarios reach \$1000/W.

Table 1: Year When Various Scenarios Reach \$1000/W

Scenario	Year
Computational Memory	2014
Lithium Ion Battery	2026
Photovoltaic	2043

Some key things to point out are the differences in these scenarios between the drivers of the cost reduction, the breakthroughs that made it possible and the government incentives that helped motivate the market. Both the computational memory scenario and the lithium ion scenario had their main drivers as a variety of industries. They were both driven down by high demand across all business dimensions from cellular phone demand to laptop demand, all of which were used by most industries. The photovoltaic scenario was only driven by one industry, the energy industry that was content with the current model. It is likely that the piezoelectric energy harvesting tire is likely to follow the photovoltaic model because it is unlikely to be used in the vast majority of industries. These three technologies also all had major breakthroughs that made their downward trend possible. Major breakthroughs would be needed if the piezoelectric energy harvesting tire is to follow a similar trend. Additionally, the only scenario that has government incentives was the photovoltaic scenario. While that has helped to drive down the cost and build up a market over the years, a government incentive alone is unlikely to make this product marketable.

Chapter 5

CONCLUSION

There are a number of issues that must be addressed if the piezoelectric energy harvesting tire is to ever become a commercial product. This product has a number of advantages over current available technologies. Particularly this device does not require any fuel and does not have any emissions. However, the piezoelectric tire has very high costs, very low power and energy output, poor durability, and high weight. It is clear that this technology is far from commercialization. Piezoelectric energy harvesting is best served for very low power requirements in remote applications.

Advantages

The main advantage of the piezoelectric energy harvesting tire is that it captures energy that would otherwise be wasted. Additionally, this device does not require the use of any fuels to run. That means this is a renewable source of energy.

The piezoelectric tire only requires mechanical motion, allowing for the device to be used in remote areas where there is no connection to the electrical grid. This device has the potential to be used for camping or biking trips where power is needed for cell phones, lights, or radios. This device could also be used in the third world where the electrical infrastructure is not fully developed.

Piezoelectric energy harvesting also has the advantage that it does not have any emissions. Most remote energy devices require gasoline or liquefied natural gas. These devices are one of the most polluting, so zero emission

alternatives could provide major benefits to the environment and local communities.

Disadvantages

There are a whole host of disadvantages of the piezoelectric energy harvesting tire, chief among them extremely small energy production, high costs, poor durability, and high weight. The energy produced from the energy harvesting tire is too small for it to be used in the vast majority of applications. Additionally there is so little power generated by the tire that it cannot be used for anything but the minutest power applications.

The other major issue is cost. This device cost around \$50 or 50 times the cost of a traditional AA alkaline cell. If this is ever to become commercially viable it the cost will have to come down to less than \$5.

This device also has very poor durability. The piezoceramics are easily broken. The wires are very small and soldered to the piezocell. This was the biggest issue from a durability perspective. There is also the issue that these cells will consistently come in contact with the road under heavy pressure. These cells will wear down, especially if they are not properly protected or incorporated into the tire. Additionally, with the number of wires that is required for this circuit, the likelihood that one of them would become loose, disconnected, or break substantially increases and can be difficult to find.

Lastly, the circuitry for the piezoelectric tire adds a bit of weight. If one is only adding a few of these circuits the weight will not be much of an issue. However, if you add the number of circuits required to produce the same amount

of power from a AA alkaline battery, the weight at 5,000 kg would be far too much for a human to be able to move.

Chapter 6

RECOMMENDATIONS

There are likely far too many obstacles for the piezoelectric energy harvesting tire to become commercial in the near term. Unless there is a substantial change to the technology that allows it to capture more energy at a much cheaper cost, this technology will remain dormant.

For those who wish to use this technology for remote power applications, there are other technologies that could produce more energy for much less cost. One possible alternative that uses a bicycle is connecting a generator to the wheel of the bicycle.

Piezoelectric energy harvesting does have some potential to work where small amounts of energy are required and repetitive compression takes place. Further research into using piezoelectric energy harvesting in other applications could yield results that increase efficiency and cut costs. This research could help to make a future piezoelectric tire more commercially viable. In the meantime, future research should focus on other types of energy harvesting.

REFERENCES

- [1] Nobel Prize. (2011, Feb) NobelPrize.org. [Online].
http://nobelprize.org/nobel_prizes/physics/laureates/1903/pierre-curie-bio.html
- [2] S Katzir, *The Beginnings of Piezoelectricity: A Study in Mundane Physics*, 1st ed., J Renn, K Gavroglu R Cohen, Ed. Boston, USA: Springer, 2006.
- [3] Acmite Market Intelligence, *Market Report: World Piezoelectric Device Market*, 1st ed., Acmite Market Intelligence, Ed. Ratingen, Germany: Acmite Market Intelligence, 2011.
- [4] JW Prall, J Harold, and SH Schneider WRL Anderegg, "Expert Credibility in Climate Change," *Proceedings of the National Academy of Sciences of the United States of America*, vol. 107, no. 27, pp. 12107-12109, July 2010.
- [5] US Environmental Protection Agency Office of Transportation and Air Quality, "Greenhouse Gas Emission from the US Transportation Sector, 1990-2003," US Environmental Protection Agency, Fairfax, VA, Transportation GHG Emissions Report 2006.
- [6] J Eilperin, "Emissions limits, greater fuel efficiency for cars, light trucks made official," *Washington Post*, April 2010.
- [7] USA Today Staff Writer, "A Decade After First Prius, Toyota's Hybrid Sales Pass 1M," *USA Today*, June 2007.
- [8] Nithya Thambi, Mary Anne Bitetto and E.B. Hameyie Kimberly Ann Cook-Chennault, "Piezoelectric Energy Harvesting : A Green and Clean Alternative for Sustained Power Production," *Bulletin of Science Technology & Society*, pp. 496-509, 2008.
- [9] Shashank Priya, "Advances in Energy Harvesting Using Low Profile Piezoelectric Transducers," *Journal of Electroceramics*, no. 19, pp. 165-182, 2007.
- [10] Ph.D., and James Brodrick, Ph.D., Kurt Roth, "Energy Harvesting," *ASHRAE Journal*, pp. 84-86, 2008.
- [11] Christopher A Howells, "Piezoelectric Energy Harvesting," 2009.
- [12] Ryosuke Matsuzaki and Akira Todoroki, "Wireless Monitoring of

- Automobile Tires for Intelligent Tires," *Sensors*, pp. 8123-8138, 2008.
- [13] * Min-Soo Kim, Dae-Su Lee, and Jae-Sung Song Soon-Jong Jeong, "Properties of a Multi-Stack Type Piezoelectric Energy Harvesting Device," *Integrated Ferroelectrics*, pp. 208-215, 2008.
- [14] Daisuke Koyama and Kentaro Nakamura, "Array Configurations for Higher Power Generation in Piezoelectric Energy Harvesting," *Japanese Journal of Applied Physics*, pp. 1-5, 2010.
- [15] Dongna Shen, "Piezoelectric Energy Harvesting Devices For Low Frequency Vibrations," *Auburn University*, pp. 1-196, 2009.
- [16] Daniel J. Inman and Gyuhae Park Henry A. Sodano, "Comparison of Piezoelectric Energy Harvesting Devices for Recharging Batteries," *Journal of Intelligent Material Systems and Structures*, pp. 799-804, 2005.
- [17] D. GUYOMAR, E. LEFEUVRE AND C. RICHARD A. BADEL, "Efficiency Enhancement of a Piezoelectric Energy Harvesting Device in Pulsed Operation by Synchronous Charge Inversion," *Journal of Intelligent Material Systems and Structures*, pp. 889-901, 2005.
- [18] Guan Mingjie, "Characteristics of Piezoelectric Energy Harvesting Circuits and Storage Devices," *The Chines University of Hong Kong*, pp. 1-143, 2006.
- [19] Martin L. Dunn and Kurt Maute Cory J. Rupp, "Analysis of Piezoelectric Energy Harvesting Systems with Non-linear Circuits Using the Harmonic Balance," *Journal of Intelligent Material Systems and Structures*, pp. 1383-1396, 2010.
- [20] Y C Shu and I C Lien, "Analysis of Power Output for Piezoelectric Energy Harvesting Systems," *SMART MATERIALS AND STRUCTURES*, pp. 1499-1512, 2006.
- [21] Steve Gilheany, "Cost of Semiconductor Ram Over 50 Years," *Archive Builders*, 2012.
- [22] US Department of Energy, "2010 Solar Technologies Market Report," *Department of Energy*, Golden, CO, 2010.
- [23] David L Anderson, "An Evaluation of Current and Future Costs For Lithium-Ion Batteries For Use in Electrified Vehicle Powertrains," *Duke*

University, 2009.

- [24] Piezo Systems Inc. (2012, Nov.) Piezoelectric Energy Harvesting Kit. [Online]. <http://www.piezo.com/prodproto4EHkit.html>
- [25] Piezo Systems, Inc. (2012, Nov.) Standard Brass Reinforced Extension Generators. [Online]. www.piezo.com/prodexg1brass.html
- [26] Mide. (2012, November) Vibration Energy Harvesting Products. [Online]. http://www.mide.com/products/volture/volture_catalog.php
- [27] Arveni. (2012, November) Standard 50 Hz Energy Harvester. [Online]. http://www.arveni.fr/attachments/article/33/DATASHEET_Vibration_Energy_Harvester_50Hz_AV50s.pdf
- [28] Arveni. (2012, November) Standard Pulse Energy Harvester: AR01. [Online]. http://www.arveni.fr/attachments/article/33/DATASHEET_Pulse_Energy_Harvester_AR01.pdf
- [29] Linear Technology. (2012, November) LTC3588-1 - Piezoelectric Energy Harvesting Power Supply. [Online]. <http://www.linear.com/product/LTC3588-1>
- [30] Harry Igbenehi, "Piezoelectric Energy Harvesting 2013-2023: Forecasts, technologies, Players," ID Tech, Market Research Report 2012.
- [31] Jim Beal. (2011, October) Electricity from the Nose: Engineers Make Power from Human Respiration. [Online]. <http://www.engr.wisc.edu/news/archive/2011/Oct11.html>
- [32] N M White, P Glynne-Jones, and S P Beeby, "A Novel Thick-Film Piezoelectric Micro Generator," *Smart Materials and Structures*, no. 10, pp. 850-852, August 2001.
- [33] Science Daily. (2012, January) Graphene's Piezoelectric Promis. [Online]. <http://www.sciencedaily.com/releases/2012/01/120105145837.htm>
- [34] Chen Xu, Xudong Wang, and Zhong Lin Wang, "'Nanowire Structured Hybrid Cell for Concurrently Scavenging Solar and Mechanical Energies'," *Journal of the American Chemical Society*, vol. 131, no. 16, pp. 5866-5872, April 2009.

APPENDIX I

CURRENT STATE OF THE MARKET AND FUTURE OUTLOOK

Current State of the Market

Piezoelectric energy harvesters are currently being sold for a number of applications, but are exclusively for low power and energy required devices. These applications include remote sensors, remote controls, self winding watches, doorbell sensors. Currently, the main usage of piezoelectric energy harvesters is in cigarette lighters and push starts for propane lighters.

Piezoelectric energy harvesting kits are now also currently available for purchase from several companies. One of these kits is available from Piezo Systems Inc. of Woburn, MA [24]. This kit consists of a Double Quick-Mount Harvesting Bender that contains the piezoelements and a piezo energy harvesting circuit that contains a capacitor bank that is discharged when fully charged. The kit has a weight of 10.4 g, open circuit voltage of 20.9 V, and peak output power of 7.1 mW. The kit is 2" x 0.55" x 0.7" and costs \$600 for a single kit or \$317/kit if you purchase 100 or more kits.

Piezo Systems Inc. also has a number of piezo energy harvesting generators. The generator with the highest output power is the T226-H4-503Y [25], with a peak power output of 2.0 W at 2000 Hz. The generator is 1.25" x 2.5" , weighs 10.3 g and ranges in cost from \$165 to \$75/generator depending on the quantity purchased. While this may seem like an excellent option for energy harvesting, it requires a very high frequency to get the 2 W output. Lower frequencies would lower the output power quite substantially.

Another company that produces piezoelectric energy harvesting kits is Mide. Mide produces a line of Vulture energy harvesting products that include energy harvesters, hybrid solar/piezo energy harvesters, and energy harvesting electronics [26]. The energy harvesting systems can produce up to 9 mW of power with 50 Hz frequency for a cost of \$399. The energy harvesters range in price from \$50 to \$87.50 and operate in a range of 26-245 Hz with a peak power output of 9 mW. Lastly the energy harvesting circuitry costs between \$35 and \$87.50 depending on the desired complexity of the circuitry.

Arveni is another company that produces energy harvesting kits. The AV50s Vibration Energy Harvester has a peak energy output of 200 mW at 50 Hz [27]. The device weighs 120 g and has dimensions of 4 cm x 4 cm x 14.5 cm. While this device can produce a decent amount of energy at 50 Hz, it falls off substantially at different frequencies. For instance, power output drops to 13 mW when just 3 Hz away from the optimal frequency (47 Hz & 53 Hz). Additionally, Arveni has an AR01 Standard Pulse Energy Harvester [28]. For every 2 N of force, this device produces 0.25 mWh of energy. This device has dimensions of 1.5 cm x 1.0 cm x 6.2 cm and has a life of over 1,000,000 cycles according to Arveni. These devices do not have prices as they are in the early commercialization phase of production.

Linear Technologies is a company that is focused on energy harvesting circuitry. Their LTC3588-1 Piezoelectric Energy Harvesting Circuit is designed to output 200 mW with high efficiency [29]. Their energy harvesting circuits vary

depending on specifications, but all work with very low power inputs converting with high efficiency with a cost between \$3.50 and \$4.96.

Future Outlook

With the number of applications of piezoelectric energy harvesting growing constantly, the market is expected to grow over the next ten years. According to a recent IDTech report, the piezoelectric energy harvesting market is likely to reach \$145 million by 2016 and \$667 million by 2022 [30].

There are a number of applications for energy harvesting that are in the initial development stages, but could yield results that would help make piezoelectric energy harvesting tires more feasible. These include using piezoelectric energy harvesting in the human body, shoes and clothing, pavement, roads, railroads, toys and gadgets, aerospace, and sensors.

Researchers Shi and Wang at the University of Wisconsin-Madison have invented a device that uses advanced piezoelectric materials to harness energy from vibrations to the mouth caused by breath [31]. Other research using piezoelectric energy harvesting in the body include harnessing energy from leg motion, respiration, heartbeats, and blood pressure. This energy, while small, could be used to monitor blood glucose levels or help make a pacemaker battery last longer.

Energy harvesting in shoes and clothing, pavement, aerospace and sensors was already discussed in the literature review section, but each of these applications could help to bring advances to the entire piezoelectric energy harvesting field.

There are number of technological changes that could also help make piezoelectric energy harvesting more economical. These are mostly broken up into three groups: the development of advanced piezo materials, frequency optimization techniques, and hybrid energy generators. Each of these technological changes could substantially change the amount of energy that can be harnessed using piezoelectric materials.

Currently the most common material for piezoelectric energy harvesting is lead zirconate titanate (PZT). However there are over 200 piezoelectric materials that have been found to have piezo effects. One example is organic polyvinylidene difluoride (PVDF), which is flexible, light weight, inexpensive, and chemically inert [30]. Another possible type of material is soft piezoceramics. These materials are good for energy harvesting in that they have high piezoelectric charge coefficients and high coupling factors, but have the major disadvantage of poor durability. A similar technology has been proposed by White, Glynn-Jones and Beeby uses thick-film piezoelectric coatings to increase the piezoelectric charge coefficients [32]. Graphene is another possible option for piezoelectric energy harvesting [33]. This material helps to increase the durability and cost of piezoelectric. Work by material scientists to generate piezoceramics that can withstand constant impact while greatly increase the efficiency of piezoelectric energy harvesting, could help improve the feasibility of piezoelectric energy harvesting tires.

Another advancement that would help make piezoelectric energy harvesting tires more feasible in the future is frequency tuning devices. This has

been shown to increase power by up to 20 times [30]. For example, piezoceramics that have a peak energy output around between 0.5 Hz and 5.0 Hz would drastically increase the energy output of an energy harvesting tire. This is due to the fact that bicycle tires usually rotate at a rate of 0.5-5.0 Hz. Another possible option is the use of other devices that are able to tune the piezoelectric generator to work at that frequency. This could be done through mechanical frequency adjusters that use a gearing mechanism. Another possible option would be to pre-bias the material by adding a charge to the material. This requires more work to be done to the piezoceramic, but could be useful in situations where significant forces are felt, such as bicycle tires.

Lastly, piezoelectric energy harvesting can be paired with other forms of energy generation to help make the system as a whole more efficient. Xu, Wang, & Wang have developed a method for harnessing solar energy and mechanical energy in the same nanowire structure [34]. This device could work simultaneously to increase the generation, which would help further promote remote energy harvesting applications.

While piezoelectric energy harvesting is currently limited to low power, low energy applications, advances in technology and application could help to significantly change the energy output. Further research into these other applications could eventually help to make a piezoelectric energy harvesting tire become commercially feasible.