

Moving Towards Sustainable and Resilient Smart Water Grids:  
Networked Sensing and Control Devices in the Urban Water System

by

Michele Mutchek

A Thesis Presented in Partial Fulfillment  
of the Requirements for the Degree  
Master of Science

Approved October 2012 by the  
Graduate Supervisory Committee:

Braden Allenby, Chair  
Eric Williams  
Paul Westerhoff

ARIZONA STATE UNIVERSITY

December 2012

## ABSTRACT

Urban water systems face sustainability challenges ranging from water quality, leaks, over-use, energy consumption, and long-term supply concerns. Resiliency challenges include the capacity to respond to drought, managing pipe deterioration, responding to natural disasters, and preventing terrorism. One strategy to enhance sustainability and resiliency is the development and adoption of smart water grids. A smart water grid incorporates networked monitoring and control devices into its structure, which provides diverse, real-time information about the system, as well as enhanced control. Data provide input for modeling and analysis, which informs control decisions, allowing for improvement in sustainability and resiliency. While smart water grids hold much potential, there are also potential tradeoffs and adoption challenges. More publicly available cost-benefit analyses are needed, as well as system-level research and application, rather than the current focus on individual technologies. This thesis seeks to fill one of these gaps by analyzing the cost and environmental benefits of smart irrigation controllers. Smart irrigation controllers can save water by adapting watering schedules to climate and soil conditions. The potential benefit of smart irrigation controllers is particularly high in southwestern U.S. states, where the arid climate makes water scarcer and increases watering needs of landscapes. To inform the technology development process, a design for environment (DfE) method was developed, which overlays economic and environmental performance parameters under different operating conditions. This method is applied to characterize design goals for controller price and water savings that smart

irrigation controllers must meet to yield life cycle carbon dioxide reductions and economic savings in southwestern U.S. states, accounting for regional variability in electricity and water prices and carbon overhead. Results from applying the model to smart irrigation controllers in the Southwest suggest that some areas are significantly easier to design for.

## ACKNOWLEDGMENTS

This research was supported, in part, by the grant “Sustainable infrastructures for energy and water supply” (#0836046) from the National Science Foundation, Division of Emerging Frontiers in Research and Innovation (EFRI), Resilient and Sustainable Infrastructures (RESIN) program. Thanks also go to Eric Willams, Jeanne Jensen, Morteza Abbaszadegan, Brad Allenby, Tom Roberts, Jim Holway, Sara Hughes, David McNeil, Paul Westerhoff, the Center for Earth Systems Engineering and Management, The Sustainability Consortium, the Journal of Industrial Ecology, and anonymous reviewers.

## TABLE OF CONTENTS

CHAPTER	Page
1 INTRODUCTION.....	1
2 SMART WATER GRID OVERVIEW AND ANALYSIS.....	4
Smart Water Grid Background .....	4
Sustainability, Resiliency, and Smart Water Grid.....	12
Smart Water Grid Adoption .....	35
The Future of Smart Water Grid .....	46
3 DESIGN SPACE CHARACTERIZATION FOR MEETING COST AND CARBON REDUCTION GOALS: SMART IRRIGATION CONTROLLERS IN THE SOUTHWESTERN UNITED STATES .....	48
Introduction.....	48
Design for Environment Method: Meeting Multiple Performance Goals under Variable Operating Conditions .	57
Case Study of Design Constraints to Realize Life Cycle Economic and Carbon Dioxide Reduction Benefits .....	62
Implications .....	87
4 CONCLUSION .....	89
NOTES .....	92
REFERENCES .....	93
APPENDIX	
PERMISSION FOR CO-AUTORED WORKS .....	105

## Chapter 1

### INTRODUCTION

Modern infrastructure – including urban water grids – face sustainability and resiliency challenges. Changes in climate and population are making water supplies scarcer in some areas (Day and Conway 2009; Gertner 2007; Hunaidi et al. 2005). Water systems are inefficient, wasting a percentage of treated water in both the distribution system and at the end-use location, mainly through leaks (Mayer and DeOreo 1999; McKinnon 2007). In many places, such as the Southwest United States., water must be conveyed over long distances to water treatment plants, resulting in the use of significant amounts of energy for pumping (Cohen 2004). Maintaining water quality also remains a challenge in the distribution system, where contaminant intrusion and biofilms reduce water quality (Karim et al. 2003; Hall-Stoodly and Stoodly 2005). Problems with end-user plumbing can then further decrease water quality. The water distribution system is also vulnerable to targeted attacks through water poisoning, as well as catastrophic main breaks due to undetected pipe deterioration (Hunaidi et al. 2005; U.S. Environmental Protection Agency 2009).

Technological revolutions such as electricity and the combustion engine transform economies and societies, including supporting infrastructures supplying water, energy, and mobility. Information and communication technology (ICT) is the dominant technological revolution for several decades. In addition to economic and social effects, ICTs also drive changes in drivers of environmental

issues and add to the portfolio of potential solutions (Williams 2011). The benefits of ICTs can presumably be enhanced through intentional adoption for sustainability purposes.

Compared to manufacturing and service sectors, adoption of ICTs in infrastructures is relatively slow, presumably due to longer time scales involved. There has been progress in the last decade in the development of the smart electrical grid. Smart electric meters and other two-way communication devices have been installed in many places to allow electric utilities to track electrical usage in real-time. This allows utilities to make continual adjustments to the system. Whether responding to a power transformer failure or trying to help shift electrical usage to off-peak time, the hope is that smart electrical grid will make power generation and delivery more efficient and resilient and less costly, while reducing total energy use (U.S. Department of Energy n.d.).

ICTs could be integrated into water systems to yield a smart water grid analogous to the smart electrical grid. As yet however, there is little concerted effort to analyze and promote a smart water grid. In the literature, there are several efforts to develop and analyze components of a smart water grid. Some of the literature focuses on the benefits of specific technologies such as smart pumps (Brzozowski 2010). Other research takes a step further and analyzes the implementation of specific smart technology systems, such as automated meter reading (AMR) and advanced metering infrastructure (AMI) for water infrastructure, which are systems that use smart water meters for residential and commercial water consumption billing (Kenna 2008; Badger Meter Inc. 2010).

However, there exists little integrative, strategic, and macro-level discussion of smart water grid in the academic or other literature.

Chapter 2 of this thesis begins to fill this gap by presenting a vision of how smart technologies could be implemented at several scales and combined to contribute to more sustainable and resilient water systems. Additionally, this thesis seeks to outline the challenges to smart water grid realization, acknowledge the potential disadvantages of the smart water grid, and suggest future areas of work and research. For this initial work, this thesis focuses on drinking water distribution in an urban environment. Future work beyond the scope of this thesis should expand to include more environments and other parts of the water cycle. For example, agriculture is an important part of a complete smart water grid vision given its high share of water use.

One of the future areas of work for smart water grid is the further development of new technologies as well as the creation of publically available cost-benefit analyses. Chapter 3 of this thesis seeks to fill this gap by analyzing residential smart irrigation controllers in the Southwest. A number of studies have tested the ability of smart irrigation controllers to save water in residential and small commercial settings. Results generally show overall savings, but there is substantial variability, including cases of increased water use. Though there are many controllers on the market, there is a further need for optimization of design and field performance. Chapter 3, therefore, introduces a design for environment (DfE) method that analyzes the economic and environmental performance of smart irrigation controllers in order to inform future design.



## Chapter 2

### SMART WATER GRID OVERVIEW AND ANALYSIS

#### **Smart Water Grid Background**

##### *Methodology, Goal, and Scope*

This chapter consists of a qualitative review and assessment of smart water grid. A variety of sources were used including peer reviewed literature, conference presentations, web pages, and informal interviews with experts. This chapter summarizes the findings from these sources and uses what was learned to present a critical review and vision for the future of smart water grid. The scope of this assessment focuses on urban drinking water systems.

##### *Example Grid and Technical Components*

A simplified schematic of a smart water grid appears in figure 1, which also includes district metering areas (DMAs), which makes the use of smart technologies more efficient. DMAs separate the water grid into different areas like a tree, with each branch being its own separately metered end-use area, not connected to the rest of the grid, until it reconnects with the sewer pipes. Also included is a communications center, where the data collection and processing could occur in a centralized version of a smart water grid. A decentralized version of a smart water grid would have more locations for data collection and analysis.

In the remainder of this section, some of the component technologies in this vision are described.

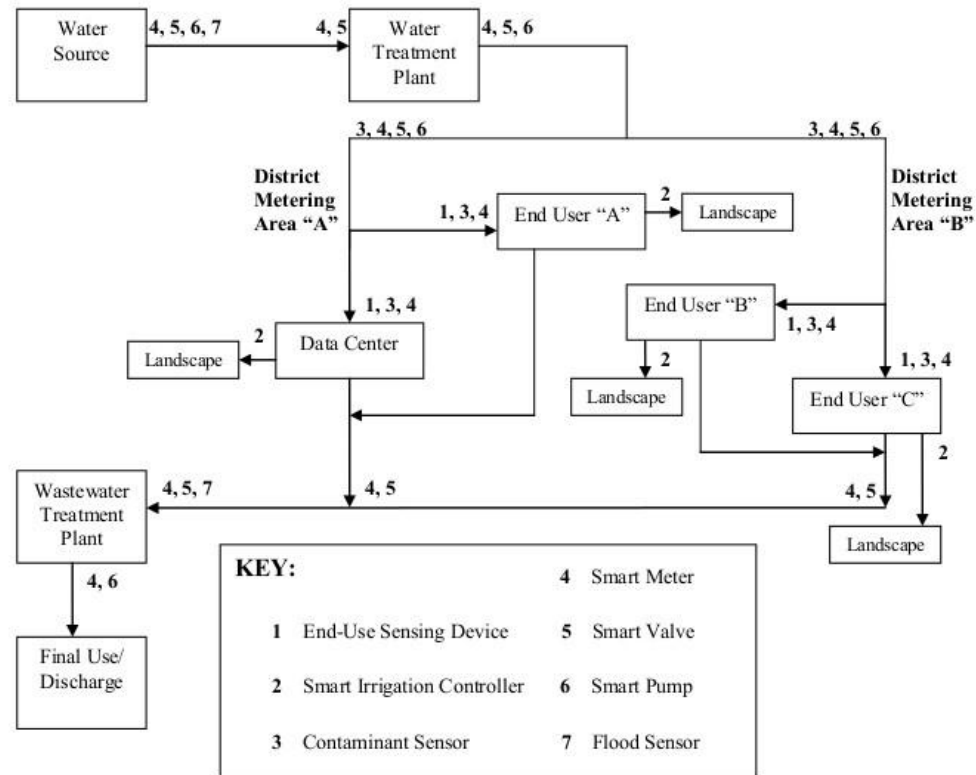

**Figure 1** Simplified diagram of an example urban smart water grid. This chapter focuses on water distribution and end-use.

## Sensing Devices

Sensing devices or sensors that collect and transmit data about the water system on a real-time basis is the foundation of any smart water grid. At the municipal level, the most common way to monitor the water delivery system has been to manually read flow and pressure meters, while water quality is commonly monitored by collecting water samples from various locations in the system that are then analyzed in a laboratory environment. In a smart water grid system, flow, pressure and quality data could be collected, stored, and transmitted to a computer by the meter itself, or by installing a contaminant sensor to detect common pathogens, water pollutants, or water quality indicators.

Smart sensors for municipalities include smart water meters for flow, smart water meters for pressure, and contaminant sensors and biosensors for contamination detection (Maier et al. 2009; Vaseashta 2011). The use of smart sensing devices increases the time resolution and resolution of information about the system. Smart sensing devices can also reduce labor costs associated with meter reading or sample collection. For example, residential smart water meters eliminate the need for someone to read each household meter for billing.

Smart water meters have additional advantages over manual meters. One of these advantages is increased sensitivity to low water flows, which increases accuracy. Other advantages of these more sensitive meters include the ability to measure backflow, which can indicate a problem in the system. They are also less susceptible to corrosion from particles in the system (Engle 2010).

Whether in a residential, commercial or industrial setting, the typical situation for water use detection is a single flow meter measuring total water consumption of a facility. How total water consumption breaks down for different uses is generally not measured. Only measuring total flow has two disadvantages: leaks are difficult to detect by metering and users lack information on potential inefficiencies in the system. One option is to install additional meters within a facility. With current technology, installing meters for every fixture would be prohibitively expensive for most end-users.

An alternative to installing additional flow meters is to use a device that measure pressure waves. Each fixture has a pressure signature that propagates through the piping system, and a sensitive pressure-gauge can distinguish between these signatures. The HydroSense technology developed by Jon Froehlich and others (2009) needs only one sensor to determine the disaggregated use of all fixtures (e.g., faucets, toilets, and dishwasher) in a single family home. If a fixture starts to leak, the end-use sensing device will pick up this flow as noise in the system. For larger end-users, multiple smart meters and end-use sensing devices would be more appropriate. The key point is that a combined flow meter and pressure sensor system requires fewer devices, substantially reducing costs.

Another interesting technology comes from the UrbanFlood project. This European project consists of a sensor network that detects strain on and early flooding over flood embankments. This type of early detection results in a rapid response that can prevent or decrease the severity of catastrophic flood events (UrbanFlood n.d.).

## System Control Devices

Smart valves and pumps adjust their operations based on environmental conditions or signals from sensors. These adjustments can happen automatically or remotely by a human controller. The main benefit of smart controllers is increased efficiency. For example, variable speed pumps sense water conditions and will ramp up or down depending on those conditions. These pumps can also be equipped to sense clogs in the system and respond by breaking up clogs and/or reversing the flow. This is especially useful for wastewater and raw water conveyance. One smart pump manufacturer estimates up to 70% cost savings over the life cycle of the pump (Brzozowski 2010). Smart valves adjust or block the flow of water in pipes based on environmental conditions. They can be used as part of pressure management strategies, as a part of leak detection activities, or to prevent environmental contamination due to combined sewer overflows (Ruggaber et al. 2007; Mistry n.d.).

At the end-use level, smart irrigation controllers show promise in helping to save water wasted on landscape irrigation. Smart irrigation controllers can receive and/or collect weather data or sense soil moisture levels, as well as other parameters, which helps determine proper water scheduling. Using this information, the watering schedule can be updated automatically on a daily basis. The valves and pumps that implement the actual watering of the landscape will then turn on and off at best times possible. Overall, smart irrigation controllers save water in the Western United States, but on an individual basis, may result in increased water use when the end-user was actually under-watering their

landscape previously (Metropolitan Water District of Southern California 2009; Devitt et al. 2008). Currently, smart irrigation controllers are not economically profitable for most homeowners, even in the arid West. There are, however, many areas in the United States where the investment in smart irrigation controllers would become profitable given modest improvements in design and reduction in prices (Mutchek and Williams 2010).

### Data and Power

Data that is collected by a sensor and stored in its data logger will need to be transmitted to a computing location. Direct line transmission via hardline has the advantage of high bandwidth, but installation costs are prohibitive for networks beyond the facility level. This means that if a utility is collecting data from residential smart meters, it is not generally feasible for the utility to either (1) tap into the homeowner(s)' internet connection, or (2) install a hardline internet connection to connect to all the meters to a utility facility.

These jurisdictional and technical issues make wireless data transmission a key approach in many cases. Even in the case of site owned and operated devices, wireless transmission can make sense. For example, a smart irrigation controller owned by a homeowner, could potentially be connected directly to the homeowner(s)' modem, but many smart irrigation controller companies use wireless communication instead, for the technical ease. Wireless protocols that could be useful to a smart water grid include mobile broadband (cellular towers), wireless broadband (Wi-Fi), personal area networks (device-to-device transmission), and satellite communication. The regularity in spacing of water

meters suggest that a mesh network design, in which each device is a communication hub for neighboring devices, is a promising approach (Khalifa et al. 2011). Another promising technology is able to broadcast a signal up to 45 miles and designed specifically for smart meter communication (Simonite 2011).

Another issue that comes up with wired or wireless communication is the powering of devices. Again, direct connection to the power grid is feasible within a facility, but for devices for the distribution system, off-grid power may be needed. This means that the power needed by the device to use a particular wireless technology/protocol will be an issue, along with the frequency of data collection and transmission by the device. Current off-grid power solutions include solar panels, water turbines, and long-life batteries (Britton et al. 2008; Engle 2010; Kenna 2008; Toto n.d.). The wireless communication protocol that transmits 45 miles has the advantage of low-power usage (Simonite, 2011). It is also worth noting that compatible computer hardware and software will be needed for whoever wants to store, view, and analyze smart water grid data.

### *Adoption Status*

Many cities have begun to install smart water technologies, with automated meter reading (AMR) and advanced metering infrastructure (AMI) probably being the most popular smart water grid pieces to be implemented, but not many have begun to plan and implement a comprehensive smart water grid. Two cities that are at least partially on the way to smart water grid are Singapore and East Bay, California.



In Singapore, massive research and development funding has led to many smart water grid projects including the development of a laser-based contaminant sensor and a smart water grid in the Singapore business district. The smart water grid in the business district tracks pressure, flow, and disinfectant levels in the distribution system. This data is transmitted via Singapore's cell network to a computer center. At the computer center, modeling software is used on the data to locate problems in the water distribution system. Problems can be pinpointed to within 40 meters and when problems are found, an alarm is sent out to the utility (PUB 2011a; PUB 2012b; PUB 2102c). Singapore has a multistage plan for implementing smart water grid in its city (Weng and Lim 2012).

East Bay Municipal Utility District (EBMUD) is the drinking water and wastewater utility for the East Bay, California, which is a region in the San Francisco Bay Area. EBMUD has several progressive programs including advanced leak detection device testing and deployment, smart irrigation controller rebates for consumers, and smart metering in conjunction with web-based tools for users. The web-based tools help consumers detect leaks on their property (Harris 2010a; Harris 2010b; East Bay Municipal Utility District n.d.).

## **Sustainability, Resiliency, and Smart Water Grid**

### *Definitions of Sustainability and Resiliency for Urban Water Systems*

Sustainable urban water systems sustain human life and health, use renewable and conflict-free water sources, and do not deteriorate ecosystems where water is taken from or disposed of by humans (Gleick et al. 1995; Gleick 1998). Urban water systems can also contribute to sustainability when they use water and energy efficiently. Resilient urban water systems continue to function and/or recover quickly from shocks such as natural disasters or system failures. This means that drinking water and sewer service continues or these services are brought back up quickly. Also, flooding and pollution is prevented or controlled (Bruneau et al. 2003). Resilient urban water systems also have the ability to prevent some disaster from happening in the first place.

#### Sustainable Water Systems

Sustainability in reference to water systems has been defined by Gleick et al. (1995) as “the use of water that supports the ability of human society to endure and flourish into the indefinite future without undermining the integrity of the hydrological cycle or the ecological systems that depend on it.” Further, Gleick (1998) puts forth criteria for sustainable water systems including

- (1) sustenance of human life and health,
- (2) maintenance of ecosystems,
- (3) meeting of local water quality standards,
- (4) continuation of water resource renewability,
- (5) existence and availability of water resource data,

(6) prevention and resolution of water conflicts, and

(7) democratic planning and decision making with participation of all stakeholders.

Water use moves towards unsustainability when water stocks and/or flows decrease in space and/or time, and when demand of water supplies increase in space and/or time. The causes of these two trends can be both anthropogenic and non-anthropogenic in nature. Water supply and demand is affected by changes in climate, population, contamination levels, culture, and technology.

Meeting the seven criteria above are still issues to some degree in many urban areas, with different areas having more or less of these issues to deal with than other urban areas. In the United States, most effort in the recent past has focused on efficient water use, improving water quality, ensuring safe discharge into the environment, and planning for future supplies and drought. Typical strategies for improving water efficiency include technological developments in low-flow fixtures and water saving devices and the use of gray water, storm water, and reclaimed water. U.S. water quality standards have also become stricter in recent years, in the hopes of reducing illness from pathogens, and reducing long-term harm caused by non-biological constituents.

In the past several years, the increased recognition of the energy-water nexus has become important, resulting in the sustainable water being linked to sustainable energy. This has resulted in water providers being more concerned with how much energy they use and energy providers being concerned with how

much water they use. For water systems, energy savings can come from restraining water losses in the drinking water distribution system and the installation of a reclaimed water distribution system, often called “purple pipes”, to deliver reclaimed water for non-drinking water uses. At the same time, increasing water quality standards can have an increased impact on energy use, because some new technologies that further improve water quality also use more energy than older technology. On the consumer side, there is a concern about how much energy traditional water heaters use, because they keep water heated 24 hours a day, regardless of whether or not hot water is needed at the moment (Collins 2010).

### Resilient Water Systems

Resiliency, like sustainability, is a term with a historical dictionary definition but is emerging as a construct to understand and manage complex systems. As with sustainability, there are different ideas about what resiliency means and consensus regarding its meaning is less developed. One line of use of the term is linked with evolution of complex systems. “Resilience provides the capacity to absorb shocks while maintaining function. When change occurs, resilience provides the components for renewal and reorganization” (The Environmental Advisory Council to the Swedish Government 2002). The framing of resiliency ranges from a generic property in systems theory (Holling 2001) to quantitative modeling of adaptability in response to a set of defined shocks (Conrad et al. 2006). The approach here is to focus on a set of important shocks to

water systems and qualitatively discuss the role of smart water grids in increasing adaptability to these shocks.

In the context of infrastructure and urban systems, resiliency refers to the ability of the system to maintain its functionality, even when the system is under stress and/or some sort of disaster hits. Bruneau and collaborators (2003) build out resiliency in the context of engineering urban systems, identifying four aspects: robustness, redundancy, resourcefulness and rapidity. For water systems specifically, this means the prevention of flooding, the continuation of clean water delivery, as well as the continuation of sanitary sewer services. Alternatively, resiliency can be defined in a way that allows for a loss of functionality, but only temporarily. This means that the system must be brought back to a functioning state in a reasonable time period in order to be considered resilient.

The causative agents that undermine the resiliency of water grids can be separated into two categories: stressors and threats. Stressors make the system weak and include things like climate change, changes in population or water usage, changes in water availability, infrastructure breakdown, regulatory changes, financial changes, land use changes, and pollution. Threats, on the other hand, are infrequent natural or man-made disasters that significantly test the resiliency of the system in a short period of time. These include things like earthquakes, storms, terrorist attacks, accidents, and intentional tampering. Water systems that are weakened by stressors will be much more likely to fail when disasters hit (Hunaidi et al. 2005; Milman and Short 2008).

In addition to stressors and threats, there is the issue of the interconnectedness of infrastructure systems during disasters. For example, in New York, the collapse of the World Trade Center ruptured water mains. These mains flooded uncontrolled for an extended period of time. One result of this was reduced pressure in the water system, making it impossible for fire fighters to utilize this water source fully. Luckily, firefighters could utilize water in the Hudson River to put out the fires. The other result was the flooding of part of a telecommunications system, which had global effects (O'Rourke 2007).

This interconnectedness of systems, stressors, and threats indicate that a systems approach may be appropriate when attempting to improve the resiliency of water systems. Fiskel (2003) argues that engineered systems cannot be designed to anticipate all possible stressors or threats, but they can be imbued with characteristics that foster adaptability, self-organization, and robustness in the face of unexpected stressors and threats. Fiskel advocates the idea of distributed systems that are independent, yet interactive. Threats acting on a distributed system will generally only destroy part of the system rather than the entire system, whereas in a centralized system, the entire system may be destroyed. Types of systems that can be distributed include water, power, computing, and workforce.

### *Sustainability Issues in Urban Water Systems*

#### Water Losses

A water loss is unaccounted-for water, which is the difference between water entering and water being utilized in the system. Losses occur from leaks, unmetered consumption (legal or illegal), and meter inaccuracies (Kenna 2008). A multi-city study done by Mayer and DeOreo (1999) found that 13.7% of per capita indoor, residential water use is from leaking fixtures in the United States. They also did not find a significant difference between cities and their percentages. At the level of the municipality and distribution system, the percent of water lost varies by location. In older U.S. cities, losses range from 25 to 30 percent. Newer cities, like those in the Phoenix Metropolitan area, lose between 3 and 8 percent of their water. Mexico City loses 40 to 60 percent of its water (McKinnon 2007). The existence of these leaks is not generally known to utilities and end-users.

Even when municipalities and end-users suspect or know they have a leak, it is often very difficult to pinpoint the location of the leak. Large leaks that cause water puddles or catastrophic failures are easily found and dealt with. It is the smaller leaks that leave no evidence that are an issue because they can continue for years without resolution. Small toilet leaks make no sound and often go undetected by the consumer (Alliance for Water Efficiency n.d.(a)). Irrigation leaks are often discovered only after a professional inspection (City of Phoenix 2009). Even some large leaks go undetected (Britton et al. 2008). The most common practice for finding leaks in the distribution system is acoustic surveying. This method of locating leaks is time and labor intensive (Lin et al. 2008).

Another issue that results in water losses is inadequate metering.

Residential water meters can typically only detect a flow greater than one pint per minute. For the utility, this means that any flow below this will not be charged to the customer and represents a water loss. On the end of the consumer, if there is a leak or combination of leaks that are flowing at less than a pint per minute, there will be no way to detect the leak exists using the meter. This is significant since a constant leak of a half pint per minute results in almost 33,000 gallons of lost water per year. For larger users (a hospital, for example), the sensitivity gets even worse – up to one to three gallons per minute goes undetected. Older meters are also less accurate than newer ones. This is in part due to the advancement of technology, but is also due to the break-down of meter components (Kenna 2008). When a residential meter is 10 years old, its sensitivity can be reduced to two to three pints per minute (Alliance for Water Efficiency n.d.(a)). Not only are typical meters insensitive, they can also be tampered with or damaged without anyone knowing, resulting in additional water losses and inaccuracies. Also, utilities often choose not to meter certain end-uses (such as fire hydrants). When all of these unmetered uses and losses are combined, accurate monitoring of the system may become limited.

#### Water Waste/Over-Use

Water over-use, i.e., using more water than is necessary for a particular function, is widespread in residential, commercial, industrial and agricultural applications. There have been many efforts in recent decades to improve the efficiency of water use. Examples include educational campaigns to turn off



fixtures when not in use, laws that require the use of low flow fixtures, and automatic fixtures in many public restrooms. There is evidence that the systematic implementation of low flow fixtures has already had a significant impact on water usage rates. For example, between 1990 and 2008, total water consumption has remained relatively stable in Phoenix, Arizona, even as the number of total water accounts has increased by over 100,000. Research indicates that the installation of low-flow fixtures in new homes and replacements in old homes is at least partially responsible for this trend (Kieffer and Miller 2010).

One area where water over-use may have much potential to be addressed further is in the overwatering of urban landscapes in water scarce regions. Landscape watering is significant in these locations, where more than 50% of the total household water used goes to landscaping, especially in the summer months. Comparing three U.S. cities, a residential home in Las Vegas may use 100 gallons per day of water for outdoor uses, while Atlanta may use 21 gallons and Seattle 9 gallons(Cooley and Gleick 2009).

In wetter regions, people rely more on rainfall to take care of their landscapes. In more arid regions, however, it is up the end-user to apply the appropriate amount of water to their landscape, and because they are in an arid region, the water users do apply is considered to be more valuable and should not be wasted. Unfortunately, it is not easy for an individual to determine how much water their landscape needs at any given time. It is affected by many factors including plant types, climate, season, daily weather conditions, and so on. It is not reasonable to expect a water end-user to discover the perfect water schedule

on their own and make changes to their watering habits on a daily basis. The result is that most people over-water their landscapes, because the loss of their landscape to under-watering is a much greater risk than any negative effect from overwatering (Igo 2010).

### Water Quality

Water is continuously monitored for quality while it is in the water treatment plant. Once it leaves the treatment plant and enters the distribution system and then end-use pipes, however, monitoring is usually limited. Thirty to sixty percent of contamination events occur in the water distribution system. These events are often detected by consumers who have already been exposed. Then, it may take days to identify the source of the event in order to fix it (PUB 2011a).

The water quality in the drinking water distribution system can be affected by several factors. Water age is one issue where water is contained within the distribution system long enough that the protective disinfectants in the water are depleted (U.S. Environmental Protection Agency 2002). Pressure differentials in pipes are common and allow contaminants from the surrounding environment to enter the system through pipe connection seals and cracks (Karim et al. 2003). Pipe installation, repair, and replacement can also introduce contaminants to the system (Sadiq et al. 2006). Biofilms can grow and become stable inside pipes, which in turn can harbor pathogenic organisms (Hall-Stoodly and Stoodly 2005). The pipes themselves can corrode and leach materials, such as metals, into the water as well (Sadiq et al. 2006). It is also possible for targeted attacks to be made

through the water distribution system by purposely adding a dangerous contaminant, although the precedence for this is limited (Christopher et al. 1997).

Water contaminants of concern can vary. Examples of some pathogens include enteroviruses, Hepatitis A virus, and Norwalk virus (Karim et al. 2003). Contaminant intrusion from the environment can include pathogens, but can also include things like pesticides, petroleum products, and pharmaceuticals (Sadiq et al. 2006).

### Energy Consumption

The energy embedded in to convey raw water, treat raw water, and distribute treated water to end users can be significant. This means that water efficiency results in energy efficiency as well. The most energy intensive portions of the water delivery are usually source pumping and wastewater treatment (Cohen 2004; Hallin and Holton 2008). The U.S. Environmental Protection Agency (EPA) estimates that it takes an average of 1.5 kilowatt-hours of energy to convey, treat, and distribute one thousand gallons of drinking water in the U.S. (U.S. Environmental Protection Agency 2010). For Phoenix this value is estimated to be 6.47 kilowatt-hour per thousand gallons (Hallin and Holton 2008) and for the southern Los Angeles basin the estimate is 9.9 kilowatt-hour per thousand gallons (Cohen 2004). This larger energy consumption is mainly due to the long distances water must be conveyed from source to drinking water treatment plant. For reference, a standard 100 watt light bulb that is on for 10 hours consumes 1 kilowatt-hour of energy.

In addition to the energy consumed just to treat and transport water, undetected leaks and biofilms can also increase energy consumption. Leaks in the distribution system result in a loss of water pressure. Energy is required to rebalance this pressure loss. In turn, increasing the pressure actually increases the severity of the leaks, which means more water and energy lost (National Drinking Water Clearinghouse 2001). Biofilms increase the frictional resistance in pipes, slowing the water down, resulting in increased pumping to compensate (Barton et al. 2008).

### *Resiliency Issues in Urban Water Systems*

#### Accelerated Main Breaks

The phenomenon of accelerated main breaks is a simple and illustrative example of a resiliency challenge for water systems. Main breaks can shut down a neighborhood for a period of time and requires immediate response by repair crews. There is a large cost associated with the repair of main breaks and the damage done to surrounding infrastructure. In addition, there are social costs when people have an interruption in their water service, or when traffic flow is affected in order to repair the situation. Occasionally, these events can cause injury and death as well (Stoianov et al. 2007).

Pipes normally break down due to age. Their breakdown can be accelerated, however, due to corrosive elements in the water or surrounding the pipe, high water pressure, pressure transients, vibrations, and traffic loads (Hunaidi et al. 2005). Eventually, the stress in the pipes may reach a point that

causes a leak and/or main break. Alternatively, a large stressor or hazard, such as an earth quake can push the stress on the pipe over the edge and cause a main break. Of course, if the magnitude of the disaster is large enough, a main break can occur on a new, unstressed pipe as well.

Preventing pipe deterioration, as well as finding and fixing stressed pipes and leaks, is time consuming and costly. Municipalities often run on stringent budgets and may cut corners in order to ensure just basic water delivery, rather than maintaining and upgrading pipes. Main breaks are costly too, though, so some resources are expended to find and fix leaking and stressed pipes. Some of the tools that are currently used to manage the problem include water audits, pressure management, and leak surveys. The traditional methodologies for these activities are quite time and labor intensive. For example, distribution leak surveys require a lot field work that includes turning valves on and off and moving along the distribution system with portable leak detection devices (Hunaidi et al. 2005).

### Drought

Drought is currently a resiliencies challenge in many areas and climate change may increase the magnitude, frequency, and locations of impact (Mansur and Olmstead n.d.; Gertner 2007). A very typical strategy that municipalities employ to deal with short-term drought is to impose blanket, outdoor watering restrictions on residential customers (Mansur and Olmstead n.d.). There are several downsides to this strategy. First, it requires the type of enforcement that involves patrolling streets to look at people's lawns, which is resource intensive,

and neighbors reporting each other, which is socially negative. Second, it may result in a loss of a household's landscaping, which they would need money to replace. This type of loss would affect residents unequally, as it would be a heavier financial burden on lower income people. Lastly, it may not be an adequate enough strategy in times of extreme or long-term drought.

Long-term drought planning does occur and is a complex process that requires a lot of data and often relies heavily on models to make decisions. The most recent drought plan for the State of Arizona cites a lack of sufficient data and instruments to predict drought and mitigate its impacts. Two of the mitigation strategies that Arizona has chosen include increasing water storage and conservation (State of Arizona 2004).

#### Physically Destructive Disasters

As mentioned in the previous section, physical disasters can cause water mains and other water infrastructure to break. Although the mechanism for such breaks is more obvious when considering an earthquake, any type of disaster can potentially damage water infrastructure. For example, as mentioned previously, the destruction of the World Trade Center in a terrorist attack actually significantly destroyed water mains (O'Rourke 2007). Disasters can also shut down water treatment facilities and prevent the distribution of drinking water to taps. Events such as flooding can overwhelm sewer systems and prevent the proper disposal of wastes. Dams, pumps, reservoirs, and other facilities and infrastructure can be damaged either from natural forces or human causes (Haines et al. 1998).

Concern about increasing terrorist threats to infrastructure has increased over the past several decades (Meinhardt 2005). The number of natural disasters and the damage caused by natural disasters has also increased. More people are moving into cities, which generally increases the impact of disasters when they hit. It is also believed that climate change will further increase the frequency and magnitude of extreme weather events in the future, including drought. It is becoming increasingly important to find ways to prevent and mitigate these increasing threats to our urban infrastructures (Karl et al. 2008).

#### Water System Poisoning

Although there is very little precedence for the intentional poisoning of a water systems, the potential for it to be done exists (Meinhardt 2005). Water distribution systems are generally not secure against tampering, and because little monitoring is done on the water distribution systems, tampering would generally go undetected. Obviously, adding large quantities of some compound might become noticed, but there are some compounds that could be added discretely, in small quantities and still do significant damage. Additionally, with the advances in bioengineering and nanoengineering, there could be new compounds or technology that could pose a threat in the future.

#### *Potential Sustainability Benefits of Smart Water Grid*

A system cannot be managed properly without adequate information about that system. One major goal in developing a smart water grid is to increase the data gathered. The more the fate of every drop of water in the system is known,

the better users and managers of the system will be able to make good decisions about the system. By installing smart meters at various locations in the system and installing end-use tracking devices at the end-use locations, managers and users will know how water is being used and where potential problems, such as leaks, are located. Better monitoring of the distribution system for pressure and water quality also helps managers make better decisions.

A smart water grid gives water managers the power to prioritize repairs and maintenance of the treatment and distribution system they manage. It also gives managers the power to end waste at the end-use level. Even though wasted water at the end-use level is often revenue for the water utility, wasted water is a burden on water system at the level of supply management and also operations. Wasted water is also a burden on society as a whole. Water utilities also can provide an extra benefit to users by notifying them of the existence of leaks and other problems at their location. This gives users one less thing that they have to keep track of in their lives.

Water quality is another sustainability issue in the water distribution system that smart water grid could address. For example, biosensors could identify growth of biofilms. Removal of biofilms improves water quality and reduces pumping energy in the water distribution system. Multi-contaminant sensors can indicate potential areas of contaminant intrusion that would normally go undetected. Also, smart flow meters can alert managers when water age is high. Advanced water age in pipes indicates that protective disinfectants have been depleted resulting in reduced water quality.



At the end-use-level, smart irrigation controllers and end-use sensing devices give consumers more control over their water use. Smart irrigation controllers simplify landscape watering for consumers. The problems that come with overwatering and under-watering are avoided. For overwatering, water waste is avoided. For under-watering, landscape replacement due to dead vegetation is avoided. End-use-sensing devices can help in leak detection by helping to discover which water fixture is leaking. End-use-sensing devices also help consumers understand their water use behavior better. This knowledge can then be used to make changes to water consumption patterns.

Additionally, a smart grid can improve the pricing of water. Knowing the disaggregated end-use patterns of water through the installation of end-use sensing devices can help set up appropriate conservation-promoting tiered pricing structures. Lower water rates could be charged for necessity uses, for example, by assuming that water used from the kitchen faucet is for drinking water and cooking. Real-time, continuous water meter data also helps keep tiered pricing accurate, when thresholds are crossed, and allows the tiers to be changed based on changes in consumption patterns.

The American Water Works Association (AWWA) reports that conservation-promoting tiered pricing does not work alone, because consumers generally would not notice that their water rate was increasing as their consumption increased. The AWWA notes that consumers would need to be informed about the new rate structure and how it works (American Water Works Association 2012). Smart water grid could make it even easier for consumers to

navigate a tiered structure and allow them to save more water and money. Smart water meters with web-based tools would allow consumers to track both their water consumption and their water rate on a daily basis. They would be able to know within a reasonable amount of time if they are getting close to moving up to another pricing tier and would be able to act accordingly. The old paradigm of delivering water information monthly to consumers may not be enough for consumers to make informed decisions on their water use in order to respond to tiered pricing structures.

A second goal of the smart water grid is to deliver the same service with less impact. This means providing and using water in a way that is efficient and cost effective. Smart water grid has great potential to reduce waste in a way that uses less time and resources than the current system. For example, implementation of a smart grid has the potential to improve and streamline auditing, water quality testing, pressure management, and leak surveys.

An example of how this can be implemented with leak surveys is through the automation of one leak surveying method, step testing. Traditionally, step testing involves manually monitoring the flow rate on a section of pipe, while manually turning off valves in order to pinpoint the section of pipe a leak is located in – a water flow in an isolated pipe means there is a leak. With a smart step testing system, smart valves and smart meters can replace workers out in the field and requiring only one at a computer terminal. The process could even be automated, only requiring human attention if something goes wrong.

Pressure management can also be streamlined through smart technology. Smart pressure meters and smart pumps can adjust pressure in different parts of the system as needed, either at a computer center or automatically. Pressure management reduces pipe deterioration, which saves energy because leaky pipes lose pressure and require more energy to balance.

#### *Potential Resiliency Benefits of Smart Water Grid*

The main way that smart water grid improves resiliency is by providing an increasing amount of information about the system. As water grids currently stand, there is little information before water reaches the treatment plant and after it leaves. This means that there are many small problems in the system that go undetected and then can compound and become catastrophic failures.

For example, many small leaks exist in water mains. Unfortunately, when these leaks go undetected, they continue to worsen, resulting in main breaks that can disrupt the system for a period of time. When all these small stressors are added together, the potential for many failures happening at once, or the susceptibility to widespread failure from an acute threat, increases.

Smart water grid can help prevent pipe deterioration and help detect problems when they occur. Smart pressure management, for example, can help detect pipe damaging high pressure spots inside the distribution system, by using smart pressure meters to detect areas of high pressure and then use smart pumps and valves to reduce pressures in these areas. When pipe breakdown does occur, smart step testing can detect small leaks before they become big problems.

During disaster, flood sensors can alert the authorities of problems as they happen and smart valves can then isolate flooding immediately. Smart pumps can also ramp up to deal with increased water. Smart water grid also has the potential to detect and quickly remediate or even prevent attacks on the system. Water quality sensors could detect the poisoning of the water supply and smart valves can isolate contaminated water. There can also be sensors installed that detect intruders or tampering.

The smart water grid also has the potential to improve response to short-term and long-term drought. For example, water restrictions could be managed better with a smart water grid system. Rather than using a simple lawn watering restriction that requires field enforcement and the potential loss of landscapes, a more flexible approach can be taken. If users are able to monitor their own water use on a disaggregated and real-time basis through the use of smart meters and end-use sensing devices, they can make decisions about how to save water during a drought. At the same time, utilities will be able to monitor on a real-time basis and from a remote location, what end-users are saving water during drought and what end-users are not.

Alternatively, smart water grid could support temporary drought pricing of water. In the same way that conservation-promoting tiered pricing and smart water grid can help people save money and conserve water on a daily basis through online tools and real-time data, drought pricing can also be supported by smart water grid. Consumers will be able to track their water rates and consumption more easily when drought prices are in use. If water utilities want to

change the drought pricing in the middle of a billing period, consumers will easily be able to see this when using their online tools and can adjust their use patterns accordingly.

On the broader level of long-term drought and regional water planning, water saved from the reduction of water losses could be banked through water storage projects, creating more water availability during times of drought. Additionally, real-time data from the smart water grid can feed into water resource planning and modeling, making drought and long-term water planning a more accurate and dynamic process.

Smart water grid can also help other infrastructure grids stay resilient. For example, water used during peak electricity times can stress the electrical grid, because of the electricity used by water heaters, washing machines, and dishwashers. Water utilities can work with electrical utilities to reduce water consumption during peak electricity times using data collected from the water grid (House and House 2012).

### *Summary of Potential Benefits*

Tables 1 and 2 summarize how smart technology could be used in a smart water grid to address sustainability and resiliency issues.

**Table 1** Summary of smart technologies/solutions and their uses.

<b>Smart Technologies/Solutions</b>	<b>Explanation/Purpose</b>
<b>1</b> End-Use Sensing Device	<ul style="list-style-type: none"> <li>• to allow users to come up with own conservation strategies through greater knowledge of water use</li> <li>• to help locate water fixture leaks</li> </ul>
<b>2</b> Smart Irrigation Controller	<ul style="list-style-type: none"> <li>• to reduce water wasted on landscaping</li> <li>• to restrict water to landscaping during times of drought</li> </ul>
<b>3</b> Contaminant Sensor	<ul style="list-style-type: none"> <li>• to detect contaminants, biofilms, or disinfectant loss</li> </ul>
<b>4</b> Smart Meter	<ul style="list-style-type: none"> <li>• to help in leak detection</li> <li>• to monitor flow for water age determination</li> <li>• to monitor pressure for pressure management</li> <li>• to support tiered or drought water pricing</li> </ul>
<b>5</b> Smart Valve	<ul style="list-style-type: none"> <li>• to isolate contaminated water</li> <li>• to prevent flooding</li> <li>• to isolate leaks</li> <li>• to help manage pressure in pipes</li> </ul>
<b>6</b> Smart Pump	<ul style="list-style-type: none"> <li>• to save energy by ramping up and down based on environmental conditions</li> <li>• to respond to flooding by ramping up</li> </ul>
<b>7</b> Flood Sensor	<ul style="list-style-type: none"> <li>• to detect dam and embankment stress or failure</li> </ul>
<b>8</b> Smart Step Testing	<ul style="list-style-type: none"> <li>• automated process to find leaks in water mains using smart valves and smart meters</li> </ul>
<b>9</b> Smart Pressure Management	<ul style="list-style-type: none"> <li>• automated process to reduce pipe breakdown using smart pressure meters, smart pumps, and smart valves</li> </ul>

**Table 2** Summary of sustainability and resiliency challenges for urban water distribution systems and relevant smart technologies/solutions.

<b>Sustainability and/or Resiliency Challenge</b>	<b>Summary of Problem</b>	<b>Potential Smart Solutions</b>
<i>Water Loses, Leaks, and Waste</i>	<ul style="list-style-type: none"> <li>• Municipal water losses range from 25-30% in older, U.S. cities<sup>A</sup></li> <li>• Household water leaks average 13.7% and residents are generally unaware of small leaks, partially because regular meters cannot detect flows under one pint per minute<sup>B</sup></li> <li>• Users of traditional irrigation controllers tend to overwater landscapes<sup>C</sup></li> </ul>	<b>1, 2, 4, 8, and 9</b>
<i>Water Quality (distribution system and end-use)</i>	<ul style="list-style-type: none"> <li>• Advanced water age in pipes reduces the amount of protective disinfectants<sup>D</sup></li> <li>• Contaminant intrusion, biofilms, pipe corrosion, accidental and intentional contamination events reduce water quality or poisons the water<sup>E</sup></li> </ul>	<b>3, 4, and 5</b>
<i>Energy Consumption</i>	<ul style="list-style-type: none"> <li>• Pumping energy is required to transport water</li> <li>• Leaks reduce pressure, which requires energy to rebalance – worsens leaking and causes a positive feedback loop<sup>F</sup></li> <li>• Biofilms reduce frictional resistance, which slows down water and requires more pumping<sup>G</sup></li> <li>• Energy to treat and transport drinking water can be high – up to 9.9 kw-h/1000 gal in southwestern U.S. locations<sup>H</sup></li> </ul>	<b>1, 2, 3, 4, 5, 6, 8, and 9</b>
<i>Distribution Pipe Breakdown</i>	<ul style="list-style-type: none"> <li>• Many stressors accelerate distribution pipe breakdown, while finding and preventing breakdown is costly and time consuming<sup>I</sup></li> </ul>	<b>4, 5, 6, and 9</b>
<i>Drought</i>	<ul style="list-style-type: none"> <li>• Current drought response strategies are overly simplistic and inflexible<sup>J</sup></li> <li>• Regional water models for drought planning may be based on old, limited data</li> </ul>	<b>1, 2, 4</b>
<i>Disasters and Terroism</i>	<ul style="list-style-type: none"> <li>• Destruction to facilities and infrastructure from flooding</li> <li>• Water contamination from accidental or intentional poisoning</li> </ul>	<b>3, 5, 6, 7</b>

<sup>A</sup>McKinnon 2007

<sup>B</sup>Mayer and DeOreo 1999; Britton et al. 2008; Alliance for Water Efficiency  
n.d.(a); City of Phoenix 2009; Kenna 2008

<sup>C</sup>Hunaidi et al. 2005

<sup>D</sup>U.S. Environmental Protection Agency 2002

<sup>E</sup>Karim et al. 2003; Hall-Stoodly and Stoodly 2005; Sadiq et al. 2006; Christopher  
et al. 1997

<sup>F</sup>National Drinking Water Clearinghouse 2001

<sup>G</sup>Barton et al. 2008

<sup>H</sup>Cohen 2004

<sup>I</sup>Cooley and Gleick 2009

<sup>J</sup>Mansur and Olmstead n.d.

## **Smart Water Grid Adoption**

### *Potential Disadvantages*

Managing water with a smart system also entail risks. One risk is that a smart water grid reflects an increase in interconnectivity of infrastructures: water, Information and communication technology (ICT), and electricity. This creates the potential for a failure at one level (e.g., a power outage) to ripple through other infrastructures (O'Rourke 2007). This can be mitigated to some extent by having a smart water grid that is powered by distributed energy, such as solar cells, water pipe turbines, or long-life batteries, rather than centralized power and



transmission lines. Distributed energy is, in fact, compatible with many aspects of the smart water grid, because it is often not easy to connect smart technology to the main power grid, due to technical or jurisdictional issues.

A highly networked, automated system is susceptible to targeted attack (Allenby and Fink 2005). If someone wanted to hack into and shut down a water system, they would have a much easier time accomplishing this with a smart water grid system than with a manual system. This risk could be mitigated with increased network security measures.

Using smart water grid to enhance sustainability and/or resiliency can also create disadvantages for the other. For example, if smart water systems are used to dramatically reduce wasted water, which is a sustainability benefit, an additional resiliency challenge is created in responding to drought through waste reduction. Theoretically, this issue could be mitigated through good planning practices, such as water banking. While resiliency and sustainability are often thought to be cooperative, when applied in practice, trade-offs emerge (Fiskel 2003).

Another concern is burden shifting. A smart water grid means adding information technology and electricity to parts of a system that did not previously have those things. Do the environmental impacts of adding these components justify the environmental benefits? Life cycle assessment (LCA) is one tool that can be used to determine this by comparing a smart water grid to a manual grid.

Social impacts are also a concern. A smart water grid requires a completely different type of workforce. Manual meter readers will be replaced by

computer savvy technicians and engineers. Can the existing workforce be retrained, or will they be replaced with more technically proficient workers? Also, will the number of workers needed to run a smart water grid be less than the number to run a manual grid? If implementing a smart water grid results in fewer workers being employed, negative social consequences could arise.

### *Implementation Challenges in the United States*

The smart phone is a marvel of modern information technology owned by hundreds of millions of consumers around the world. In contrast, much of the technology for water distribution and use is similar to that of fifty, or even a hundred years ago. Outside of the treatment plant there is little use of information technology in water systems. Clearly, there are structural differences in markets for personal information products versus water infrastructure underlying this dramatic gap in adoption. It is important to understand the barriers to the smart water grid adoption and in this section some issues are proposed.

#### Institutional Barriers

The main reason smart water grid is not widely implemented in the United States is due to the institutional heritage of the water industry as well as significant cost barriers. U.S. water utilities were founded on principles of delivering an invisible service at the lowest cost possible (Rothstein and Galardi 2012). The philosophy of smart water grid challenges this attitude by valuing information and a quality of service that goes above and beyond just meeting the minimum of standards.

In order for smart water grid to succeed as a movement in the United States, water managers and policy makers will have to truly believe that the old culture is not working anymore and that smart water grid is one way to make a change. There is plenty of evidence that the old culture is not working anymore as has been highlighted in the previous sections of this thesis by emphasizing the problems with water quality, quantity, infrastructure resiliency, lack of infrastructure investment, etc. The AWWA is one group that has been working to get water infrastructure “out of the ground and into the light”, which can be seen in their publication, *Buried no longer: Confronting America’s water infrastructure challenge*.

Another issue that can become a barrier is the diversity in types of water municipalities and governance structures for them across the country. There are privately-owned utilities and publicly owned ones. Decisions about water pricing and other oversight decisions could be made by elected officials or hired professionals. Forthcoming research done by Sara Hughes at the University of California found that the efficacy of voluntary environmental programs for promoting water conservation in California depended heavily on the type of water utility and governance structure.

### Cost and Funding

Given the lack of investment in the United States to maintain current water systems, upgrading them with modern technology presents a particular challenge. The current U.S. system has a major leak problem; it is estimated that 3.4 billion dollars is lost each year by municipalities due to water loses, which is mainly

leaks. It is estimated that it will take 325 billion dollars over the next 20 years to implement needed upgrades in the U.S. system, including new pipes and meters (Kenna 2008). Some of this money will be used for things like smart meters, but additional funding is needed to implement a more expansive smart water grid system.

Acquiring this needed funding is a big obstacle. Water and wastewater infrastructure receives an estimated quarter of public funding allocated to transportation infrastructure (Brzozowski 2010). Part of this is probably a case of out of sight, out of mind. As long as water is coming out of people's taps, they generally do not care if there is invisible waste or quality issues in the system. Compare this to the transportation system, where people are acutely affected psychologically and sometimes physically by traffic jams, poorly designed systems, and deteriorating infrastructure.

The most probable dominating reason that funding is such an issue for smart water grid is probably due to the fact that there is no federal level water department to fund research and development for smart water grid. The electricity sector has the U.S. Department of Energy. For the water sector, there is only a patchwork of smaller programs, like the WaterSense program under the EPA, for example.

Water is a monopoly. While smart electrical grids hold promise to create new power markets, this is unlikely to happen for the smart water grid. Water resources are unlike smart electrical grids – the application of smart technology to create producer markets does not work for water, because it is a resource

(desalinization aside). The general lack of incentives to innovate in utilities affects adoption of smart water grid technology. Capital is constrained in many areas.

There are also a lot of other small issues to consider. For example, water managers have to balance competing issues and regulations when deciding how to spend their money. When the EPA implements stricter water quality regulations, money that may have set aside for smart water grid may have to be diverted in order to meet new water quality standards. Also, implementing a smart water grid may require a complete upgrade in computer software and hardware. Many utilities still depend on outdated technology to get their daily work done.

One issue for both utilities and consumers is the cost and other negative effects of fixing leaks once they are found by the smart water grid. Distribution pipes are often underneath the infrastructure of the city, so accessing leaks to repair involves removing and repairing other infrastructure. Repair restricts use of those infrastructures, including roads, causing inconvenience to residents. At the home level, some leaks such as faucet leaks or toilet flapper leaks are easy to repair, but some are not. Leaks that occur underground or behind walls may require professional repair, which can be expensive and take many years to pay back to the consumer through lower water bills (Britton et al. 2008).

### Water Pricing

Another big issue is that water is still relatively inexpensive compared to electricity, which is one of the reasons the smart electrical grid development is ahead of the smart water grid. Of course, these water prices are often subsidized, so the more the pricing of water reflects the actual cost, the more efficiency will

become important to people. Tiered pricing is one way to cost water better, and as mentioned in a previous part of this thesis, implementation of a smart water grid can help with this. Another reason smart electrical grid may be ahead of smart water grid, is that while smart electrical grid needs only to add the communication infrastructure to make it “smart”, water grid will additionally need to add power infrastructure to make it “smart”.

Raising water prices or moving to tiered pricing has its own barriers, too. One issue is that elected water boards may be hesitant to increase water prices, because they might be afraid it would be unpopular with their constituency. Another issue is the belief by water managers that the use of conservation pricing will decrease their revenues.

#### Scales and Divided Benefits

Water infrastructure changes slowly. Many system elements such as pipes, valves and meters last for decades. Barring changes in water regulations, keeping the existing system going can make sense when pieces are expensive and last a long time. A smart water grid system needs to achieve a certain size scale to realize many of its benefits. Generally speaking, the utility of a network increases with the number of nodes in the network. Incremental replacement of failed systems elements with smart technology will not realize these size scale benefits. This scale issue is qualitatively different for newly developing areas installing water infrastructure for the first time. Newly developing communities and countries have opportunity that older ones do not.

Additionally, although the utility is most often responsible for paying for the smart water grid, many of the economic, sustainability, and resiliency benefits of a smart water grid are divided among actors beyond the utility. For example, an end-use smart meter helps the utility via automated meter reading and improved flow data, but also provides value to the end-user by informing efficiency actions. Another example is that a more secure water system benefits society as a whole, but from the perspective of the water utility it is simply an additional cost. These differences in who bears the cost and who receives the benefit may be unbalanced.

### Community Concerns

Community or individual values could also be challenged by the implementation of smart water grid. If water utilities know how much water people are using from each fixture, people may feel that their privacy is being violated. People also may be concerned that hacked data could be used against them. For example, potential burglars could determine when occupants are on vacation, or radical groups could engage in the public shaming of high volume water users. Some people are also concerned about the radiation they may be exposed to from smart meters attached to their house; especially when installation of such devices is done without their knowledge or input (Barringer 2011). Additionally, installing smart water meters may result in people's water bills initially going up, since the newer meters can detect lower flows than the older ones (Kenna 2008; Alliance for Water Efficiency n.d.(b)).

Water utilities and government would be well advised to get public involvement before implementing a smart water grid, so that the community understands what the benefits and costs are to them, individually and as a community, as well as to allay any fears about privacy or radiation. For example, water bills will go up due to increased meter accuracy, but now the utilities can let consumers know whether they have leaks and fixing those leaks will help lower bills (Harris 2010a).

### Jurisdiction

A smart water grid will require that many different people and jurisdictions work together. This is highlighted in the previously discussed issue of powering and data transmission. Although it would be easier if water utilities could tap into peoples electrical and internet connection, it does not mesh with most economic/government structures. Private and public water utilities will have to work with the public, electrical utilities, internet and cell service providers, etc. in order to have a successful system. In fact, this may be a greater challenge for smart water grid than it is for smart electrical grid, considering that that there are generally more private and public water providers in an area than there are power providers. In the United States, there are a total of 410 electricity or electricity/gas entities and a total of 605 water/wastewater entities (The Utility Connection n.d.). Some solutions to this issue include the formation of regional task forces to oversee smart water grid implementation in the city; development of a cell frequency dedicated to smart grid (Simonite 2011); and the use of distributed power sources, such as solar cell, long-life batteries, and water turbines.



At the end-use level, water municipalities do not have the jurisdiction to ensure water quality or efficiency – it is the responsibility of the property owner(s) and users. Water municipalities and other groups can, however, educate the public about potential water quality issues at their locations and about household leaks. They can also offer incentives to fix leaks or test the quality of their water. For example, some water utilities already offer subsidies for consumer purchase of water saving devices such as smart irrigation controllers.

### *Potential Solutions to Cost Challenges*

#### Cost Savings from Smart Water Grid Implementation

Although the cost challenges associated with implementing smart water grid may seem daunting, smart water grid implementation at least offers long-term cost-cutting opportunities that sticking with the current system does not offer. Replacing already worn-out manual meters and other equipment with smart technology is an opportunity to reduce future costs, because a smart system is more flexible to changes than a manual system. Additionally, the increased efficiencies mentioned in this thesis that come from a smart water grid are basically revenues that can be re-invested in the system. Published case studies with cost-benefit analyses for smart water grid are lacking in the public literature, so it is not yet clear how promising these opportunities are.

#### Governmental Incentives

Although the long-term cost savings that come from smart water grid implementation are potentially promising, large up-front costs are still often

needed, and many utilities are reluctant to make such large investments without assurance of success up front. This is where the government can take a larger role in promoting smart water grid for the benefit of society.

Research and development funding is one way to promote smart water grid. This can be accomplished by appropriating funds to utilities, private companies, federal agencies, or research institutions for pilot projects. Singapore has taken on this model, investing large amounts of money into research done at both the local and global level and in both the public and private sectors. Taking this aggressive stance has made them the leader in smart water grid implementation, allowing them to be a source of innovative solutions that can be sold around the world, which provides an economic payoff for their efforts (PUB 2011a; PUB 2012b; PUB 2102c).

Another route is to legislate smart water grid implementation using voluntary environmental programs, or command-and-control legislation with either fines for non-compliance or by taking away funding for other projects for non-compliance. The California 20x2020 plan is an example of legislation that promotes smart water grid. Smart irrigation controllers are listed as an approved technology for meeting the water conservation goals in the plan. Additionally, any remaining unmetered water consumption in the state must end, with smart water meters being the preferred meter type to use (California Department of Water Resources 2010).

## **The Future of Smart Water Grid**

### *Technological Development*

At this point, much smart water grid technology already exists. However, the technologies that need the most future development, based on this research, include contaminant sensors (for distribution system and end-use locations), end-use sensing devices, and smart irrigation controllers. Contaminant sensors will need to be sophisticated in order to detect a wide array of possible contaminants at different concentrations; just measuring basic water quality parameters may not be enough. End-use sensing devices are not widely available, commercially, at this time. In order for end-use sensing devices to be commercially viable in the future, they will need to be inexpensive and relatively simple, while still maintaining a proper level of accuracy. Lastly, irrigation controllers are widespread in the marketplace, but do not deliver consistent benefits when it comes to water savings. More development in this area is needed (Mutchek and Williams 2010).

### *Integrating Individual Technologies into a Systems Approach*

The literature review for this chapter on smart water grid mostly resulted in papers addressing individual technologies or particular problems in the water grid. In order for the smart water grid to deliver the most benefit to society, however, a systems thinking approach, such as the one presented in this thesis, should be explored more. For example, when municipalities are considering smart

technology, just looking at technological components in isolation may not yield the same benefits as looking at technological systems using multiple technologies. One example given in this chapter is the use of smart step testing or smart pressure management. Having smart meters, smart valves, and smart pumps, and using them synergistically allows for two routine processes to become streamlined. This may yield more benefit than just installing smart meters. Creative ideas and research is needed to facilitate this type of systems approach.

#### *Environmental and Cost-Benefit Analyses*

There is little research in the public literature that seeks to analyze the successfulness of pilot projects pertaining to smart water grid. More publicly available cost benefit analyses and environmental analyses would be helpful to better understand feasibility of smart water grid, as well as the pros, cons, and trade-offs. The concern about whether the benefits of smart water grid outweigh the costs is not fully addressed, nor is the significance of the environmental impacts of electrifying and computerizing the entire water sector with smart technology. Publically available analyses that show how much money could be saved per gallon of water by implementing smart water grid, as well as LCA to determine the impacts of adding ICT are needed. The next section of this thesis seeks to at least try to fill in one of these gaps by presenting a life cycle based analysis of smart irrigation controllers.

## Chapter 3

# DESIGN SPACE CHARACTERIZATION FOR MEETING COST AND CARBON REDUCTION GOALS: SMART IRRIGATION CONTROLLERS IN THE SOUTHWESTERN UNITED STATES

## **Introduction**

### *Water Scarcity and Water Use in the United States*

The southwestern United States is the driest part of the country, and much of it was developed in conjunction with large water works projects intended to support an increasing population (Reisner 1986). In the recent past, Arizona and Nevada have been two of the fastest growing parts of the United States, but also the driest (Day and Conway 2009). The West is also the largest user of water for landscaping and agriculture in the nation. Eighty-five percent of irrigation withdrawals are used in 17 western states, with California, Idaho, Montana, Oregon, Colorado, Nebraska, Texas, and Arkansas being the largest users in all of the United States (Kenny et al. 2009). On the level of home water use, it is estimated that in Las Vegas 70% of residential drinking water is for exterior uses, which is mostly landscaping (Devitt et al. 2008). Compare this to Pennsylvania, where only 7% of household water is for outdoor use (U.S. Environmental Protection Agency [EPA] 2004). These factors, in combination with the possibility that climate change will make this part of the world even dryer, may result in a major water crisis in the future (Gertner 2007).

Looking at the energy-water nexus, the Southwest also uses more energy to treat and transport water than the average in the United States. The EPA estimates that it takes 1.5 kilowatt-hour/1,000 gallon (kWh/gal)<sup>1</sup> of energy to treat and transport drinking water in the United States (U.S. Environmental Protection Agency 2010). For Phoenix this value is estimated to be 6.47 kwh/1,000 gal (Hallin and Holton 2008) and for the southern Los Angeles basin the estimate is 9.9 kwh/1,000 gal (Cohen et al. 2004). These factors make it increasingly important to look for solutions that deal with the use of water for landscapes and agriculture in the Southwest.

#### *Water Conservation and Information Technology*

Information technology can potentially play an important role in water conservation. Smart water meters installed at homes and businesses can monitor water flows in a system on a real-time basis. When these data are transmitted to a computer, pipe leaks can be detected early and fixed. As it is now, many homes and businesses will never know they have a leak unless it reaches the surface or their water bill increases significantly (Hauber-Davidson and Idris 2006). Some home water sensing systems can determine how much water is being used and by what water fixture. HydroSense is a sensor that can be attached to a single pipe on the home and uses pressure differentials to find the “signature” of each water fixture in the house. These data can be transmitted to a computer, and consumers can then track their water usage, over time and by fixture (Froehlich et al. 2009). Another information technology that can be used in homes and businesses is the

smart irrigation controller. These controllers use local evapotranspiration (ET) rates and/or environmental data to determine the watering schedule for a landscape and have been found to save water when compared with traditional controllers (U.S. Bureau of Reclamation 2008).

### *Smart Irrigation Controllers*

An smart irrigation controller is similar to a traditional irrigation controller, insofar as it controls a landscape's sprinkler or drip system. The difference, however, lies in how efficiently it does the job. The functionality of a traditional irrigation controller includes setting the days and amount of time to run the sprinkler or drip system. It is up to the user to determine and adjust the watering schedule for their landscape. The smart irrigation controller, on the other hand, has the goal of giving the landscape exactly the amount of water it needs, at any given time, without much user interaction. Two different strategies that smart irrigation controllers employ to meet this goal exist: soil moisture sensing and ET tracking.

Soil-moisture-based smart irrigation controllers include one or more soil moisture probes that are installed in the root zone of the landscaping. Information from these probes is transmitted to the controller, and the controller determines the water schedule based on this information. Weather-based smart irrigation controllers use meteorological data to determine the landscape's watering schedule. These controllers vary in how many parameters they measure and whether on-site sensors or area weather stations with remote data transmission are

used. Some of these controllers also use historical weather data, in addition to or instead of real-time data. Figure 2 shows three basic types of residential smart irrigation controllers. Smart irrigation controllers are also known to use other data to determine schedules, such as landscape type, sprinkler type, and slope factors.

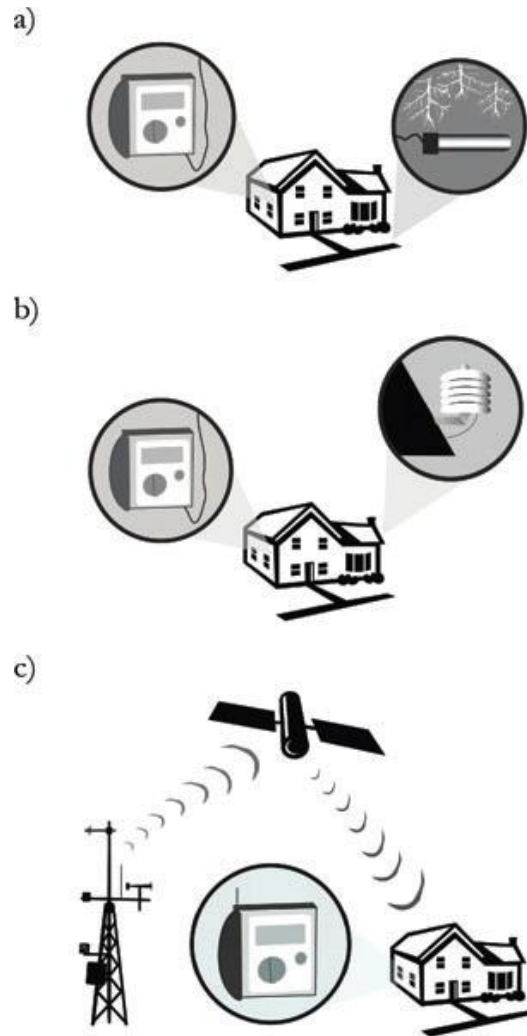

**Figure 2** (a) A soil-based smart irrigation controller; (b) an on-site sensor, weather-based smart irrigation controller; (c) an off-site weather station weather-based smart irrigation controller. Source: Frisco Public Works (2010).



### *Smart Irrigation Controller Studies*

A number of studies have been conducted on smart irrigation controllers, with most concentrating on their potential water savings for the residential and small commercial sectors. Some studies have been implemented by educational institutions and some by government agencies and water utilities. The studies were conducted mostly in western states, including California, Colorado, Washington, Nevada, Florida, Oregon, Utah, and Arizona. There have also been studies in Western Australia (U.S. Bureau of Reclamation 2008).

The largest study on smart irrigation controllers to date was done for the State of California. This study assessed promotion programs in different parts of the state; it was not an experimental study aimed at identifying the effect of different variables on system performance. Water districts across the state implemented their own smart irrigation controller programs, with the data being collected and analyzed from these programs. This one-year study included 2,294 sites, 14 controller brands, residential and commercial applications, volunteer and targeted high use participants, and both professional and self-installation. An overall water savings (adjusted for weather) of 6.1% was found compared with the pre-study year, with 41.8% of sites increasing their water consumption, 56.7% decreasing their consumption, and 1.5% having no change in water consumption (Mayer et al. 2009).

Two scientifically-controlled studies include one by Devitt and colleagues (2008) in Las Vegas, Nevada, and one by Quanrud and France in Tucson, Arizona

(U.S. Bureau of Reclamation 2008). The study by Devitt and colleagues (2008) included the installation of Hydropoint smart irrigation controllers (Hydpoint Data Systems, Inc., Petaluma, CA) at residential households. They compared the water savings and plant health of the group receiving smart irrigation controllers to a group of households receiving only landscape watering education, and a control group. They found an average 20% savings of outdoor water, compared with a slight increase in water use in the other two groups. This study not only indicated water savings from the use of a smart irrigation controller, but it also showed that depending on a homeowner to use educational information solely to save water may not be an effective strategy. The study by Quanrud and France was also applied to a residential setting and compared brands. The brands compared were Hydropoint, WeatherMiser (WeatherMiser Energy Efficiency, Inc., Albuquerque, NM), and Rain Bird MS-100 (Rain Bird Corporation, Azusa, CA). Water savings were 25%, 3.2% and 4.3%, respectively (U.S. Bureau of Reclamation 2008).

#### *Smart Irrigation Controllers vs. Other Strategies*

Smart irrigation controllers are unique compared to other strategies for landscape water conservation. For a consumer with an already functioning sprinkler system, little is needed from them to potentially save significant amounts of water. The controller only needs to be switched out, along with some additional installation time and maintenance. The smart irrigation controller is adapted to the most common existing system in the Southwest: single-family

homes watering their varied landscapes with a sprinkler/drip system using city drinking water.

Whether this is a sustainable system should certainly be explored. The answer to this question may not be simple, however. For example, a study by Martin (2001) found that many xeric landscapes are over-watered by their owners, indicating that conversion of mesic landscapes to xeric landscapes is not a simple solution for water conservation. Also, less mesic landscape results in a greater urban heat island effect, which in turn increases evapotranspiration rates (Wentz and Gober 2007; Martin 2008). Another study by Martin et al. (2003) showed that 70% of homeowners in Phoenix, Arizona prefer landscapes with at least some lawn. This preference would limit number of households in the Desert Southwest who could water their landscapes through rainwater harvesting, because only enough water could be harvested to support a xeriscape.

On a centralized scale, watering of landscapes with non-potable water can be seen in some communities that are set up with flood irrigation. In addition, some communities have installed “purple pipes”, giving the ability to deliver treated wastewater from the water treatment plant to landscaping. The installation of “purple pipes” and the redesign of communities to use less landscaping are good solutions for new communities, but may not be appropriate for existing communities. Onsite, greywater systems seem to be a good solution for existing communities, but will require a truly motivated user. In addition, there is no reason that smart irrigation controllers cannot be used in conjunction with the other strategies mentioned above. It would just need to be determined if adding a

smart irrigation controller to another strategy would provide an additional benefit or a cost.

### *Scope of Analysis*

The popularity of smart irrigation controllers in the municipal sector has been increasing in recent years. Between 2004 and 2007, the number of available brands has increased 400% (U.S. Bureau of Reclamation 2004, 2007). Many water utilities have been promoting smart irrigation controllers to their customers as well. Smart irrigation controllers remain expensive, however, and according to the case studies discussed in the previous section, exhibit considerable variability in water savings. If smart irrigation controllers are to be diffused via market forces, it is important that they deliver net economic benefits as well as substantial water savings to consumers. It is not clear how beneficial current designs and practices are to consumers in different circumstances. In addition, it is important to be careful to ensure that smart irrigation controllers do not induce unintended environmental externalities. In particular, smart irrigation controllers are more electronically complex than traditional irrigation controllers and require a degree of additional energy use in their manufacture and operation. Figure 3 illustrates a life cycle for a smart irrigation controller system.

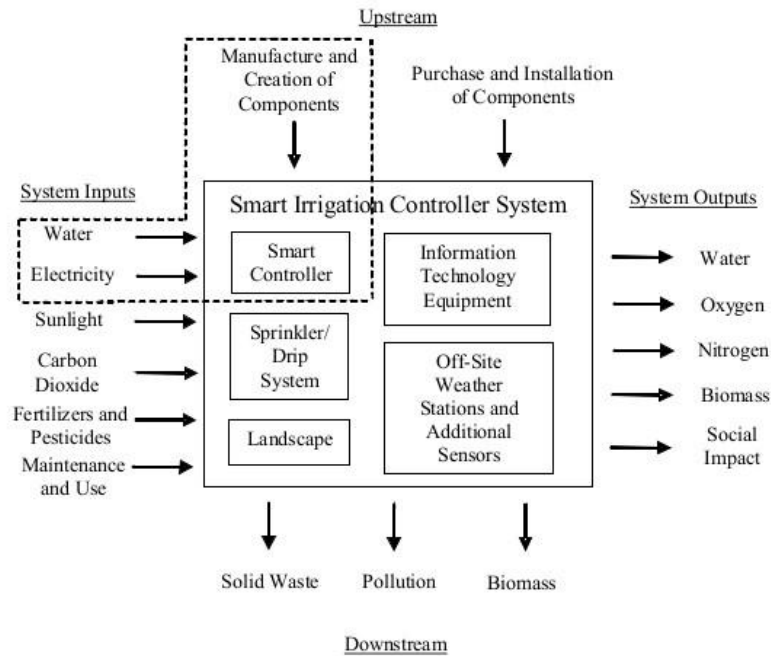

**Figure 3** Life cycle of a smart irrigation controller system. The dotted line represents the main boundary of the study; other components are included in this study as well.

To inform the design and operation of future generations of smart irrigation controllers, we undertake analysis to establish design/operating parameters needed to realize economic and environmental performance targets under different operating conditions. In the next section, we develop a general method to scope the design space needed to meet the target life cycle impacts.<sup>2</sup> We then implement the method for residential smart irrigation controllers using the design parameters of controller price and water savings achieved. The parameters of each operating condition studied include the water price, electricity

price, and grid carbon intensity associated with six different urban areas in the southwestern United States. In the final section we discuss how these results relate to strategies for developing improved controllers.

### **Design for Environment Method: Meeting Multiple Performance Goals under Variable Operating Conditions**

In this section, we develop a method that maps out the multi-criteria design space for a product to meet economic and environmental objectives. This work is part of design for environment (DfE), an umbrella label for concepts and methods aimed at integrating environmental considerations into product design (Graedel and Allenby 2003). Environmental considerations can be considered from a life cycle assessment (LCA) perspective (Keoleian 1993). The central challenge is the understanding of how multiple design parameters affect multiple environmental issues, as well as economic performance. Allenby (1991, 2000) developed a matrix method to aid designers in understanding and navigating this multi-parameter space. Another stream of work aims to characterize the functional relationships between design attributes and their environmental and economic performance, and then develop optimization approaches. Ishii and collaborators (1994), for example, developed a model linking design attributes of electronics with the efficiency of disassembly to identify designs that enhance recyclability. Azapagic and Clift (1999) framed the multi-criteria design problem as a linear programming model and explored trade-offs between objectives using

methods such as the Pareto optimum. Michalek and collaborators (2004) embedded design parameters into larger system models, aiming to maximize profit to producers, while meeting external environmental design constraints.

Here we take a different track on the use of functional relationships between design parameters and environmental and economic performance. The method is targeted at technology still in development; attainable performance is assumed to be unknown (e.g., how much water could be saved with a smart irrigation controller). The intent is to formulate specific goals (e.g., zero emissions) for product characteristics that meet multiple environmental and economic objectives. Designers then use these goals as targets for developing the next generation of products. The method is also designed to address how variability in operating conditions (i.e., local conditions—economic, social, mechanical, environmental, etc.) affects environmental and economic performance. The purpose is to identify performance goals robust enough to deliver benefits under different operating conditions. Though not all technologies will display variability in operation that significantly affects design, this is clearly relevant for smart irrigation controllers, and there are many other examples.

To develop this method, we first recap the basic life cycle impact equation that applies to manufactured goods:

$$\begin{aligned} \text{Life Cycle Impacts (LC\_impacts)} = & \text{Impacts from Resource Extraction} + \\ & \text{Manufacture} + \text{Transportation} + \text{Purchase and Installation} + \text{Maintenance} \\ & \text{and Use} + \text{End Of Life} \end{aligned} \quad (1)$$

The life cycle impacts chosen can be based on economics, greenhouse gases, energy, or water, for example. Life cycle impacts (LC\_impacts) can be written as function of design/performance attributes of the technology being considered and operating conditions to which the technology is subjected (e.g., different geographical locations, which have differing local environmental conditions):

$$LC\_impacts_l (D_1, \dots, D_n; O_{1,\dots,m}), \quad (2)$$

where D is a design parameter and O is an operating condition. The index l denotes the life cycle impact of concern, n is the number of design parameters considered, and m is the number of operating conditions. Each operating condition can have a number of different variables.

Given a set of functions relating design parameters and operating conditions to a set of life cycle impacts, the next step is to establish target performance for each impact:

$$LC\_impacts_l (D_1, \dots, D_n; O_{1,\dots,m}) = T_l, \quad (3)$$

where T denotes the target life cycle impact value. For example, T can be chosen to be zero, meaning zero life cycle impacts.

The design space is n-dimensional. The method uses the equations above to find the design space that meets all target life cycle impacts, which in mathematical terms is the intersection of all hypersurfaces defined in equation (3). Assuming that the life cycle impact functions are monotonic as a function of design parameters, a specific design space emerges that is defined by all impacts



being less than the threshold or baseline that results from solving and graphing the equation based on the chosen target life cycle impact values.

To illustrate the method, consider the case of two life cycle impact types, two design parameters, and three operating condition types ( $l = 2$ ,  $n = 2$ ,  $m = 3$ ). For the sake of illustration, assume that the life cycle impact functions are linear. Figure 4 shows hypothetical results for  $LC\_impact_1$  in the two-dimensional design space. Assuming that  $LC\_impact_1 < T_1$  for all spaces to the right of the lines, the design space that meets  $T_1$  under all operating conditions is shown by the cross-hatched lines.

Figure 5 shows hypothetical results for the second impact category, with the favorable design space again denoted by cross-hatched lines. Note that for  $LC\_impact_2$ , operating condition 2 solely constrains the design space. The design space that meets both target life cycle impacts,  $T_1$  and  $T_2$ , is defined by the intersection of the two spaces in figures 4 and 5, shown in figure 6. Note that for part of the design space in figure 6, operating condition 3 from  $LC\_impact_1$  is constraining but elsewhere the design space is determined by operating condition 2 from  $LC\_impact_2$ .

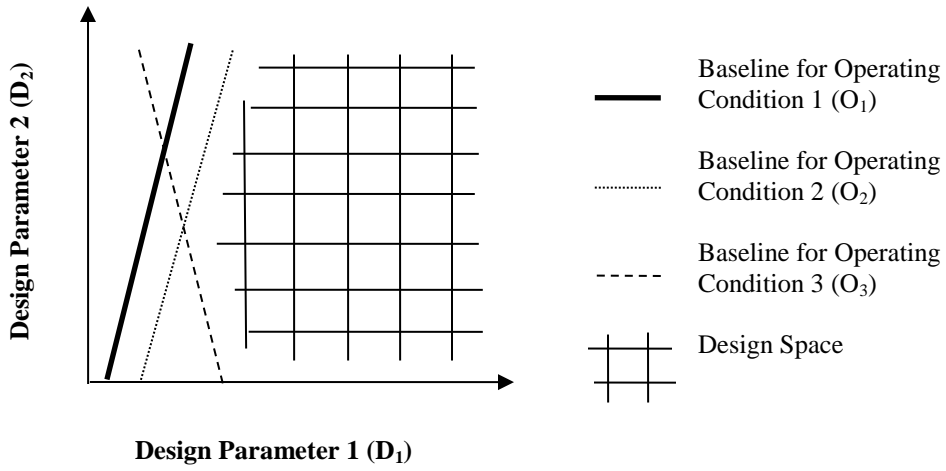

**Figure 4** Hypothetical results for a two-dimensional design space meeting first target life cycle impact:  $LC\_impact_1(D_1, D_2; O_{1,2,3}) = T_1$ .

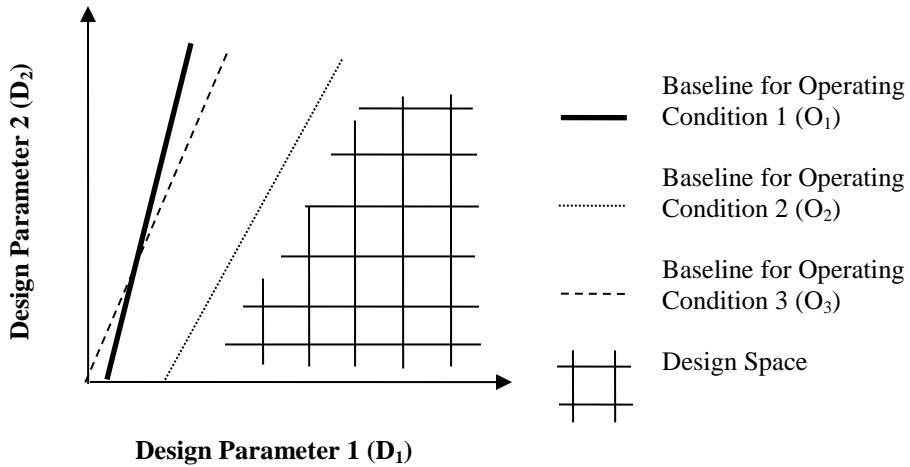

**Figure 5** Hypothetical results for a two-dimensional design space meeting second target life cycle impact:  $LC\_impact_2(D_1, D_2; O_{1,2,3}) = T_2$ .

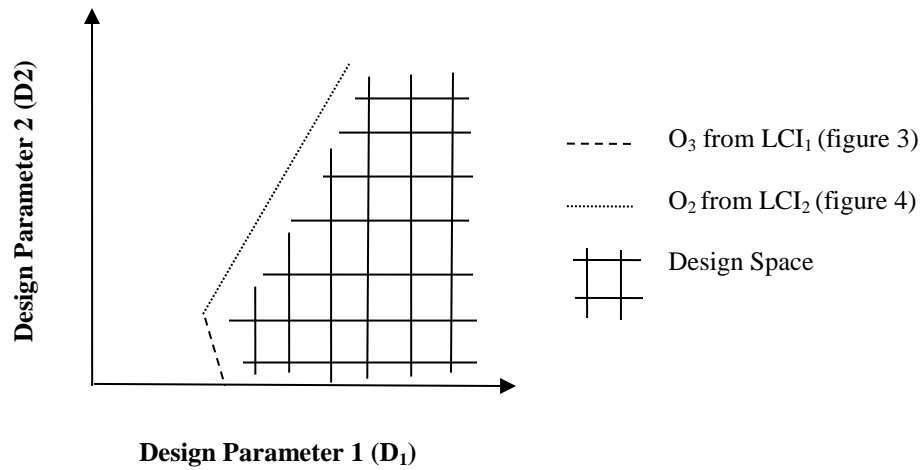

**Figure 6** The design space that meets both target life cycle impacts under all operating conditions.

### **Case Study of Design Constraints to Realize Life Cycle Economic and Carbon Dioxide Reduction Benefits**

We next apply the DfE methodology developed in the previous section to smart irrigation controllers in residential settings in the southwestern United States, where smart irrigation controllers have the potential to make positive economic and environmental impact. In this study we do not explore the particulars of how to design better controllers for the Southwest; our focus instead is to clarify the design goals that smart irrigation controllers must meet. To expand on the motivation, it is not clear from the review of studies of smart irrigation controllers how the manufacturer design goal of applying only enough water to match local landscape ET rates compares with controller brands/strategy

in the same location, or when a brand/strategy is moved geographically. It also seems that the advertised goal of water savings by manufacturers and utilities depends on many different variables, including the climate of the location, type of landscape, previous water application rate, self or professional installation and maintenance, and proper installation and maintenance of the sprinkler system. Further work is needed to understand how to design smart irrigation controllers and adoption programs to realize maximum economic and environmental benefits of the technology. Higher economic benefits in particular ease the promotion of any technology and, indeed, if benefits are sufficiently high, market forces alone can lead to widespread diffusion.

One impact to consider is economic; at the very least a smart irrigation controller should generate an economic life cycle impact benefit for consumers. A second impact to consider is related to carbon dioxide impact.<sup>3</sup> Though the ostensible purpose of an irrigation controller is to save water, it is preferable that these water savings do not induce negative environmental externalities such as increased energy use or carbon emissions. Given that smart irrigation controllers require both additional energy to produce, and consume more electricity to use as compared with a conventional controller, it is worth ensuring that energy and thus carbon dioxide savings embodied in the water savings exceed the additional energy investment and carbon dioxide emissions in controllers. Many other important goals exist, such as ease of set up, use, and maintenance. In this study we only consider the design goals that irrigation controllers must meet so as to realize net economic and carbon benefits.

We therefore construct models of life cycle economic and carbon characteristics of smart irrigation controllers in residential settings. One key issue to consider is that the design goals to realize net economic and carbon emission benefits will change depending on where the controller is used. Water and electricity prices affect the life cycle impact and vary significantly in different areas in the Southwest. The carbon dioxide embodied in electricity and water also varies. We therefore construct a model accounting for geographical variability with two goals in mind. One goal is to identify if there are certain areas in the Southwest that appear particularly attractive for early adoption of controllers. A second goal is to work toward long-term design goals for a controller that will realize benefits wherever it is used in the Southwest. Realizing inexpensive controllers will require mass-produced standardized designs, therefore, a controller that will work anywhere can achieve better economies of scale.

*Economic Analysis—Consumer Impact*

In this section we find the price and water savings characteristics a controller must meet in order to realize net economic benefits for a resident in different southwestern cities:

$$LC\_impact_1(D_1, D_2; O_{1-6}) = 0, \tag{4}$$

where  $LC\_impact_1$  refers to economic performance over the life cycle of the controller;  $D_1$  is the percent outdoor water savings of the controller;  $D_2$  is the annual cost of controller;  $O_1$  is the operating condition for Tucson, Arizona;  $O_2$  is the operating condition for Phoenix, Arizona;  $O_3$  is the operating condition for

Las Vegas, Nevada;  $O_4$  is the operating condition for San Diego, California;  $O_5$  is the operating condition for Los Angeles, California; and  $O_6$  is the operating condition for Riverside, California.

The life cycle impact equation we used takes into consideration the cost of the controller, the money saved on a water bill due to a water savings, and the extra electricity cost to run a smart irrigation controller. In addition, the economic analysis takes into consideration net present value of a smart irrigation controller with an assumed ten-year lifespan (Mayer et al. 2009). To conform to our conventions, we specifically use net present cost:

$$\begin{aligned}
 LC\_impact_1 &= \text{Smart Irrigation Controller Price} - \text{Water Bill Savings} + \\
 &\quad \text{Additional Electricity Cost (adjusted for net present cost)} \\
 &= D_1 + \sum_{t=1}^N \frac{(-K_1 K_2 K_3 D_2) + (K_4 - K_5)(K_6)}{(1+r)^t} \\
 &= 0, \tag{5}
 \end{aligned}$$

where  $D_1$  is the retail cost of the smart irrigation controller, including the yearly service fees that some companies charge;  $N$  is the lifetime of the controller;  $r$  is the discount rate;  $K_1$  is the average water rate as of April 2010 (only charges based on consumption are included);  $K_2$  is the average household water consumption per year;  $K_3$  is the average fraction of that water demand for outdoor uses;  $D_2$  is the fraction of outdoor water that is saved by a smart irrigation controller;  $K_4$  is the yearly electricity required to run a smart irrigation controller;  $K_5$  is the yearly electricity required to run a traditional irrigation controller; and  $K_6$  is the average cost of electricity in 2008 (total electric industry). The constants,

$K$ , represent the parameters for an operating condition (see tables 3 and 4). We solved for  $D_1$  and graphed the baseline for each city (figure 7).

### *Carbon Dioxide Analysis—Global Impact*

Our goal for life cycle carbon is for the smart irrigation controller to be, at the very least, carbon neutral; the additional carbon dioxide emitted in manufacture and electricity generation for use by the controller must at least be balanced by the carbon dioxide reductions from reduced water use. The impact function takes the form:

$$LC\_impact_2 (D_1, D_2; O_{1-6}) = 0, \quad (6)$$

where  $LC\_impact_2$  refers to carbon dioxide emission over the life cycle of the controller and the other variables are the same as in equation (4).

The carbon life cycle impact equation we used takes into consideration the manufacturing process, the carbon dioxide emitted from the generation of extra electricity needed to run a smart irrigation controller compared with a traditional controller, and the carbon dioxide emissions avoided due to the decreased need to transport and treat drinking water for landscaping:

$$\begin{aligned} LC\_impact_2 &= \text{Smart Irrigation Controller Manufacturing Emissions} + \\ &\text{Differential Electricity Use Emissions (compared to conventional} \\ &\text{controller)} - \text{Emissions from avoided water use} \\ &= (K_7 C_1 C_2 D_1 + (K_4 - K_5) K_8 - K_2 K_3 K_8 K_9 D_2)(N) = 0, \end{aligned} \quad (7)$$

where  $K_7$  is the kilograms of carbon dioxide emitted per 2002 producer dollar of manufacturing in the U.S. small electrical appliance manufacturing sector

(NAICS #33521, 335211, and 335212),  $C_1$  is the 2004 producer price to 2007 producer price ratio (2002 data were not available),  $C_2$  is the 2002 producer price to 2002 consumer price ratio (2007 data were not available),  $K_8$  is the average kilograms (kg)<sup>4</sup> of carbon dioxide emitted per kilowatt-hour of electricity produced from 1998 to 2000, and  $K_9$  is the kilowatt-hours required to treat and transport one liter (L)<sup>5</sup> of drinking water. The other constants and variables are the same as in equation (5). The constants,  $K$ , represent the parameters for an operating condition (see tables 3 and 4).  $C_1$  and  $C_2$  convert the 2002 producer price used in  $K_7$  to a 2007 consumer price, so that both  $LC\_impact1$  and  $LC\_impact2$  are based on the 2007 consumer prices that are used in table 5. We solved for  $D_1$  and graphed the baseline for each city (figure 8).

### *Data*

Data for the smart irrigation controller case study can be found in below. This includes the values for constants and variables in equations 5 and 7 (see tables 3 and 4). It also includes information about six smart irrigation controller studies conducted by various entities (see table 5). The information in table 5 was used in figures 9 and 10.



**Table 3** Data for the economic and carbon dioxide analyses that are operating condition independent (same for each city).

	<b>Data</b>	<b>Citation</b>
<b>r – Discount Rate (%)</b>	10	Hausman 1979; Howarth and Sanstad 1995; U.S. Department of Energy 2007, 2009
<b>N – Assumed Lifetime of Controller (yrs)</b>	10	Mayer et al. 2009
<b>K<sub>4</sub> – Average Electricity Use of Smart Irrigation Controller (kWh/yr)</b>	37	Brown 2009
<b>K<sub>5</sub> – Average Electricity Use of Traditional Controller (kWh/yr)</b>	18	Brown 2009
<b>K<sub>7</sub> – CO<sub>2</sub> Emitted for Manufacturing (kg/\$)</b>	0.57	Carnegie Mellon University 2010
<b>C<sub>1</sub> – 2004 Producer Price to 2007 Producer Price Ratio</b>	0.95	U.S. Bureau of Labor Statistics 2010
<b>C<sub>2</sub> – 2002 Producer Price to 2002 Consumer Price Ratio</b>	0.63	U.S. Bureau of Economic Analysis 2010

**Table 4** Data for the economic and carbon dioxide analyses that are operating condition dependent (different for each city).

	<b>O<sub>1</sub> – Tucson, AZ</b>	<b>O<sub>2</sub> – Phoenix, AZ</b>	<b>O<sub>3</sub> – Las Vegas, NV</b>	<b>O<sub>4</sub> – San Diego, CA</b>	<b>O<sub>5</sub> – Los Angeles, CA</b>	<b>O<sub>6</sub> – Riverside, CA</b>
<b>K<sub>1</sub> – Cost of Water (¢/L)</b>	0.135 <sup>A</sup>	0.106 <sup>B</sup>	0.086 <sup>C</sup>	0.116 <sup>D</sup>	0.105 <sup>E</sup>	0.037 <sup>F</sup>
<b>K<sub>2</sub> – Average Total Household Water Consumption (L/yr)</b>	398,000 <sup>G</sup>	627,000 <sup>H</sup>	470,000 <sup>I</sup>	476,000 <sup>J</sup>	207,000 <sup>K</sup>	522,000 <sup>K</sup>
<b>K<sub>3</sub> – Average Outdoor Water Demand (%)</b>	60 <sup>L</sup>	74 <sup>H</sup>	70 <sup>M</sup>	60 <sup>N</sup>	70 <sup>O</sup>	70 <sup>O</sup>
<b>K<sub>6</sub> – Average Cost of Electricity (\$/kWh)</b>	0.103 <sup>P</sup>	0.103 <sup>P</sup>	0.119 <sup>P</sup>	0.138 <sup>P</sup>	0.138 <sup>P</sup>	0.138 <sup>P</sup>
<b>K<sub>8</sub> – CO<sub>2</sub> Emitted for Electricity (kg/kWh)</b>	0.476 <sup>Q</sup>	0.476 <sup>Q</sup>	0.689 <sup>Q</sup>	0.277 <sup>Q</sup>	0.277 <sup>Q</sup>	0.277 <sup>Q</sup>
<b>K<sub>9</sub> – Energy to Treat and Transport Water (kWh/L)</b>	0.0017 <sup>R</sup>	0.0017 <sup>R</sup>	0.0016 <sup>S</sup>	0.0020 <sup>T</sup>	0.0024 <sup>T</sup>	0.0021 <sup>T</sup>

<sup>A</sup>City of Tucson Water Department 2005, 2009; Pima County 2010

<sup>B</sup>City of Phoenix Water Services Department 2010; Brown 2003

- <sup>C</sup>Las Vegas Valley Water District 2010
- <sup>D</sup>The City of San Diego Public Utilities: Water 2010a
- <sup>E</sup>Los Angeles Department of Water and Power 2010
- <sup>F</sup>City of Riverside Public Utilities Department 2009
- <sup>G</sup>City of Tucson Water Department 2005
- <sup>H</sup>Wentz and Gober 2007
- <sup>I</sup>Sweet 2008
- <sup>J</sup>The City of San Diego Public Utilities: Water 2010b
- <sup>K</sup>Riverside County Task Force 2008
- <sup>L</sup>Modeer 2006
- <sup>M</sup>Devitt et al. 2008
- <sup>N</sup>Barbarella 2007
- <sup>O</sup>Los Angeles County of Public Works 2010
- <sup>P</sup>U.S. Energy Information Administration 2010
- <sup>Q</sup>U.S. Department of Energy 2002
- <sup>R</sup>Hallin and Holton 2008
- <sup>S</sup>Las Vegas Sun 2010
- <sup>T</sup>Cohen et al. 2004

**Table 5** Summary of some individual studies on smart irrigation controllers in residential settings using volunteer participants.

	<b>Study 1</b>	<b>Study 2</b>	<b>Study 3</b>	<b>Study 4</b>	<b>Study 5</b>	<b>Study 6</b>
<b>Location</b>	Tucson, AZ	Tucson, AZ	Las Vegas, NV	Foothill Municipal Water District, CA	Glendale Water & Power, CA	Inland Empire Utilities Agency, CA
<b>Brand</b>	Hydpoint	WeatherMiser	Hydpoint	Weathermatic	Weathermatic	Accurate WeatherSet
<b>Smart Irrigation Controller Strategy</b>	Off-site weather stations and satellite-based communication	On-site temperature and humidity sensors	Off-site weather stations and satellite-based communication	On-site temperature sensor and location-based historical solar radiation	On-site temperature sensor and location-based historical solar radiation	On-site solar and rain sensors
<b>Average Outdoor Water Savings (%)</b>	25	3.2	20	10	18	42
<b>Total 2007, Retail Price of Controller (\$) (USBR 2007)</b>	449 plus 48 per year	130	449 plus 48 per year	300	300	220
<b>Number of Sites</b>	≤27	≤27	17	244	109	185
<b>Installation Type</b>	Professional	Professional	Study Researcher	User	User	User
<b>Citation</b>	U.S. Bureau of Reclamation 2008	U.S. Bureau of Reclamation 2008	Devitt et al. 2008	Mayer et al. 2009	Mayer et al. 2009	Mayer et al. 2009

## *Main Results*

Figures 7 and 8 show baselines for the economic and carbon dioxide life cycle impacts of residential smart irrigation controllers for different cities in the Southwest. Data points to the right of and below a line reflect economic or carbon dioxide savings, and data points to the left of and above a line represent net economic costs or carbon dioxide emissions. Figures 7 and 8 demonstrate that there is variability in the economic conditions and life cycle carbon emissions resulting from smart irrigation controllers in different parts of the Southwest. Phoenix has favorable economic conditions for smart irrigation controllers because of higher water rates based on consumption and higher outdoor water use (high total consumption and outdoor consumption). Riverside, on the other hand, faces more severe economic constraints because water rates are based less on consumption and more on a flat fee. With regard to carbon dioxide emissions, higher water consumption made Phoenix, San Diego, and Riverside the best places to implement smart irrigation controllers because higher water consumption means more potential for water savings. Los Angeles came out on the bottom due to low water consumption. Comparing figures 7 and 8, we also see that smart irrigation controllers may have a slightly greater carbon dioxide benefit than an economic benefit because the slope of the baselines in figure 8 are steeper than in figure 7.

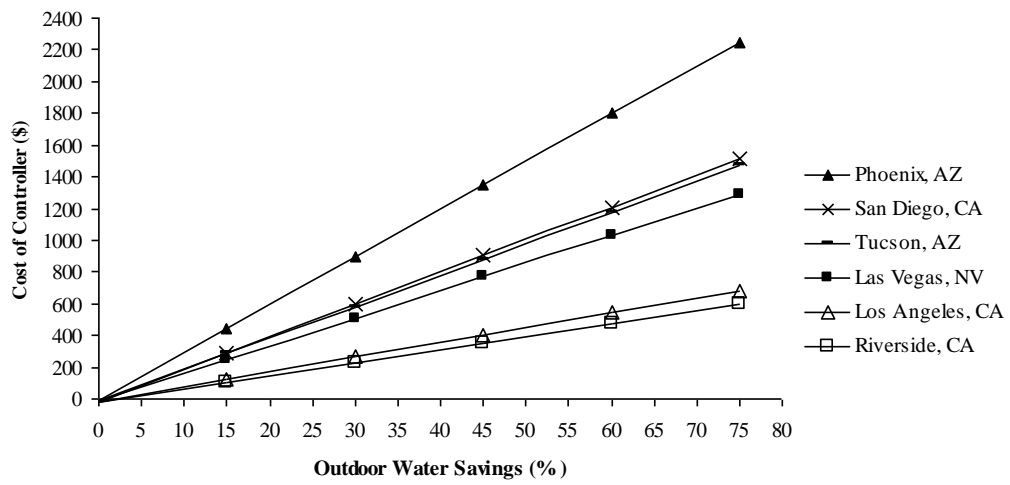

**Figure 7** Baselines representing a life cycle cost of zero for residential smart irrigation controllers in different cities in the Southwest. The cost of the controller is the retail cost, plus ten years of service fees for brands that charge annual service fees.

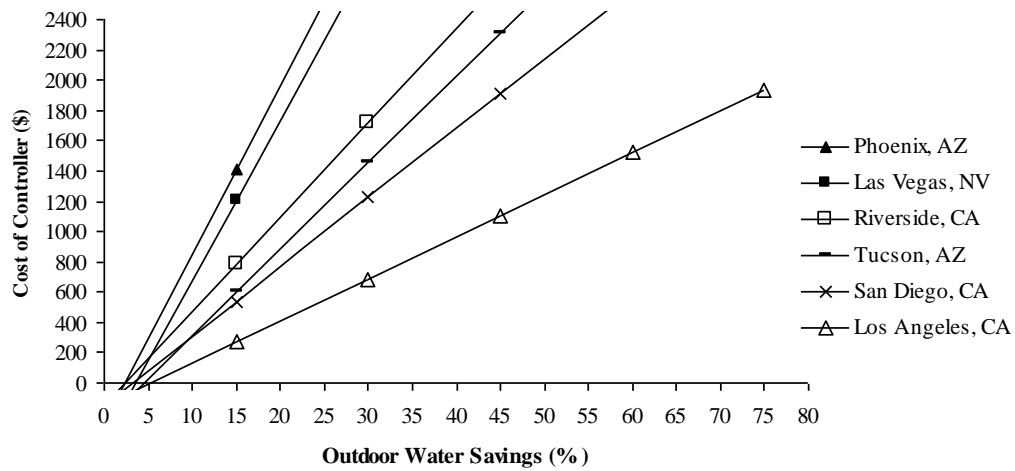

**Figure 8** Baselines representing a carbon dioxide life cycle emissions of zero for residential smart irrigation controller in different cities in the Southwest. The cost of the controller is the retail cost, plus ten years of service fees for brands that charge annual service fees.

In figure 9 we plotted the two least favorable conditions for economics and carbon dioxide emissions. We can see what controller price and water savings manufacturers might want to strive for in their products. The area to the right of and below the Riverside economic baseline is effectively the design space because there is little overlap between the two baselines. This space is the template for producing a controller that is both economical and carbon neutral in all cities studied. We also plotted the six studies described in table 5 on the same graph. Comparing individual studies against the two least favorable conditions, only Study 6 (Inland Empire) is within the range of both economic and carbon

dioxide savings. Study 5 (Glendale) is in the range of carbon dioxide savings, but not economic savings. Studies 1 through 4 (Tucson, Las Vegas, and Foothill) are out of range of both types of savings. Although we cannot say whether the results of these studies would be the same when moved geographically, they at least give an idea of how smart irrigation controllers might be falling short of realizing their maximum environmental and economic benefit over the region of the Southwest. Alternatively, changes in other variables such as water pricing and amount of energy to treat and deliver water may also change the position of the baselines and thus the economic ability or sustainability of smart irrigation controllers.

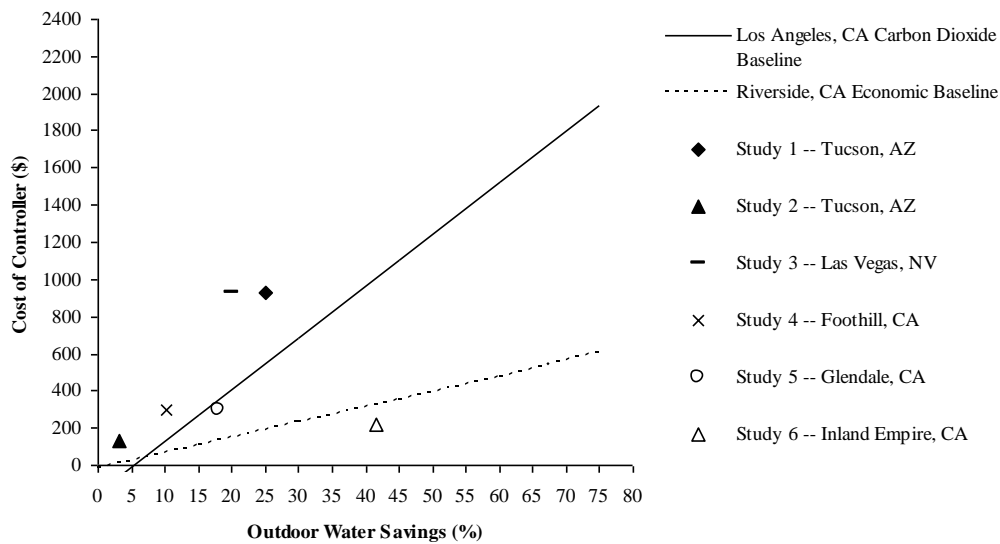

**Figure 9** The results of six smart irrigation controller studies compared with the least favorable economic and carbon dioxide conditions from figures 7 and 8. The cost of the controller is the retail cost, plus ten years of service fees for brands that charge annual service fees.



Another perspective can come from focusing on one area in order to assess how water savings and controller price, under the given local operating condition, compare with the life cycle impact targets. Figure 10 shows sample results for Tucson; other areas are shown in the supporting information. In Tucson, controllers on the borderline of failing one or the other life cycle impact targets indicate a need for improved designs.

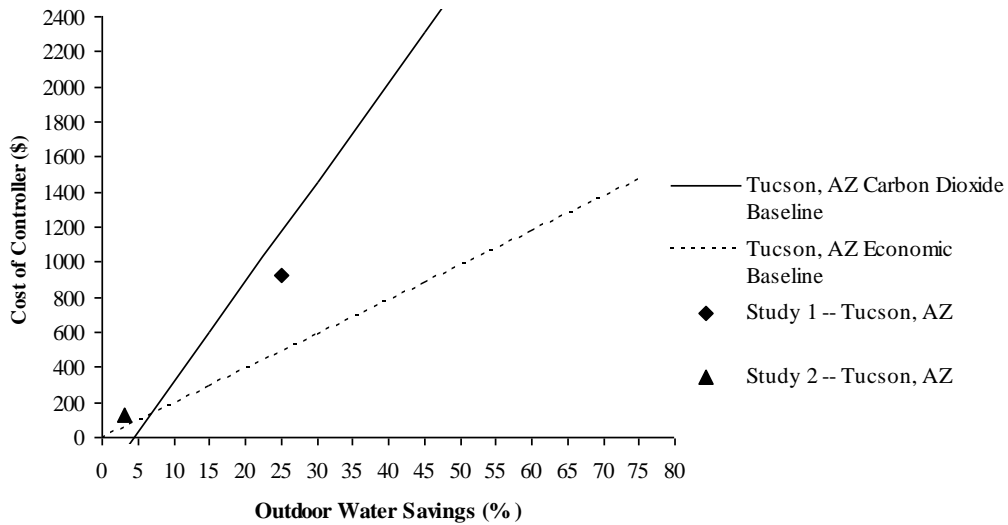

**Figure 10** The Tucson economic and carbon dioxide baselines compared with Tucson empirical results. The cost of the controller is the retail cost, plus ten years of service fees for brands that charge annual service fees.

*Additional Results*

Sensitivity Analysis

For the smart irrigation controller case study, we used average water consumption data. The standard deviation from the average can be high, however.

Figures 11 and 12 illustrate what happens to the baselines when minimum and maximum household water consumption is considered. Figures 11 and 12 show that the maximum water users in Phoenix have the potential to benefit much more from smart irrigation controllers than the minimum water users in Phoenix.

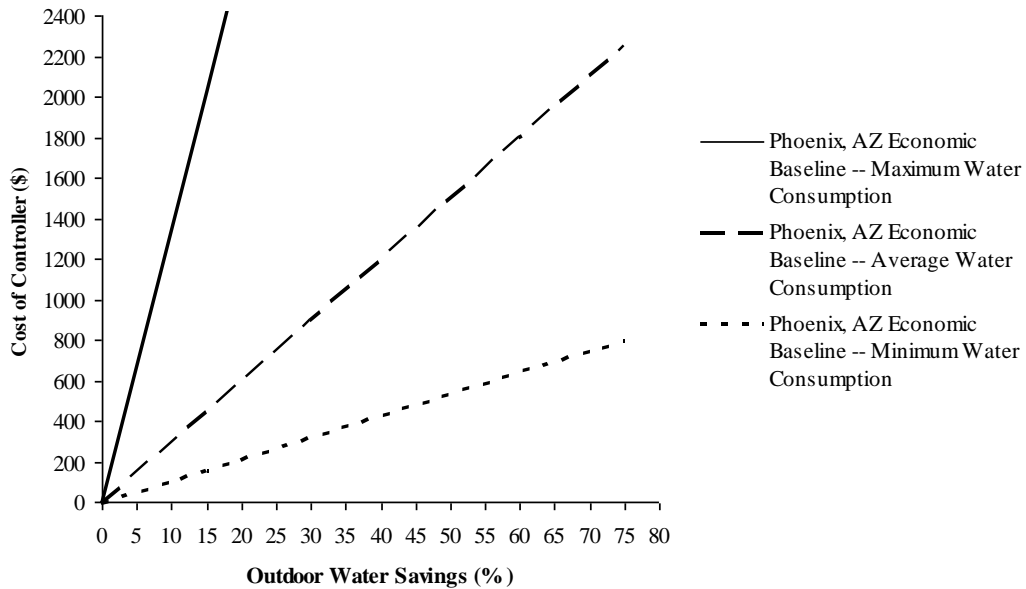

**Figure 11** Economic baselines for minimum, average, and maximum household water consumption in Phoenix, AZ. The cost of the controller is the retail cost, plus ten years of service fees for brands that charge annual service fees.

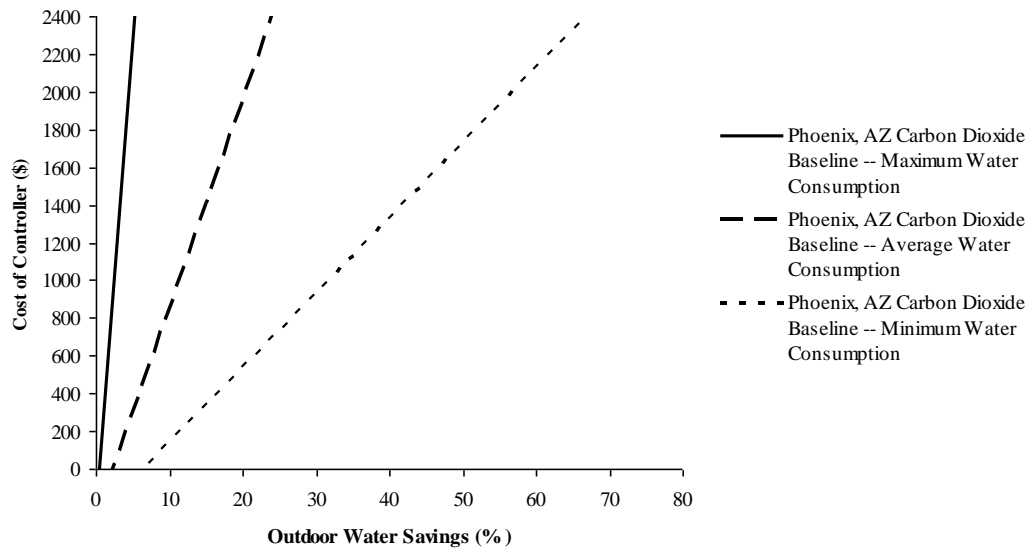
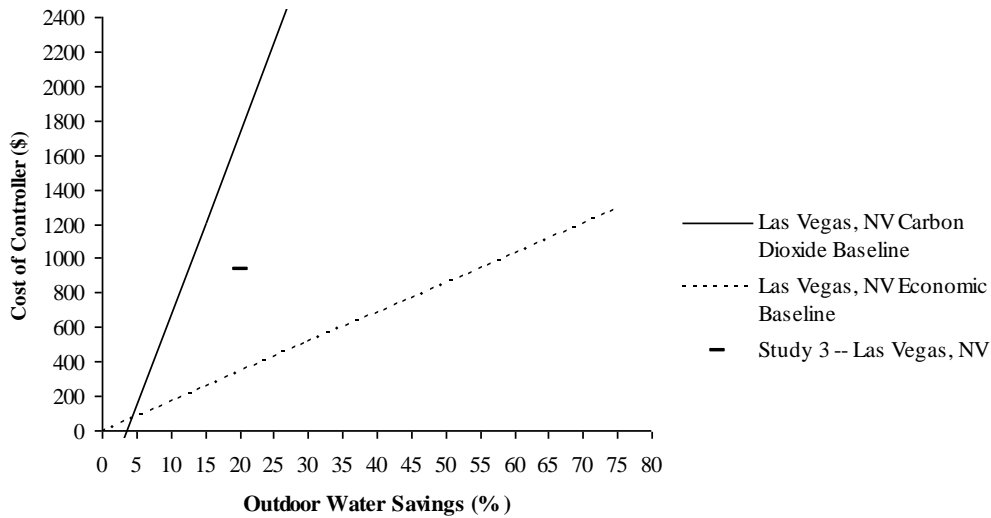

**Figure 12** Carbon dioxide baselines for minimum, average, and maximum household water consumption in Phoenix, AZ. The cost of the controller is the retail cost, plus ten years of service fees for brands that charge annual service fees.

Additional Area-to-Area results

Figures 14 through 16 are additional area-to-area smart irrigation controller performance analyses, similar to figure 10. It includes Las Vegas and the Greater Los Angeles Area (GLAA). Looking at the figures, Las Vegas and Glendale do not seem to have the right combination of economic conditions and smart irrigation controller performance to warrant the use of the technology in an average household, at least when referring to the brand that was tested. The brand tested in Inland Empire does, however, seem to have adequate economic conditions for the performance of the controller in that area. Interestingly, the results for the two GLAA studies/baselines (figures 14 and 15) were quite

different even though their central locations are only about 50 miles apart. Even though the results show that most controllers cost more to the consumer than they would save on their utility bills, the results do show a positive environmental benefit of reduced carbon dioxide emissions (Studies 3, 5, and 6).



**Figure 13** The Las Vegas economic and carbon dioxide baselines compared to Las Vegas empirical results. The cost of the controller is the retail cost, plus ten years of service fees for brands that charge annual service fees.

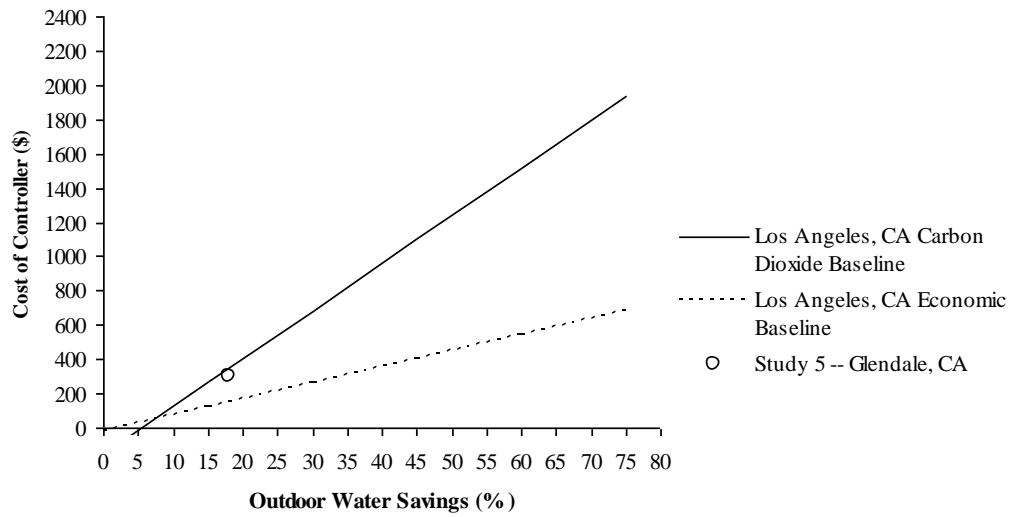

**Figure 14** The Los Angeles economic and carbon dioxide baselines compared to Glendale empirical results. The cost of the controller is the retail cost, plus ten years of service fees for brands that charge annual service fees.

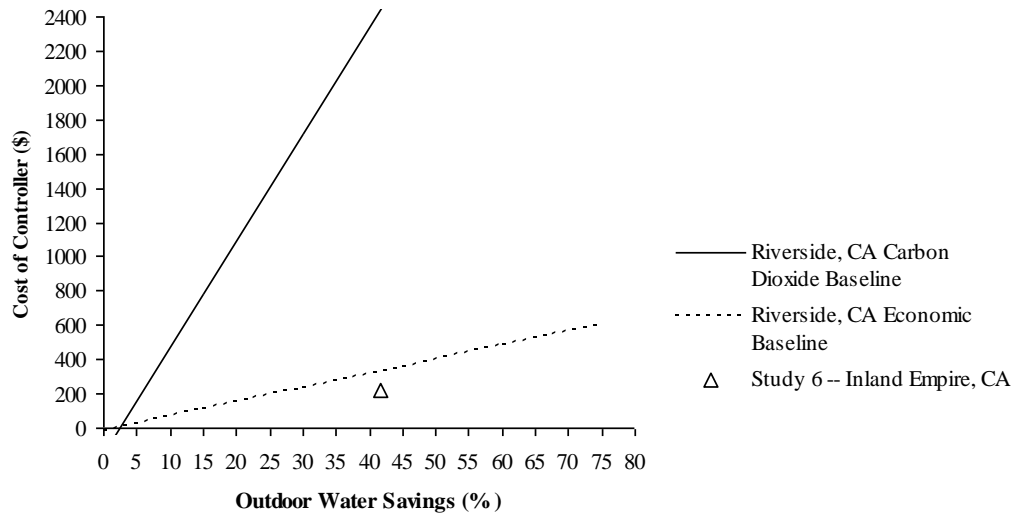

**Figure 15** The Riverside economic and carbon dioxide baselines compared to Inland Empire empirical results. The cost of the controller is the retail cost, plus ten years of service fees for brands that charge annual service fees.

Additional Energy Analysis

Figure 16 is another LC\_impact function (LC\_impact<sub>3</sub>) that could be included in the analysis. It is the energy analysis. It is similar to the carbon dioxide analysis, but the resulting baselines are slightly different. The equation for this analysis is as follows:

$$\begin{aligned}
 & \text{LC\_impact}_3 = \text{Smart Irrigation Controller Manufacturing Energy} \\
 & \text{Consumption} + \text{Differential Electricity Use (compared to conventional} \\
 & \text{controller)} - \text{Energy from avoided water use} \\
 & = (K_{10}C_1C_2D_1 + K_4 - K_5 - K_2K_3K_9D_2)(N), \tag{8}
 \end{aligned}$$

where  $K_{10}$  is 2.55 kWh/\$, the energy consumed per 2002 producer dollar of manufacturing in U.S. NAICS sector #33521, 335211, and 335212: Small

Electrical Appliance Manufacturing (Carnegie Mellon University 2010), and the other constants and variables are the same as in equations (5) and (7).

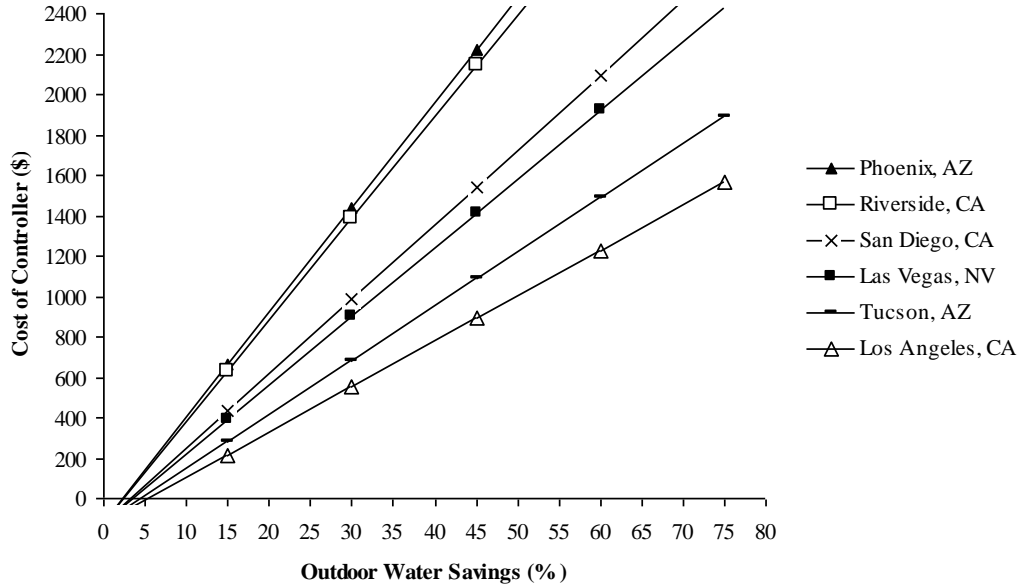

**Figure 16** Energy life cycle impact = 0 for residential smart irrigation controllers in different cities in the Southwest. The cost of the controller is the retail cost, plus ten years of service fees for brands that charge annual service fees.

*Assumptions, Uncertainties, and Additional Information*

Equations

Equations (5) and (7) consider the lifetime of the smart irrigation controller, which means that many of the constants,  $K$ , may change over time. The application of net present cost in equation (5) is the only alteration that takes this into consideration. We assume in our calculations that prices of water and electricity as well as consumption patterns will stay relatively static over time. We also did not include the yearly service fee of a smart irrigation controller in the net

present cost adjustment, because it would have added another variable to our equation, making the graph three dimensional. The ten years of services fees, instead, became part of the upfront cost of a smart irrigation controller.

#### Tables 3 and 4

The discount rate was chosen based on a literature review about discount rates pertaining to the purchase of energy efficient technology. The research indicates that discount rates for purchasing and installing energy efficient technology are high (greater than 10%), due to the perceived risk involved in making money back on the purchase (Hausman 1979; Howarth and Sanstad 1995). The U.S. federal government, however, uses a lower discount rate (3.3% and 4.8%) in their calculations concerning energy efficient technologies (U.S. Department of Energy 2007, 2009). We therefore took the middle ground by choosing a discount rate of 10%.

Drinking water prices are billed monthly and are often tiered or seasonal. Our most accurate water prices come from Phoenix and Tucson, where we had data that showed monthly average water consumption or seasonal water use variation. Even though landscape water is not part of the wastewater cycle, sewer rates are also included in the calculation when the rates are based on drinking water consumption. Some cities include sewer rates in their drinking water prices, while others charge them separately. San Diego, Los Angeles, and Phoenix do include sewer in their drinking water rates; Tucson, Las Vegas, and Riverside do not. In Las Vegas and Riverside, sewer charges are a flat rate not based on consumption, so saving water does not improve a consumer's bill (Clark County



Water Reclamation District 2010; City of Riverside Public Works Department 2010). In Tucson, sewer rates are based on consumption, so the sewer rate was added to the drinking water rate (Pima County 2010).

For water consumption, the source for Phoenix and Tucson specifically looked at single-family homes, though it is assumed that the other sources looked at all housing types. Single-family home consumption values are assumed to be higher than the average of all housing types.

For outdoor water demand, we often found multiple references with a variation in percentages. We chose sources that we believed to be the most reliable rather than averaging multiple values. Also, we chose to use outdoor water use percentages which include other outdoor uses (pools, car washing) instead of just landscape water use specifically, because data on landscape-specific consumption was not found for all locations.

Electricity usage was based on one study by Brown (2009), but only 11 regular controllers and 8 smart controllers were tested, so the average electricity use is only based on small sample. To find the yearly electrical usage, we multiplied the standby energy found by Brown (2009) to the number of hours in a year. The amount of electricity used when the unit was actually running (not on standby) was not found to be significant compared to the standby electricity usage. This is partly because the amount of time that the system is actually running is much smaller than the amount of time it is on standby.

The cost of electricity and the carbon dioxide per kilowatt of energy produced was an average per state value. A more complete study would have

more localized data. In addition, kilograms of carbon dioxide emitted during manufacturing was based on the Carnegie Mellon University online economic input-output LCA tool for the sector of small electric appliance manufacture, year 2002 (Carnegie Mellon University 2010). A more complete manufacturing impact analysis would need to look deeper into this sector and others to determine the best representation of the smart irrigation controller product. Also, we assume, using this tool, that the greater the price of the controller, the greater the carbon impact in this sector.

We used 2007 consumer price data, but the Carnegie Mellon University online tool mentioned above gives the kilograms of carbon dioxide per 2002 producer price. We wanted to convert the 2002 producer price to 2007 consumer price by first converting the 2002 producer price to 2007 producer price and then converting the 2007 producer price to 2007 consumer price, but could not do it precisely because the data for the years we needed were not available. We did not have 2002 producer price data, so we used 2004 producer price data instead. We also did not have 2007 consumer price data, so we used 2002 consumer price data. The 2004 producer price and 2002 consumer price data we used were the closest available to the years we needed.

Lastly, the information we needed for the total energy required to treat and transport water was not found for each city. We found information for the Phoenix area, so we decided to use the same data for Tucson. We suspect that the impact for Tucson is greater, however, because the greater distance required to transport Central Arizona Project water. For California, we found information for

San Diego, Northern Los Angeles Basin, and Southern Los Angeles basin. We chose to average both the Los Angeles Basin values for Los Angeles and use the Northern Los Angeles Basin values for Riverside (Cohen, et al. 2004). Also related to energy to treat water, we used data that only included the cycle up to the delivery of water to the home; we did not want to include the wastewater treatment cycle, because landscape water is not part of this cycle.

#### Table 5

In the article by the Bureau of Reclamation (2007), a range of prices is given for each manufacturer. Generally, the price increases as the size of the landscape increases (number of stations). The lowest price was chosen, because most residential applications only require four to six stations. The plus \$48 per year for the Hydropoint controller is the yearly service fee.

Study 1 and Study 2 were taken from an article by Quandrud and France (U.S. Bureau of Reclamation 2008). A total of 27 sites were part of the study, but we did not find out if both controllers were installed at each site or if the sites were split between controller brands.

It also should be noted that the Study 6 includes one Weathermatic brand controller in the results. This means that the total number of sites is actually 186, and the result of the study is somewhat influenced by the Weathermatic controller.

## **Implications**

What do these results imply for future efforts to improve smart irrigation controllers? One conclusion is that there is clearly a need to lower prices and increase water savings to make smart irrigation controllers broadly attractive to consumers in the Southwest. Partly, these are design issues, but design issues also interface with systems aspects. Price is related to economies of scale. Like many new technology products, smart irrigation controllers face a “chicken and egg” dilemma: at the beginning they are expensive, which limits demand, but without demand, economies of scale do not come into play to reduce the price. A niche market structure is often the solution to this dilemma; even when the product is expensive, there is an initial set of consumers willing to pay. Purchases from this niche support building capacity to bring the price down low enough to be attractive to the next niche, and so on. In the case of smart irrigation controllers, it is not clear whether there is a viable path through niche markets. This analysis suggests that geographical area is one way to conceptualize the niche markets: at the beginning, focus on areas such as Phoenix, where the product delivers higher benefits, and use experiences and capacity in these areas to improve the product in order to become viable in other areas. More work is needed to determine an effective niche strategy.

Increasing water savings are also needed. One layer of this challenge is choice of technology. Prior experience indicates that the ET tracking method results in the higher water savings throughout the Southwest. Work should be done to determine the robustness of this result, and if true, the technology could

be standardized in order to reduce costs and increase average water savings. Another consideration is variability in operating conditions at the individual level. Wide variations in water savings, from considerable savings to increased water use, suggest that there is a substantial learning curve ahead in terms of how and when to implement the technology. Interfaces exist between controller design, landscape type, climate, and user behavior that significantly affect the performance of smart irrigation controllers. Research and development are needed to understand these better in order to optimize controller design and implementation programs. Given the potential social benefits of the technology, increased public investment should be considered.

It should also be determined if there are geographic areas that are not economically or environmentally suitable for smart irrigation controllers. If there are such regions, it should be determined if there are conditions that can change in order to make them more viable. The method presented may be able to indicate this. Lastly, it is worth noting that although this study focuses on the controller, the controller plays a role in a larger suite of options to reduce municipal landscape water use such as sprinkler system design and maintenance, low-water landscaping, and gray water reuse. Work is also needed to develop effective strategies that combine appropriate and effective options.

## Chapter 4

### CONCLUSION

Smart water grid has the potential to save wasted water, save energy, improve water quality detection, and improve water infrastructure resiliency. Some utilities and consumers are installing smart water technology, but little systems-level research or implementation of smart water grid exists. Two reasons that smart water grid might not be being realized in the United States include an institutionalized culture within the utilities of focusing on providing a low-cost, invisible service to consumers, and lack of funding for advanced technology because funding is needed to just bring basic infrastructure up to date. Additional challenges to smart water grid implementation include difficulty in increasing water prices to pay for the initial capital costs, divided benefits between those paying for smart water grid and those benefiting from it, and community opposition to smart technology due to fears about privacy and radiation.

Some solutions to overcoming some of these barriers include focusing on the future return on investment from implementing smart water grid, government research and development funding, and government regulation. Future research on smart water grid could benefit from more public cost benefit analyses showing how much money smart water grid could save over a long period of time; systems-level research, rather than just research focusing on individual technologies; and advances in specific technologies, such as smart irrigation controllers and contaminant sensors.

The second part of this thesis sought to begin to fill these research gaps by conducting an analysis of the environmental and financial benefits of smart irrigation controllers. In the process, a general design for environment (DfE) method was created that can be used for other smart technologies or other products not related to smart water grid. This DfE method allows for multi-attribute design of products by considering multiple life cycle impacts at one time. It also allows for known product performance variations related to design attributes.

For smart irrigation controllers, there is a research gap on their effectiveness at saving water, as well as their ability to pay for themselves with those water savings. Using the DfE method, two life cycle impacts were chosen: carbon dioxide impact as the indicator for the environmental benefit of saving water, and economic life cycle impact from the savings to the consumer over the lifetime of the product from water savings. Product performance variations were introduced by analyzing the impacts in different southwestern U.S. cities. It was found that some cities, such as Phoenix, Arizona, are much easier to design for than others. It was also found that many controllers would likely fall short of realizing environmental and economic benefits in most of the cities analyzed. As a result, it was suggested that the technology be standardized in order to provide benefit at more locations, and that initial roll-out efforts be concentrated in cities like Phoenix, where environmental and economic benefits are more likely to be realized.

Smart water grid development is in line with the direction modern society is going in general – computerization and automation of previously manually implemented tasks. There are many general questions and issues concerning the implications of moving towards using more Information and communication technology (ICT) in society. Like any emerging technological system, smart water grid comes with its own specific structure, benefits, drawbacks, and challenges within the ICT realm. These specifics have been explored in this thesis, with the hope of informing the direction of future research and thinking in the area of smart water grid.



## NOTES

1. One kilowatt-hour (kWh)  $\approx 3.6 \times 10^6$  joules (J, SI)  $\approx 3.412 \times 10^3$  British Thermal Units (BTU). One gallon (gal)  $\approx 3.79$  liters.
2. We avoid using LCI as the abbreviation because LCI is widely used to refer to “life cycle inventory” in the life cycle assessment literature. We also avoid using “LCIA,” which stands for life cycle impact assessment, because that term refers to a type of method, rather than an outcome. “Impact” is frequently used in LCA and other environmental analysis domains to indicate quantifiable effect/damage that is associated with an emission. We use it here in order to have a term that can be applied to both environmental and economic outcomes.
3. One kilogram (kg, SI)  $\approx 2.204$  pounds (lb).
4. One liter (L) = 0.001 cubic meters (m<sup>3</sup>, SI)  $\approx 0.264$  gallons (gal).
5. Note that other greenhouse gases (GHGs) were not included in this analysis. The model is capable of incorporating a broader range of GHGs, but only CO<sub>2</sub> was addressed in this study.

## REFERENCES

- Allenby, B. 1991. Design for environment: A tool whose time has come. *Semiconductor Safety Association Journal* September: 5–9.
- Allenby, B. 2000. Implementing industrial ecology: The AT&T matrix system. *Interfaces* 30(3): 42– 54.
- Allenby, B. and J. Fink. 2005. Toward inherently secure and resilient societies. *Science* 309: 1034-1036.
- Alliance for Water Efficiency. n.d.(a). Household leak detection and mitigation introduction. [www.allianceforwaterefficiency.org/Household\\_Leaks.aspx](http://www.allianceforwaterefficiency.org/Household_Leaks.aspx). Accessed 2 August 2010.
- Alliance for Water Efficiency. n.d.(b). Metering introduction. [www.allianceforwaterefficiency.org/metering.aspx](http://www.allianceforwaterefficiency.org/metering.aspx). Accessed 2 August 2010.
- American Water Works Association. 2012. Tiered water rates. <http://www.awwa.org/Resources/topicspecific.cfm?ItemNumber=3649&navItemNumber=3650>. Accessed 23 September 2012.
- Azapagic, A. and R. Clift. 1999. Life cycle assessment and multiobjective optimisation. *Journal of Cleaner Production* 7(2):135–143(9).
- Badger Meter Inc. 2010. Making fixed network AMI an integral part of your conservation plan. Presented at the *Smart Water Innovations Conference and Exposition*, 6-8 October, Las Vegas, NV. <http://www.watersmartinnovations.com/2010/PDFs/10-F-1024.pdf>. Accessed 4 July 2011.
- Barbarella. 2007. Defensible landscape. *San Diego Reader*. 8 November. [www.sandiegoreader.com/news/2007/nov/08/defensible-landscape/](http://www.sandiegoreader.com/news/2007/nov/08/defensible-landscape/). Accessed 10 April 2010.
- Barringer, F. 2011. New electricity meters stir fears. *The New York Times*. 30 January. <http://www.nytimes.com/2011/01/31/science/earth/31meters.html>. Accessed 4 July 2011.
- Barton, A.F., M.R. Wallis, J.E. Sargison, A. Buia, and G.J. Walker. 2008. Hydraulic roughness of biofouled pipes, biofilm character, and measured improvements from cleaning. *Journal of Hydraulic Engineering* 134(6): 852-857.

- Britton, T., G. Cole, R. Stewart, and D. Wiskar. 2008. Remote diagnosis of leakage in residential households. *Water*: 56-60.  
[http://www98.griffith.edu.au/dspace/bitstream/10072/22554/1/52198\\_1.pdf](http://www98.griffith.edu.au/dspace/bitstream/10072/22554/1/52198_1.pdf).  
 Accessed 4 July 2011.
- Brown, P. 2003. Turfgrass consumptive use values for the Phoenix area. *The University of Arizona Turf Irrigation Management Series 5*: 1-3.  
<http://ag.arizona.edu/pubs/water/az1314.pdf>. Accessed 12 August 2010.
- Brown, R. 2009. Energy consumption of irrigation controllers. *Lawrence Berkeley National Laboratory 1*. June.  
[http://www.energy.ca.gov/appliances/irrigation/documents/2009-06-01\\_workshop/presentations/Brown\\_Rich\\_LBNL\\_Irrigation\\_Controls.pdf](http://www.energy.ca.gov/appliances/irrigation/documents/2009-06-01_workshop/presentations/Brown_Rich_LBNL_Irrigation_Controls.pdf).  
 Accessed 12 August 2010.
- Bruneau, M., S.E. Chang, R.T. Eguchi, G.C. Lee, T.D. O'Rourke, A.M. Reinhorn, M. Masanobu Shinozuka, K. Tierney, W.A. Wallace, and D. von Winterfeldt. 2003. A Framework to Quantitatively Assess and Enhance the Seismic Resilience of Communities. *Earthquake Spectra* 19(4): 733-752.
- Brzozowski, C. 2010. Pump technology. *Water Efficiency*: 38-41.
- California Department of Water Resources. February 2010. *20x2020 water conservation plan*.  
<http://www.water.ca.gov/wateruseefficiency/sb7/docs/20x2020plan.pdf>.  
 Accessed 6 September 2012.
- Carnegie Mellon University. 2010. Economic input-output life cycle assessment. [www.eiolca.net/cgibin/dft/use.pl](http://www.eiolca.net/cgibin/dft/use.pl). Accessed 6 May 2010.
- Christopher, G., T. Cieslak, J. Pavlin, and E. Eitzen Jr. 1997. Biological warfare: A historical perspective. *JAMA* 278(5): 412-417.
- City of Phoenix. August 2009. *Phoenix single family in-home visit water conservation program: Design, implementation, evaluation and impact*. Denver: BBC Research and Consulting.  
<http://www.bbcresearch.com/reports/BBC%20AWWA%20Journal%20Article.pdf>. Accessed 4 July 2011.
- City of Phoenix Water Services Department. 2010. Water and sewer rate information.  
<http://phoenix.gov/waterservices/customerservices/payment/rates/index.html>. Accessed 7 April 2010.

- City of Riverside Public Utilities Department. 2009. Schedule WA-1 residential metered service. [www.riversideca.gov/utilities/water-rulesandrates.asp](http://www.riversideca.gov/utilities/water-rulesandrates.asp). Accessed 10 April 2010.
- City of Riverside Public Works Department. 2010. Sewer service monthly rates. [www.riversideca.gov/sewer/pdf/Sewer-Rates.pdf](http://www.riversideca.gov/sewer/pdf/Sewer-Rates.pdf). Accessed 20 April 2010.
- City of Tucson Water Department. 2005. Residential water usage comparison. [www.ci.tucson.az.us/water/usage\\_comparison.htm](http://www.ci.tucson.az.us/water/usage_comparison.htm). Accessed 7 April 2010.
- City of Tucson Water Department. 2009. Current water rate schedules. [www.ci.tucson.az.us/water/rates.htm](http://www.ci.tucson.az.us/water/rates.htm). Accessed 7 April 2010.
- Clark County Water Reclamation District. 2010. Current sewer service rates. [www.cleanwaterteam.com/pdf/facility/main/notice\\_of\\_sewer\\_service\\_rates\\_effective\\_070701\\_rev5.pdf](http://www.cleanwaterteam.com/pdf/facility/main/notice_of_sewer_service_rates_effective_070701_rev5.pdf). Accessed 20 April 2010.
- Cohen, M., G. Wolff, and B. Nelson. August 2004. *Energy down the drain: The hidden costs of California's water supply*. New York: Natural Resources Defense Council.
- Collins, K. 2010. SRP: A water/power nexus for over a hundred years – Analysis of the embedded electricity in water for a single-family home in the City of Phoenix. Presented at the *Smart Water Innovations Conference and Exposition*, 6-8 October, Las Vegas, NV. <http://www.watersmartinnovations.com/2010/PDFs/10-W-1006.pdf>. Accessed 4 July 2011.
- Conrad, S., R. LeClaire, G. O'Reilly, and H. Uzunalioglu. 2006. Critical national infrastructure reliability modeling and analysis. *Bell Labs Technical Journal* 11(3): 57–71.
- Cooley, H. and P.H. Gleick. 2009. Urban water-use efficiencies: Lessons from United States cities. In *The world's water: 2008-2009*, edited by P.H. Gleick. Washington, D.C.: Island Press.
- Day, H. and K. Conway. 2009. Rule 1: No watts no water; Rule 2: No water no watts. Paper presented at the *24th Annual WasteReuse Symposium: Where Has All the Water Gone? Water Reuse and Desalinization: Solutions for the Future*, 13–16 September, Seattle, WA.

- Devitt, D., K. Carstensen, and R. Morris. 2008. Residential water savings associated with satellite-based ET irrigation controllers. *Journal of Irrigation and Drainage Engineering* 134(1): 74–82.
- East Bay Municipal Utility District. n.d. Self-adjusting irrigation controller rebate program. <http://www.ebmud.com/for-customers/water-conservation-rebates-and-services/self-adjusting-irrigation-controller-rebate-pr>. Accessed 6 September 2012.
- Engle, D. 2010. Leak busters: Ultra-accurate new residential meters and methods can zap “ghost” water accounts. *Water Efficiency*: 22-29.
- Fiskel, J. 2003. Designing resilient, sustainable systems. *Environmental Science & Technology* 37(23): 5330-5339.
- Frisco Public Works. 2010. About smart controller technology. [www.ci.frisco.tx.us/departments/publicworks/water/smartcontroller/Pages/AboutSmartControllers.aspx](http://www.ci.frisco.tx.us/departments/publicworks/water/smartcontroller/Pages/AboutSmartControllers.aspx). Accessed 10 February 2010.
- Froehlich, J., E. Larson, T. Campbell, C. Haggerty, J. Fogarty, and S. Patel. 2009. HydroSense: Infrastructure-mediated single-point sensing of whole-home water activity. Paper presented at *UbiCom*, 30 September to 3 October, Orlando, Florida.
- Gertner, J. 2007. The future is drying up. *The New York Times*. 21 October. [www.nytimes.com/2007/10/21/magazine/21water-t.html](http://www.nytimes.com/2007/10/21/magazine/21water-t.html). Accessed 13 May 2010.
- Gleick, P., P. Loh, S. Gomez, and J. Morrison. May 1995. *California water 2020: A sustainable vision*. Oakland: Pacific Institute for Studies in Development, Environment, and Security.
- Gleick, P.H. 1998. Water in crisis: Paths to sustainable water use. *Ecological Applications* 8(3): 571-579.
- Graedel, T. and B. Allenby. 2003. *Industrial ecology*. Upper Saddle River, NJ: Prentice Hall.
- Haines, Y., N. Matalas, J. Lambert, B. Jackson, and J. Fellows. 1998. Reducing vulnerability of water supply systems to attack. *Journal of Infrastructure Systems* December issue: 164-177.
- Hall-Stoodly, L. and P. Stoodly. 2005. Biofilm formation and dispersal and the transmission of human pathogens. *TRENDS in Microbiology* 13(1): 7-10.

- Hallin, B. and D. Holton. 2008. Collaborating on water/power efficiency programs. [www.energystar.gov/ia/partners/downloads/meetings/water\\_SaltRiverProject.pdf](http://www.energystar.gov/ia/partners/downloads/meetings/water_SaltRiverProject.pdf). Accessed 22 April 2010.
- Harris, R. 2010a. WaterSmart Toolbox: Giving customers online access to real-time water consumption is the right tool for water efficiency success. Presented at the *Smart Water Innovations Conference and Exposition*, 6-8 October, Las Vegas, NV. <http://watersmartinnovations.com/2010/PDFs/10-T-1001.pdf>. Accessed 10 July 2011.
- Harris, R. 2010b. What side of the meter are you on?: Proactively looking and listening for leaks on pipes and aqueducts. Presented at the *Smart Water Innovations Conference and Exposition*, 6-8 October, Las Vegas, NV. <http://www.watersmartinnovations.com/posters-sessions/2010/PDFs/10-F-1005.pdf>. Accessed 6 September 2012.
- Hauber-Davidson, G. and E. Idris. 2006. Smart water metering. *Water* 33(3): 38–41.
- Hausman, J. 1979. Individual discount rates and the purchase and utilization of energy-using durables. *The Bell Journal of Economics* 10(1): 33-54.
- Holling, C.S. 2001. Understanding the complexity of economic, ecological, and social systems. *Ecosystems* 4: 390-405.
- House, L. and J. House. 2012. Shifting the time of customer water consumption. *Journal – American Water Works Association* 104(2): 43-44.
- Howarth, R. and A. Sanstad. 1995. Discount rates and energy efficiency. *Contemporary Economic Policy* 13(3): 101-109.
- Hunaidi, O., A. Wang, M. Bracken, T. Gambino, and C. Fricke. 2005. Detecting leaks in water distribution pipes. *Arab Water World* 29(4): 52-55.
- Igo, M. 2010. Creating a sustainability index through irrigation alternative analysis. Presented at the *Smart Water Innovations Conference and Exposition*, 6-8 October, Las Vegas, NV. <http://watersmartinnovations.com/2010/PDFs/10-W-1027.pdf>. Accessed 10 July 2011.
- Ishii, K., C. Eubanks, and P. Di Marco. 1994. Design for product retirement and material life cycle. *Materials and Design* 15(4): 225–233.

- Karim, M., M. Abbaszadegan, and M. LeChevallier. 2003. Potential for pathogen intrusion during pressure transients. *Journal – American Water Works Association* 95(5): 134-146.
- Karl, T.R., G.A. Meehl, C.D. Miller, S.J. Hassol, A.M. Waple, and W.L. Murray. 2008. *Weather and climate extremes in a changing climate; Regions of focus: North America, Hawaii, Caribbean, and U.S. Pacific Islands*. Washington, D.C.: U.S. Climate Change Science Program and the Subcommittee on Global Change Research, Department of Commerce, NOAA's National Climatic Data Center.
- Kenna, B. October 2008. *Water metering and revenue protection*. Queensland, Australia: University of Southern Queensland.  
[http://eprints.usq.edu.au/6114/1/Kenna\\_2008.pdf](http://eprints.usq.edu.au/6114/1/Kenna_2008.pdf). Accessed 10 July 2011.
- Kenny, J., N. Barber, S. Huston, K. Linsey, J. Lovelace, and M. Maupin. 2009. Estimated use of water in the United States in 2005. In *U.S. Geological Survey Circular* 1344. Reston, VA: U.S. Geological Survey.
- Keoleian, G. 1993. The application of life cycle assessment to design. *Journal of Cleaner Production* 1(3–4): 143–149.
- Khalifa, T., K. Naik, and A. Nayak. 2011. A survey of communication protocols for automatic meter reading applications. *IEEE Communication Surveys & Tutorials* 13(2): 168-182.
- Kieffer, J. and A. Miller. 2010. Implications of systematic integration of water efficient technology. Presented at the *Smart Water Innovations Conference and Exposition*, 6-8 October, Las Vegas, NV.  
<http://www.watersmartinnovations.com/2010/PDFs/10-T-1009.pdf>.  
 Accessed 10 July 2011.
- Las Vegas Sun. 2010. Using water, using power. *Las Vegas Sun*. 19 March.
- Las Vegas Valley Water District. 2010. Rates and usage thresholds.  
[www.lvwwd.com/custserv/billing\\_rates\\_thresholds.html](http://www.lvwwd.com/custserv/billing_rates_thresholds.html). Accessed 4 April 2010.
- Lin, M., Y. Wu, and I. Wassell. 2008. Wireless SensorNetwork: Water distribution monitoring system. Presented at the *2008 IEEE Radio and Wireless Symposium*, 22-24 January, Orlando, FL.  
[http://www.cl.cam.ac.uk/research/dtg/www/files/publications/public/ml406/Wireless%20Sensor%20Network\\_Water%20Distribution%20Monitoring%20System.pdf](http://www.cl.cam.ac.uk/research/dtg/www/files/publications/public/ml406/Wireless%20Sensor%20Network_Water%20Distribution%20Monitoring%20System.pdf). Accessed 10 July 2011.

- Los Angeles County of Public Works. 2010. Water conservation.  
<http://dpw.lacounty.gov/WWD/web/conserves.cfm>. Accessed 15 April 2010.
- Los Angeles Department of Water and Power. 2010. Water rates.  
[www.ladwp.com/ladwp/cms/ladwp001068.jsp](http://www.ladwp.com/ladwp/cms/ladwp001068.jsp). Accessed 10 April 2010.
- Maier, R.M., I.L. Pepper, and C.P. Gerba C.P. 2009. *Environmental Microbiology, 2nd, ed.* Burlington, MA: Elsevier, Inc.
- Mansur, E.T. and S.M. Olmstead. n.d. The value of scarce water: Measuring the inefficiency of municipal regulations.  
[http://www.frbatlanta.org/podcasts/061709drought\\_pricing\\_revised.pdf](http://www.frbatlanta.org/podcasts/061709drought_pricing_revised.pdf).  
 Accessed 10 July 2011.
- Martin, C. 2001. Landscape water use in Phoenix, Arizona. *Desert Plants* 17: 26–31.
- Martin, C. 2008. Landscape sustainability in a Sonoran Desert City. *Cities and the Environment* 1(2), 1-16.
- Martin, C., K. Peterson, and L. Stabler. 2003. Residential landscaping in Phoenix, Arizona, U.S.: Practices and Preferences Relative to Covenants, Codes, and Restrictions. *Journal of Arboriculture* 29(1): 9-17.
- Mayer, P.W. and W.B. DeOreo. 1999. *Residential End Uses of Water*. American Water Works Association.
- Mayer, P., W. DeOreo, M. Hayden, and R. Davis. 2009. *Evaluation of California weather-based “smart” irrigation controller programs*. Boulder, CO: Aquacraft, Inc.
- McKinnon, S. 2007. Cities’ conservation goal: Patch own water leaks. *AZCentral*. 21 May. <http://www.azcentral.com/specials/special26/articles/0521leaks-cities0522.html>. Accessed 2 October 2010.
- Meinhardt, P. 2005. Water and Bioterrorism: Preparing for the potential threat to U.S. water supplies and public health. *Annu Rev Public Health* 26: 213–37.
- Metropolitan Water District of Southern California. July 2009. *Evaluation of California weather-based “smart” irrigation controller programs*. Denver.



- Michalek, J., P. Papalambros, and S. Skerlos. 2004. A study of fuel efficiency and emission policy impacts on optimal vehicle design decisions. *Transactions of the ASME* 126: 1062–1070.
- Milman, A, and A. Short. 2008. Incorporating resilience into sustainability indicators: An example for the urban water sector. *Global Environmental Change* 18: 758-767.
- Mistry, P. n.d. Pressure management to reduce water demand & leakage. <http://findmoreleaks.com/downloads/Pressure%20Management%20to%20Reduce%20Water%20Demand.pdf>. Accessed 10 July 2011.
- Modeer, D. 2006. On the water front. *Your Water Connection: News & Tips for Tucson Water Customers* May. [www.tucsonaz.gov/water/docs/wc200605.pdf](http://www.tucsonaz.gov/water/docs/wc200605.pdf). Accessed 12 August 2010.
- Mutchek M.A. and E.D. Williams. 2010 Design space characterization for meeting cost and carbon reduction goals. *Journal of Industrial Ecology* 14(5): 727-739.
- National Drinking Water Clearinghouse. May 2001. *Leak detection and water loss control*. Morgantown, WV. [http://www.nodp.wvu.edu/pdf/dw/publications/ontap/2009\\_tb/leak\\_detection\\_DWFSOM38.pdf](http://www.nodp.wvu.edu/pdf/dw/publications/ontap/2009_tb/leak_detection_DWFSOM38.pdf). Accessed 10 July 2011.
- O'Rourke, T.D. 2007. Critical infrastructure, interdependencies, resilience. *The Bridge Spring* issue: 22-29.
- Pima County. 2010. Pima County, Arizona, Code of Ordinances, Title 13 – Public Services, Division II. – Sewers, Chapter 13.24 – Sanitary Sewers, Section 180 – Volume rate and service fee schedules.
- PUB. June 2011a. *Innovation in water Singapore, Volume 1*. [http://www.pub.gov.sg/mpublications/Lists/WaterInnovationPublication/Attachments/7/InnovationWater\\_vol1.pdf](http://www.pub.gov.sg/mpublications/Lists/WaterInnovationPublication/Attachments/7/InnovationWater_vol1.pdf). Accessed 6 September 2012.
- PUB. March 2012b. *Innovation in water Singapore, Volume 2*. [http://www.pub.gov.sg/mpublications/Lists/WaterInnovationPublication/Attachments/8/InnovationWater\\_vol2.pdf](http://www.pub.gov.sg/mpublications/Lists/WaterInnovationPublication/Attachments/8/InnovationWater_vol2.pdf). Accessed 6 September 2012.
- PUB. July 2012c. *Innovation in water Singapore, Volume 3*. [http://www.pub.gov.sg/mpublications/Lists/WaterInnovationPublication/Attachments/9/InnovationWater\\_vol3.pdf](http://www.pub.gov.sg/mpublications/Lists/WaterInnovationPublication/Attachments/9/InnovationWater_vol3.pdf). Accessed 6 September 2012.

- Riverside County Task Force. 2008. 2008 summer/fall factoids.  
[www.h2oriversidecounty.org/LinkClick.aspx?fileticket=pZ2Hb2oJz8M%3D&tabid=62](http://www.h2oriversidecounty.org/LinkClick.aspx?fileticket=pZ2Hb2oJz8M%3D&tabid=62). Accessed 10 April 2010.
- Reisner, M. 1986. *Cadillac desert: The American West and its disappearing water*. New York: Viking.
- Rothstein, E. and D. Galardi. 2012. Financing water utilities' sustainability initiatives: Challenging institutionalized governance and market failures. Presented at the *American Water Works Association Sustainable Water Management Conference*, 18-21 March, Portland, OR.
- Ruggaber, T., J. Talley, and L. Montestruqu. 2007. Using embedded sensor networks to monitor, control, and reduce CSO events: A pilot study. *Environmental Engineering Science* 24(2): 172-182.
- Sadiq, R., K. Yehuda, and B. Rajani. 2006. Estimating risk of contaminant intrusion in water distribution networks using Dempster-Shafer theory of evidence. *Civil Engineering and Environmental Systems* 23(3): 129-141.
- Simonite, T. 2011. This 45-Mile 'Wi-Fi' could connect a smarter power grid. *Technology Review*. 28 June.  
<http://www.technologyreview.com/computing/37881/page1/>. Accessed 10 July 2011.
- State of Arizona. October 2004. *Arizona drought preparedness plan: Background & impact assessment section*.
- Stoianov, I., L. Nachman, and S. Madden. 2007. Pipenet: A wireless sensor network for pipeline monitoring. Presented at *IPSN'07*, 25-27 April, Cambridge. <http://db.csail.mit.edu/pubs/ipsn278-nachman.pdf>. Accessed 10 July 2011.
- Sweet, P. 2008. Water: The more you use, the more you'll have to pay. *The Las Vegas Sun*. [www.lasvegassun.com/news/2008/apr/08/water-more-you-use-more-youll-have-pay/](http://www.lasvegassun.com/news/2008/apr/08/water-more-you-use-more-youll-have-pay/). Accessed 8 April 2010.
- The City of San Diego Public Utilities: Water. 2010a. Water & sewer bill/rates. [www.sandiego.gov/water/rates/rates.shtml](http://www.sandiego.gov/water/rates/rates.shtml). Accessed 10 April 2010.
- The City of San Diego Public Utilities: Water. 2010b. Water conservation tips. [www.sandiego.gov/water/conservation/tips.shtml](http://www.sandiego.gov/water/conservation/tips.shtml). Accessed 10 April 2010.

- The Environmental Advisory Council to the Swedish Government. April 2002. *Resilience and sustainable development: Building adaptive capacity in a world of transformations*. Stockholm: EDITA NORSTEDTS TYCKERI AB.
- The Utility Connection. n.d. <http://www.utilityconnection.com/>. Accessed 10 July 2011.
- Toto. n.d. Self-sustaining faucets. <http://www.totousa.com/Green/Products/EcoPowerFaucets.aspx>. Accessed 17 July 2011.
- UrbanFlood. n.d. Introduction to UrbanFlood. <http://www.urbanflood.eu/Pages/default.aspx>. Accessed 8 June 2012.
- U.S. Bureau of Economic Analysis. 2010. Industry economic accounts: Interactive access to input-output accounts data. <http://bea.gov/industry/iotables>. Accessed 29 April 2010.
- U.S. Bureau of Labor Statistics. 2010. Producer price indexes. [www.bls.gov/ppi/](http://www.bls.gov/ppi/). Accessed 8 May 2010.
- U.S. Bureau of Reclamation. 2004. Weather based technologies for residential irrigation scheduling. *Reclamation: Managing Water in the West* May. [www.usbr.gov/waterconservation/docs/ET%20controller%20report.pdf](http://www.usbr.gov/waterconservation/docs/ET%20controller%20report.pdf). Accessed 12 August 2010.
- U.S. Bureau of Reclamation (USBR). 2007. Weather and soil moisture based landscape irrigation scheduling devices. *Reclamation: Managing Water in the West* August. [www.usbr.gov/waterconservation/docs/SmartController.pdf](http://www.usbr.gov/waterconservation/docs/SmartController.pdf). Accessed 12 August 2010.
- U.S. Bureau of Reclamation. 2008. Summary of smart controller water savings studies. *Reclamation: Managing Water in the West* April. Final technical memorandum No. 86-68210-SCAO-01. [www.usbr.gov/waterconservation/docs/WaterSavingsRpt.pdf](http://www.usbr.gov/waterconservation/docs/WaterSavingsRpt.pdf). Accessed 12 August 2010.
- U.S. Department of Energy. 2002. Updated state-level greenhouse gas emission coefficients for electricity generation 1998-2000. Washington, DC: Energy Information Administration.
- U.S. Department of Energy. 2007. Federal energy management program. [www1.eere.energy.gov/industry/technologies](http://www1.eere.energy.gov/industry/technologies). Accessed 7 July 2010.

- U.S. Department of Energy. November 2009. *Preliminary technical support document: Energy efficiency program for consumer products: Refrigerators, refrigerator-freezers, and freezers*. Office of Energy Efficiency and Renewable Energy.
- U.S. Department of Energy. n.d. The smart grid: An introduction. [http://www.oe.energy.gov/DocumentsandMedia/DOE\\_SG\\_Book\\_Single\\_Pages%281%29.pdf](http://www.oe.energy.gov/DocumentsandMedia/DOE_SG_Book_Single_Pages%281%29.pdf). Accessed 8 May 2011.
- U.S. Energy Information Administration. 2010. Electric power annual 2008 – state data tables. [www.eia.doe.gov/cneaf/electricity/epa/epa\\_sprdshts.html](http://www.eia.doe.gov/cneaf/electricity/epa/epa_sprdshts.html). Accessed 6 February 2010.
- U.S. Environmental Protection Agency. August 2002. *Effects of water age on distribution system water quality*. Washington, D.C. [http://www.epa.gov/ogwdw/disinfection/tcr/pdfs/whitepaper\\_tcr\\_waterdistribution.pdf](http://www.epa.gov/ogwdw/disinfection/tcr/pdfs/whitepaper_tcr_waterdistribution.pdf). Accessed 25 September 2012.
- U.S. Environmental Protection Agency. 2004. How we use water in these United States. [www.epa.gov/watrhome/you/chap1.html](http://www.epa.gov/watrhome/you/chap1.html). Accessed 1 January 2004.
- U.S. Environmental Protection Agency. 2009. *Distribution system water quality monitoring: Sensor technology evaluation methodology and results*. Cincinnati.
- U.S. Environmental Protection Agency. 2010. Methodology and assumptions for estimating WaterSense annual accomplishments. [www.epa.gov/watersense/docs/methodology\\_and\\_assumptions\\_formatted\\_508.pdf](http://www.epa.gov/watersense/docs/methodology_and_assumptions_formatted_508.pdf). Accessed 15 July 2010.
- Vaseashta, A. 2011. Technological advances water safety, security, and sustainability. Presented at the *Second International Congress on Sustainability Science and Engineering*, 9-12 January, Tucson, AZ.
- Weng, K.T. and A. Lim. 2012. Pursuit of a smart water grid in Singapore's water supply network. Presented at the *American Water Works Association Sustainable Water Management Conference*, 18-21 March, Portland, OR.
- Wentz, E. and P. Gober. 2007. Determinants of small-area water consumption for the city of Phoenix, Arizona. *Water Resource Management* 21(11): 1849-1863.

Williams, E. 2011. Environmental effects of information and communication technologies. *Nature* 479: 354-358.

APPENDIX

PERMISSION FOR CO-AUTHORED WORKS

The content of Chapter 3 of this thesis comes from the published paper “Design Space Characterization for Meeting Cost and Carbon Reduction Goals: Smart Irrigation Controllers in the Southwest U.S.” in the *Journal of Industrial Ecology*, Volume 14, Issue 5, October 2010 by Michele Mutchek and Eric Williams. Eric Williams gives his permission to use this published paper in this thesis.