

A Practical and Theoretical Approach to Understanding the Selective  
Mechanisms Behind Genetic Caste Determination in *Pogonomyrmex rugosus*

and *Pogonomyrmex barbatus*

by

Neal Jacobson

A Thesis Presented in Partial Fulfillment  
of the Requirements for the Degree  
Master of Science

Approved April 2012 by the  
Graduate Supervisory Committee:

Chair: Juergen Gadau  
Member: Stephen Pratt  
Member: Manfred Laubichler

ARIZONA STATE UNIVERSITY

May 2012

## ABSTRACT

Gene-centric theories of evolution by natural selection have been popularized and remain generally accepted in both scientific and public paradigms. While gene-centrism is certainly parsimonious, its explanations fall short of describing two patterns of evolutionary and social phenomena: the evolution of sex and the evolution of social altruism. I review and analyze current theories on the evolution of sex. I then introduce the conflict presented to gene-centric evolution by social phenomena such as altruism and caste sterility in eusocial insects. I review gene-centric models of inclusive fitness and kin selection proposed by Hamilton and Maynard Smith. Based their assumptions, that relatedness should be equal between sterile workers and reproductives, I present several empirical examples that conflict with their models. Following that, I introduce a unique system of genetic caste determination (GCD) observed in hybrid populations of two sister-species of seed harvester ants, *Pogonomyrmex rugosus* and *Pogonomyrmex barbatus*. I review the evidence for GCD in those species, followed by a critique of the current gene-centric models used to explain it. In chapter two I present my own theoretical model that is both simple and extricable in nature to explain the origin, evolution, and maintenance of GCD in *Pogonomyrmex*. Furthermore, I use that model to fill in the gaps left behind by the contributing authors of the other GCD models. As both populations in my study system formed from inter-specific hybridization, I review modern discussions of heterosis (also called hybrid vigor) and use those to help explain the ecological competitiveness of GCD. I empirically address the inbreeding depression the

lineages of GCD must overcome in order to remain ecologically stable, demonstrating that as a result of their unique system of caste determination, GCD lineages have elevated recombination frequencies. I summarize and conclude with an argument for why GCD evolved under selective mechanisms which cannot be considered gene-centric, providing evidence that natural selection can effectively operate on non-heritable genotypes appearing in groups and other social contexts.

## DEDICATION

I would like to dedicate this thesis to my father, as his encouragement and enthusiasm were both inspiring and motivational.

## ACKNOWLEDGMENTS

I would like to thank my committee for their continual patience and enduring faith, as my ideas were somewhat radical at times. I would also like to thank members of Jürgen Gadau's lab, as they listened and critiqued the radical ideas I was afraid of sharing with my committee. I would also like to recognize my significant other, Corinne DeRuiter, as a crucial element of my success. Without her support I would have dropped out of school long ago and pursued other less tangible dreams.

# TABLE OF CONTENTS

	Page
LIST OF TABLES.....	vi
LIST OF FIGURES.....	vii
PREFACE.....	viii
CHAPTER	
1 COMPONENTS OF NATURAL SELECTION: GENE CENTRIC VIEWS ON EVOLUTION AND THE CAVEATS TO ITS EXPLANATORY MONOPOLY .....	1
General Components of Selection.....	1
The Cost of Meiosis and Sexual Reproduction .....	9
Social Altruism, Inclusive Fitness, and Kin Selection .....	22
The <i>Pogonomyrmex</i> Dependent Lineage System.....	34
2 A THEORETICAL AND PRACTICAL APPROACH TO UNDERSTANDING THE EVOLUTION OF GENETIC CASTE DETERMINATION .....	49
Genetic Caste Determination.....	50
A GRN Model for the Evolution of the DLs in <i>Pogonomyrmex</i> ....	56
The Establishment of the H-Lineages .....	61
Sympatric Isolation of Hybrid Lineages .....	65
Overcoming the Inbreeding Depression of Intra-Lineage Mating..	74
Conclusion of Thesis .....	88
REFERENCES .....	94

## LIST OF TABLES

Table		Page
1.	Hypothetical Caste Determination in Mellipona.....	30
2.	Recombination Frequency in Scaffold 1 .....	83
3.	Recombination Frequency in Scaffold 3 .....	83

## LIST OF FIGURES

Figure		Page
1.	Lineage Divergence from Parental Species.....	39
2.	GCD Phylogeny of <i>Pogonomyrmex</i> .....	52
3.	The GRN for ECD in both Species .....	57
4.	The F <sub>1</sub> Hybrid Genotype and Phenotype .....	58
5.	Crossing Over in the F <sub>1</sub> Genotypes .....	58
6.	Establishment of both J-Lineages .....	59
7.	The Worker Genotype.....	60
8.	Establishment of both H-Lineages .....	64
9.	Recombination Frequency in Scaffold 1 .....	83
10.	Recombination Frequency in Scaffold 3 .....	83
11.	Recombination Comparison between Shared Markers on Scaffold 1	84
12.	Recombination Comparison between Shared Markers on Scaffold 3	84



## PREFACE

The process of evolution by natural selection proceeds by non-random patterns of change; thus, from it we are able to construct models that describe and predict changes in trait-form frequency based on the perceived relationship between a particular trait-form and its relative adaptive value. Therefore, evolution by means of natural selection is the single most, unifying theory of biological science. It is built on several principles; those of innate variation, heritability, and gradual adaptation by differential reproduction and survival.

Natural selection provides an explanatory mechanism by which all biological life, past and present, has continued to evolve and diversify on a landscape of uncertainty. Because of that, we as scientists are continually challenged to define the borders and rules by which it operates. Often we find ourselves forced to abandon the eloquent theories of our upbringing and embrace the confusion of exception. As scientists we take pride in our ability to restrain bias from our principles, yet we cling to outdated paradigms because we fear the unexplainable. Let us take off that blindfold and stare uncertainty in the eye, because we are not afraid to say, "I simply don't know."

## Chapter 1

### COMPONENTS OF NATURAL SELECTION: GENE CENTRIC VIEWS ON EVOLUTION AND THE CAVEATS TO ITS EXPLANATORY MONOPOLY

#### **General Components of Selection**

With the advance of biological inquiry, numerous components have been identified that comprise the machine of natural selection. Those components directly influence various levels of biological organization, from how ecosystems and populations are constructed all the way down to the developmental processes that integrate to form an embryo. Most of the components of natural selection test how well an organism “fits” with its immediate environment.

We know intuitively that polar bears will not do especially well in a rainforest; and likewise, koala bears would not be comfortable in the artic. Both scenarios would likely result in no reproductive output for those individuals in those environments. Thus, *fit*-ness is typically measured in terms of potential reproductive success resulting from the continual interaction between an individual and their immediate environment. Fitness is essentially a synonymous expression or measure of adaptive value. Because most organisms are a collection of different trait-forms, fitness can be used in terms of the adaptive value of a specific collection of traits—or the overall adaptive value of an individual.

We have long recognized that certain traits or characteristics will aid organisms in their survival, depending on the demands of their environment. Some traits are incredibly invariable, such as the white colored fur of polar bears. Some are incredibly variable, such as height and weight in humans. Therefore, it

becomes necessary to delineate which traits are actually effectible by natural selection and which are not.

Traits that are effectible by natural selection must vary within a population. That is to say, more than one trait-*form* must be present in order for natural selection to affect that trait. Trait-forms, as they appear in different individuals, are subjected to a common selective environment where one trait-form may increase or decrease the overall fitness of the individual who carries it; and thus, the relative frequency of that trait-form in the population will increase or decrease. Given a common selective environment, we are at liberty to say that one trait-form has a higher adaptive value than another trait-form if and only if a correlation exists between it and the fitness of the individual who carries it. We can then call any trait with a higher adaptive value an *advantageous* trait, respective to one with a lower adaptive value, provided they both share a common selective environment.

In order for natural selection to favor one trait-form over another, the trait-forms themselves must be heritable from one generation to the next and differ in one or more characteristics. Imagine a population of humans living in the Savannah of Africa. Now imagine that *running speed* is a trait that is heritable and varies in its character within that population (some people are faster, some are slower). Now consider that people who are *faster than average* have a better chance at survival; possibly to outrun a hungry lion, or perhaps just to outrun a slower person who is also being chased by that same lion. In order for that trait to be effectible by natural selection, people who are faster than average must have

faster than average children. Also, that trait must vary within the population. If every person running from a hungry lion were equally fast, then it would be impossible for selection to favor the trait-form *quickness*. In other words, that trait-form could not be considered *advantageous*. The term *advantageous* infers a relationship between two objects—in this case two different forms of a trait, and their relative adaptive values.

Lastly, selection can only work if there is differential reproduction and survival between individuals that carry different trait-forms. That is essentially synonymous of potential reproductive success but given in terms of absolute value (net yield of surviving and reproducing offspring). Imagine that faster than average people produce only two children over the course of their life; possibly because they are too busy running. Now let's say slower than average people produce twenty children. If both trait-forms start at equal frequency and lions only eat one slow person a year, then *slower than average* people would actually have more fitness relative to *faster than average* people over generational time (i.e. they would leave behind more children). Therefore, in order for one trait-form to be advantageous or selected over another, individuals carrying that trait-form must produce more offspring *who also survive and reproduce* than other individuals absent of that trait-form. Or, to use the language of population genetics, the frequency of that trait-form must increase in the population over generational time.

We have now arrived at three necessary conditions or axioms that must be met in order for evolution to occur by natural selection. The first is variation, a

trait must be variable in order for selection to differentiate between forms of that trait; the second is heritability, a trait-form must be heritable from parent to offspring; and third, individuals with one trait-form must have higher or lower levels of fitness than individuals with different forms of that trait, respectively.

### **Historical Perspective on Traits**

At the time of Darwin, trait-forms were considered to be one and the same as the individual. During sexual reproduction, different trait-forms were thought to blend together to construct the trait-form of the next generation. The process of blending inheritance could be considered analogous to blending two steel products together, each of which varies in strength, to make a steel product with strength somewhere in between. The major difference is that Darwin did not recognize iron and carbon to be elements of steel. He was concerned about variation in the strength of steel and how those variations were heritable. Proponents of blending inheritance, such as Darwin and Lamarck, believed that changes in trait-form (or strength of steel when using this analogy) would accrue during an organism's life cycle and then be heritably passed on during replication. In contrast to this idea, Gregor Mendel, through experimentation on trait-form inheritance in pea plants, determined that some trait-forms do not blend together and appear independent of one another in subsequent generations. Mendel's observations would be analogous to mixing two steel products together and as a result getting separate iron and carbon offspring.

Although both perspectives seemed incongruent at the time, Sir Ronald Fisher made a synthesis of the two in 1918 when he published his seminal work

on the probability of Mendelian inheritance of variation (Fisher, 1918). He demonstrated that more than two factors for a trait-form could be present in a breeding population. To use an analogy similar to the one above, Fisher recognized that an entire periodic table of elements, genetically speaking, could be present in a population; combinations of which affect the observed variation of one trait from generation to generation. Elements contributed from each parent would determine the strength of each alloy present in the next generation. Knowing the constituent elements within each parent would allow testable predictions to be made for the expected variation of offspring trait-forms. Continual mixing of multiple factors through sexual reproduction, Fisher argued, adequately explains the distribution of variation (in trait-forms) observed for a particular trait. But even more importantly than that, Fisher provided a model of inheritance that synthesized two radically different points of view.

### **Current Perspective on Traits**

We now know that most trait-forms are causally linked to the expression of specific regions or sequences of DNA. We generally refer to those trait-related sequences as “genes”. Genes are essentially cryptic, biochemical recipes, hidden between and among other virtually indistinguishable sequences of DNA. Specific components of cellular machinery work like tiny chefs, reading the code, pulling ingredients out of the cytoplasm, and assembling together chains of amino acids. Those chains carefully fold together to form various proteins or enzymes, the byproducts of which are traits. It follows that differences in coding sequence

between two copies of the same gene would result in a relative structural difference in their protein products; and hence, the trait-form they create.

We can now define those copies of genes that differ in DNA sequence as *alleles*, and call their physiological expression a trait-form. The definition of allele can then be *different forms of a particular trait* or *different sequences of a particular gene*. Likewise, a trait-form can be a protein, enzyme, or the physiological consequence that results from their interaction.

The most common distinction between genes and the pattern of traits they create is given by the phenotype/genotype distinction. An inherited collection of alleles defines the genotype of an individual. The physiological expression of the genotype, or the collective body of expressed trait-forms, defines the phenotype. That distinction, however, does not work *vice versa*. Any observed phenotype can be one of many possible expressions of *one* genotype. Genes can be expressed, dormant, or repressed, depending on the temporal and spatial environment in which they reside. When more than one phenotype is expressed temporally by one genotype, we call that change *phenotypic plasticity*; a subject I will cover more rigorously at the end of this chapter.

### **The History behind Gene-Centric Evolution**

When first discovered, genes were perhaps over-generalized to be independent operators, each coding for an independent trait or enzyme. This generalization was originally called the *one-gene, one-enzyme hypothesis* (Beadle & Tatum, 1941). But for continuity of language, I will clarify it as the *one-gene, one-trait hypothesis*. From the one-gene, one-trait hypothesis, it was believed (and

still is in many medical fields) that a genotypic analysis of an individual will provide an accurate measure of their fitness. However, because selection operates at the level of the phenotype (trait-form interaction with environment), the presence of phenotypic plasticity presents a paradox for that hypothesis. Gene products must interact in some way that phenotypic expression is different. Therefore, not all genes operate independent of one another. Gene expression depends on genetic environment. Enzymes produced from one gene can bind to the DNA of another gene and repress that gene's expression, and visa versa, changing the overall phenotype of an individual.

Therefore, one particular phenotype cannot be the focus of selection, rather, selection operates on every *possible* phenotype that one genotype can produce. A phenotype is no longer a discrete or relevant descriptive unit: are we talking about one specific phenotype of an individual or all of them? It is more succinct to discuss selection as it pertains to the genotype. Implicit in that assumption is every possible phenotype that one genotype can create. Therefore, selection acting on an individual is synonymous with selection acting on a genotype. More importantly, phenotypes are not heritable units per se; essentially, they are *vehicles* or *interactors* whose primary function is to survive and replicate the genotype (Dawkins, 1978; Hull, 1980). Therefore, transmission of genotype is the keystone for gene-centric views on evolution.

### **Gene-centric Evolution**

When considering the best way to describe natural selection, a gene-centric view of evolution is considerably parsimonious. The gene-centric view



reduces system and organism complexity. Whether we speak of single-celled organisms or multi-cellular organisms is no longer important, they all have genes. Evolutionary logic follows: genes that are around today have been the best at replication, interaction, and adaptation. Processes such as those listed are reinforced continually at the level of the genotype. Genotypes that replicate better leave behind more of themselves and their constituent alleles. Because selection acts on the product of gene interactions (expressed phenotype) at the level of a genotype, to some degree the quality of that interaction will denote that genotype's collective chance at survival and replication. Adaptation happens when a particular combination of genes creates the best vehicle for both survival and replication in a given environment.

If genes are central to the process of natural selection, then alleles that code for better *vehicles* (adapted to their environment) should associate heavily with alleles that are better *replicators* (reproduce more effectively). From the example above, a person with the good fortune of having both an allele for quickness (to escape those hungry lions) and an allele for attracting mates (high reproductive output) will leave more of those alleles behind. Teams of alleles that are good at surviving but not replicating will eventually lose out to teams that are good at both. We have now arrived at the gene-centric view of evolution: genes within a vehicle interact in such a way that replication is differential; and likewise, alleles that code for better vehicles, respectively, will survive and reproduce more effectively—leaving more of themselves behind.

From the preceding section, it would seem that a gene-centric view of evolution would explain most evolutionary novelties; however, there are two particular caveats of gene-centric evolution that deserve special attention: sexual reproduction and social altruism.

In asexual reproduction, e.g. fission, budding, spore formation, parthenogenesis, etc., the gene-centric view of evolution remains satisfactory. Genes that co-adapt together stay together following replication. As offspring are essentially clones of their parents (outside of any mutation), teams of genes with higher relative fitness are kept around. When considering sexually reproducing organisms, however, or any organism that undergoes meiosis, i.e. crossing over, independent assortment, and reduction in ploidy, followed by sexual reproduction and fertilization, genes have an entirely different problem: they are consistently broken up. This paradox is traditionally called the *Cost of Meiosis*.

### **The Cost of Meiosis and Sexual Reproduction**

Here I will use a diploid narrative to describe the *Cost of Meiosis* and its relationship with sexual reproduction. Diploidy is two sets of homologous chromosomes in one individual. For instance, humans have twenty three sets (or pairs) of homologous chromosomes; therefore, each person has forty-six potentially unique chromosomal sequences, as one homologous chromosome may contain a different allele of the same gene than another (this would be called heterozygosity).

Sexual reproduction generally results in offspring that are less related to their parents than those produced from asexual reproduction. This occurs from the

following meiotic processes: duplication of genetic material (each chromosome clones itself), an exchange of genetic material between homologous chromosomes (four homologous chromosomes differentially swap DNA sequences), independent assortment of homologous chromosomes into two diploid daughter cells, a ploidy reduction (dividing genetic material again into four haploid daughter cells, or gametes), and then fertilization between two independently created gametes (one from each parent—usually sperm and egg) to create a diploid zygote (fertilized egg). Two important steps of gametogenesis are responsible for the addition of genetic variance to the gamete. The first is the exchange of genetic material between homologous chromosomes during prophase I of meiosis, also called *crossing over*. The second is the independent assortment of chromosomes on the metaphase plate during metaphase I of meiosis (Lewin 2000).

The exchange of genetic material by crossing over eventually leads to the creation of four unique haploid gametes. In order for crossing over to occur between homologous chromosomes, DNA sequence homology is required; however, that prerequisite appears to be very general. For example, Watt et al. clarified the requirement for sequence homology in *E. coli*, showing that a linear relationship exists between sequence homology and recombination; the more homology, the higher the recombination frequency (Watt, Ingels, Urdea, & Rutter, 1985). Thus, the requirement of homologous sequence pairing is enforced on a spectrum of sequence similarity. The parameters of that spectrum are likely determined both by the evolutionary history of an organism and its current

selective environment. In other words, the threshold of homology for recombination is likely variable across taxa.

In addition to varying levels of homology, crossing over has also been shown to occur non-randomly with respect to spatial location on the chromosome. There is a general increase in recombination frequency away from the centromere (tightly bound center of the chromosome) and recombination usually does not occur within gene coding sequences (Lewin, 2000). These observations, especially the latter, imply that recombination or crossing over of genetic material is not completely random and should be considered as an important part of natural selection.

In addition to crossing over, the process of independent assortment introduces genetic variability to the gamete by orders of magnitude, depending on the total number of chromosomes present. By definition, the more homologous pairs of chromosomes that are present, the more possible combinations each daughter cell can receive following meiosis I. For humans, who have twenty three chromosomes, the probability of an individual creating the same exact set of twenty-three chromosomes in two gametes will happen one time out of  $23^2$  (1/529). The probability of creating the same haploid set of twenty-three chromosomes between each parent independently is  $(1/529)^2$ , or 1 in 279,841. By factoring in the exchange of genetic material from crossing over, that probability is decreased by another order of magnitude. Four distinct haploid chromosomes are created after duplication, crossing over, independent assortment, and ploidy reduction; therefore, even without considering the differential exchange of genetic

material between gametes during crossing over, the probability of creating the same set of chromosomes in one fertilized egg between two humans is on the order of  $(1/92^2)^2$  or  $1.4 \times 10^{-8}$ . Therefore, it is sufficient to say that sexual reproduction is not in the business of creating exact genetic replicates of the parents in each generation. Because of that, sexual reproduction brings the gene-centric view of evolution into question. If parents are only half-related to their offspring, then sexual reproduction eliminates up to half of the parent's genes per offspring produced. Because alleles in sexually reproducing organisms are only on the same team for so long, the process of breaking up co-adapted gene complexes, through meiosis and sexual reproduction, creates a paradox. Why, and in what circumstance would natural selection favor the disassembly and random inheritance of different alleles? In addition, sexual reproduction also introduces a cost to the individual (and their constituent genes) in the form of finding a potential mate before reproduction can occur. Both the genetic cost, i.e. the *Cost of Meiosis*, and the individual cost, that of finding a mate, should be addressed in order for a gene-centric hypothesis on the evolution of sex to be satisfactory.

### **The Evolution of Sex**

There are several hypotheses regarding the evolutionary benefits of sexual reproduction. One of the oldest hypotheses is that recombination allows beneficial mutations arising on poor genetic backgrounds to be placed onto chromosomes with better genetic backgrounds (Fisher, 1930). Professional sport teams offer an analogous process. Individual players (alleles) are drafted and placed onto different teams (chromosomes). The process of recombination is similar to one

player being traded for another player from a different team. By trading for a better player (an allele with higher adaptive value), a good team may increase its chance of winning (reproduction) in the following season (selective environment).

On the flip-side of the same coin, recombination also provides a mechanism by which deleterious mutations can be consolidated into one chromosome and removed more efficiently by selection. Both these hypotheses, however, were criticized as they do not address the potential for recombination to also breakup favorable gene complexes and place them onto a poor genetic background: a process that would confound the effects of natural selection, not enhance them (Smith, 1968).

Crow and Kimura provided a response to this criticism by generating a model in which recombination could be advantageous if negative epistasis occurs between different alleles of lower adaptive value (Crow & Kimura, 1965). The model assumes, however, negative epistasis must be present in order for that to occur. Negative epistasis is when two alleles (belonging to different genes) with lower adaptive values, say 0.2 and 0.4 (high adaptive value is closer to 1) are present in the same individual, and the result is an adaptive value lower than the averaged value between them. In this case, negative epistasis would be an average adaptive value lower than  $0.3 [(0.2 + 0.4)/2]$ . Intuitively, positive epistasis would seem to provide a better assumption. However, in a model with positive epistasis between beneficial alleles, recombination would be *disfavored* as breaking up fitness boosting combinations would result in net-fitness loss for that strategy;

consequently, negative epistasis was the only valid assumption at the time that could be used for their model.

As of now, there are two generally accepted (not mutually exclusive) hypotheses that address the evolutionary benefits of recombination and sexual reproduction. One hypothesis proposes that recombination offers an *immediate benefit* to individual fitness. The other proposes that recombination offers a *generative benefit*; that variation in progeny is more beneficial than the cost of finding a partner and the *Cost of Meiosis* combined. Neither hypothesis alone, however, can explain the wide-spread phenomena of sexual reproduction, so both will be presented in this review.

**Immediate benefit hypothesis.** The first hypothesis states that recombination is a beneficial byproduct evolved from the process of DNA repair in single-celled organisms (Michod & Levin, 1988). In bacteria and yeast, the proteins involved in recombination also function as DNA repair proteins, giving this hypothesis credence. DNA repair in bacteria occurs by the pairing of homologous sequences between plasmids (bacterial chromosomes) within one bacterium. Repair proteins bind the two plasmids together at homologous sequences and allow the exchange and replacement of damaged material. If two plasmids are slightly different in sequence structure, then the process of DNA repair actually results in a recombination event (Lewin, 2000). These observations serve as the impetus for the immediate benefit hypothesis, supporting the notion that recombination and crossing over evolved due to an unexpected yet beneficial consequence of DNA repair which increases the survival of cells and their

constituent genes. Accordingly, that benefit then served as the catalyst to reinforce the selective advantage of sexual reproduction when it evolved.

In the same hypothesis, but on a slightly higher level, Koehler, Hawley, Sherman, and Hassold (1996) identified that chiasmata formation, the entwined structure of homologous chromosomes during crossing over, is important for the proper separation of chromosomes during anaphase I in humans and fruit flies (Koehler, Hawley, Sherman, & Hassold, 1996). Several studies confirm this in other organisms, finding significant correlation between the deleterious condition of aneuploidy (uneven chromosome distribution due to errors in chromosome separation) and low levels of chiasmata binding (Baker, Carpenter, Esposito, Esposito, & Sandler, 1976; Engebrecht, Hirsch, & Roeder, 1990). On the opposite end of the cross-over spectrum, too much exchange has been found to correlate with unsuccessful separation of homologous chromosomes (Koehler, et al., 1996; Merriam & Frost, 1964), and is likely due to the difficulties of untangling highly intertwined chromosomes after crossing over (Otto & Barton, 1997).

Both evidences show that recombination events are important to the survival of the organism and its constituent genes. Without proper DNA repair and separation of homologous chromosomes, recombination would have been dangerous for sexual reproduction. The immediate benefit hypothesis develops the contextual origin of sexual reproduction. However, by itself the immediate benefit hypothesis does not explicitly address either concern listed above: that of finding a mate and that of losing genetic material between generations. In order to overcome those costs, the genetic benefit of hybridizing with a unique partner



must supply sexually reproducing genotypes with higher net-fitness. The second hypothesis on the evolution of sex attempts to target that concern specifically. It is generative in nature and in some ways resembles hypotheses for higher levels of selection, something we will cover in latter sections. I will introduce the basis of this hypothesis using an economic analogy, taken from Bell's tangled bank theory (Bell, 1982).

**Generative hypothesis.** In this analogy an economic market represents the pool of alleles individuals select their genes from. The consumer is analogous to an individual that needs a particular product (set of alleles) in order to survive or have better fitness in a given environment. Imagine the market is saturated with only a few products and those products are exceptionally expensive. If the distribution of wealth is such that only a select few can purchase the product, then the capital of that market is at a global minimum. In other words, the market can only support the survival of a few individuals because the expense threshold for the desired product is too high—or the competition among buyers too great. Individuals with lower capital, who do not meet the expense threshold, will be excluded from the economy. Thus, the market's total economic capital is limited by product types and their values. It follows that if the market expands its product types and their respective values (analogous to an increase in genetic variation), then more consumer capital can enter the market. That is to say, if the demands of the consumer base are diverse enough, the market should respond by creating and supplying different product options. Thus, the market represents the pool of alleles of a population and the product it creates explicitly defines the niche of an

individual, or the selective environment in which that individual will have the highest fitness. By diversifying the market through sexual reproduction, a population essentially diversifies the availability of different niches that individuals can acquiesce. But what constitutes consumer demand? Or, to bring the analogy back, what ecological situation would favor a continually variable genome for an organism over generational time?

Heterogeneous or dynamic environmental conditions have been proposed to be the impetus for the generative phenomenon. Whether that means spatially or temporally (or both) has been the source of some debate. In Bell's Tangled Bank theory, the environment or economy is spatially heterogeneous when products are diverse, yet overall remains temporally stable, i.e. the price of a particular gene product remains stable through time (Michod & Levin, 1988; Muller, 1932).

The Tangled Bank theory implies organisms that reproduce asexually have a limited ability to adapt to a changing environment. This can be demonstrated using a modified version of Muller's ratchet (Muller, 1932). Imagine that mutations which form alleles A, B, and C are beneficial to an asexual population that just experienced a change in selective conditions. Mutation A occurs in one individual and begins to spread to fixation in their offspring lines. However, in order to fix B in the population, an organism would already need A, and likewise with C. On the other hand, if this event occurred in a sexually reproducing population, beneficial mutations could arise in separate individuals and in a shorter amount of time, due to meiosis and recombination, end up in the same individual. Essentially, asexual populations are limited, respectively, in their

temporal ability to respond to a change in selective conditions (Michod & Levin, 1988).

A recent study on *Brachionus calyciflorus*, an aquatic rotifer that has the capacity to reproduce both sexually and asexually, has shown that when exposed to spatially heterogeneous conditions, populations cope by shifting to more sexual modes of reproduction (Becks & Agrawal, 2010). Those findings imply that recombination and sexual reproduction may have evolved in response to temporally dynamic or spatially heterogeneous environmental conditions. Or to use economic terms, a sexually derived economy provided better (genetic) options for genotypes than an asexual one during times of change. Whether or not the reproductive strategy of the rotifer is derived or an artifact of evolution can only be speculated; however, it does offer an interesting glimpse into the possible origins of sexual reproduction. Perhaps sexual reproduction was a flexible strategy and not so deterministic.

Other supporting evidence for the generative hypothesis comes from artificial selection experiments. The effect of artificial selection is determined both by the selective pressure (for the desired trait-form) and the heritability of that trait-form. Because artificial selection involves a fair amount of inbreeding, over time the gene pool of a selective group becomes more homogenous. Therefore, even if the selective pressure remains high, the variation of a trait is reduced over time, as well as the group's genetic ability to respond.

Under the generative hypothesis, when exposed to direct selection for a particular trait, populations should respond with an increase in recombination

frequency around the genes that code for the trait under selection. Over several generations that increase will essentially dissociate the allele from the fate of its genetic background, allowing selection to fix the beneficial allele faster in the population. This has been demonstrated both in theory and experiment (Otto & Barton, 1997).

Over a decade ago, Korol and Idiadi (1994) performed an experiment that tested the effect of artificial selection on recombination frequency (Korol & Iliadi, 1994). Their experiment tested the response of population wide recombination frequencies to positive and negative directional selection for the trait geotaxis in *Drosophila melanogaster*. The trait *geotaxis* determines whether a fly prefers to be oriented facing up or down with respect to gravity. Trait-form *geo*<sup>+</sup> prefers upward orientation, while trait-form *geo*<sup>-</sup> prefers downward orientation. Korol and Idiadi found that when exposed to heavy selection, over the course of fifty generations, recombination rates significantly increased around the *geotaxis* loci in both strains of flies, those selected for *geo*<sup>+</sup> and those selected for *geo*<sup>-</sup>. Their experiment provides evidence that change in recombination frequency is either a byproduct of selection for a particular allele, i.e. individuals with higher rates of recombination around that allele produce on average offspring with higher fitness, or that recombination itself can be directly affected by selection, i.e. modifier alleles for recombination frequency exist within the DNA itself.

Through computer modeling on recombinant modifier loci, i.e. loci that directly influence recombination frequency proximal to their location, Otto and Barton (1997) have shown the latter case to be a viable explanation (Otto &

Barton, 1997). Their model demonstrates that modifiers which increase recombination frequency will associate non-randomly with beneficial alleles that are under high levels of selective pressure. Thus, selection can act directly on recombination frequency by increasing the rate of recombination around gene loci that are under direct selection. When one population is under higher levels of selective pressure, we could hypothesize and predict empirically that recombination frequency should be higher in that population relative to another population not under the same selective pressure. I test that hypothesis at the end of Chapter 2.

Does either hypothesis require more than a gene-centric explanation to account for the paradox of sexual reproduction? The first hypothesis is essentially gene-centric in definition, as it would provide an immediate evolutionary benefit to any team of genes equipped with a highly functional system of recombinant DNA repair. The notion, however, that recombination became a beneficial byproduct of the DNA repair mechanism when sexuality evolved, is logically flawed. Granted, it provides correct assumptions about the contextual origin of sexual reproduction, but it does not explicitly address the maintenance. It also does not address the upfront fitness cost of losing genetic material and finding a mate. The cost of finding a partner and the loss of genetic material must have been present when sexual modes of reproduction evolved.

The burden of explanation then falls on the generative hypothesis. Does the generative hypothesis provide any evidence that cannot be explained by gene-centric evolution? I would argue that it does not. The aquatic rotifer provided an

excellent example. Because individual rotifers have the capacity to *choose* their reproductive strategy in a given environment, it could be argued that ultimately their genes are responsible for that decision. Thus, if an allele produces a trait-form that can detect which strategy is better for reproduction in a given environment, than selection would also favor alleles that are better at detecting environmental conditions.

Aquatic rotifers are not the only organisms that possess unique reproductive strategies. In a very extensive review on the subject, Michael T. Ghiselin (1969) provides ample evidence that different forms of hermaphroditism and self-fertilization are relatively common in nature (Ghiselin, 1969), and that most have flexible strategies for reproduction. For instance, after finding a suitable environment in which to grow, some species of fungi go through long periods of asexual or clonal reproduction followed by a relatively short period of meiotic activity and sexual reproduction through spore dispersal. That strategy essentially employs both modes of reproduction temporally depending on the environment, giving gene-centric support to the generative hypothesis.

Due to the nearly countless number of reproductive strategies present in nature, no general statement can be made about the advantage of one strategy over another; especially, because two species rarely share a common selective environment. Because of that, I find the generative hypothesis does the best job at pacifying the two concerns above. It helps to formalize how reproductive strategy is simply derivative of selection on the variability of con-specific genotypes. Questions can be asked from the genotype's point of view: given this environment

and the genes I have, what reproductive strategy ensures my genes are propagated most effectively and have the best chance at survival and replication in the future? Without asking the question anthropomorphically, it still stands that reproductive strategy depends on environmental and selective context, and will be selected for, independent of whether the strategy is beneficial for the group or species (which it may or may not be). Thus, the question should not be: *how did sexual reproduction evolve*, but rather: *in what evolutionary circumstance was sexual reproduction a better strategy for gene propagation than asexual reproduction*.

We have now arrived at the cross-roads between the two apparent caveats of gene-centric evolution. The first, as I demonstrated, was pacified by the generative hypothesis. The two concerns raised earlier were satisfied without sacrificing the integrity of the gene-centric hypothesis. Sexual reproduction evolved from the necessity for genetic diversity in a heterogeneous environment. I will now explore the second caveat, one that continues to be a subject of much debate: social altruism.

### **Social Altruism, Indirect Fitness, and Kin Selection**

Social *interaction* is any interaction or exchange of information occurring between con-specific individuals. Social *behavior* is any social interaction or exchange of information between con-specifics that results in a fitness consequence for both individuals. In a behavioral interaction, one individual is typically defined as the actor, while the other is called the recipient. The *type* of interaction that occurs between an actor and recipient determines the fitness consequence of their interaction.

Generally, there are four *types* of behavioral interactions, each with their own respective consequence. The first type of behavioral interaction is when an actor and a recipient both benefit (in term of fitness) from an exchange; typically this is defined as cooperation. The second is when an actor losses fitness and the recipient gains fitness; typically this is defined as altruism. The third is when an actor gains fitness but reduces the fitness of the recipient; this is called selfishness. And the fourth behavioral interaction occurs when both the actor and recipient lose fitness from the exchange; typically called spite (West, Gardner, & Griffin, 2006).

A cooperative interaction between con-specific individuals needs no elaboration by a gene-centric hypothesis. Any genes related to that behavior will consequently have higher levels of fitness, by definition. The presence of selfishness and spite need no special attention either; as selfish interaction is gene-centric by its very nature (Dawkins, 1989) and spite would be beneficial in terms of reducing future competition—provided you take more fitness from them, than they take from you (Hamilton, 1970).

The presence of altruistic actors in nature, or any behavior that increases the reproductive output of others at the expense of personal reproductive output, presents a formidable challenge to the gene-centric view of evolution. Altruism, if it truly does exist, completely violates all principles. Any allele that provides an actor with the propensity for self-sacrifice in order to boost the reproductive good of a recipient should, in no circumstance, ever be *advantageous* over more selfish forms of that gene.



For example, imagine a herd of antelope consistently preyed upon by a pack of lions. Suddenly, a gene arises by mutation that bestows one of the antelopes with the intention of self-sacrifice when the herd is in danger. Upon attack, the selfless antelope dashes in front of the pursuing lions, quickly falling victim while the rest of the herd escapes. Following its heroic and altruistic sacrifice, the antelope and its altruism-inducing mutation would be lost from the breeding population. From this rather extreme example, it would seem that altruism must be exceptionally rare in a biome evolving by natural selection. However, there are plenty of empirical examples of apparent altruism in nature.

The most pronounced case of apparent altruism comes from the sterile worker caste in eusocial insects. The presence of worker phenotype seems to defy the very nature of “survival of the fitness”. How could an allele for sterility ever become common in a population? It is *prima facie* paradoxical. Even Darwin himself recognized the presence of sterile caste in ants as *fatal* to his theory (Darwin, 1859).

In the mid-twentieth century many models were constructed by theoreticians to explain how alleles that code for altruistic-like behaviors could increase in a population (Williams, 1966; Wynne-Edwards, 1962). Some models invoked hypotheses for selection on the group: if altruistic members within a group enhance the entire groups’ fitness on average (relative to groups without altruists), then alleles for altruism could increase in frequency.

Counterarguments against group selection came from prominent mathematicians and theoreticians such as W.D. Hamilton, John Maynard Smith,

G.C. Williams, and later Richard Dawkins (Dawkins, 1989; Hamilton, 1963; Smith, 1964; Williams, 1966). They argued that group selection need not be invoked to explain the presence of altruistic behavior in social groups. Hamilton argued, especially in the case of social insects, that if colony members were related enough, then individuals who sacrifice their reproductive right could still gain fitness, albeit indirectly, by enhancing the fitness of their close relatives around them by foraging or participating in colony maintenance. Hamilton called this *inclusive fitness* (Hamilton, 1964a, 1964b). Later Maynard-Smith expanded the inclusive fitness definition, calling it *kin-selection* to explain the presence of seemingly altruistic behaviors in other less-socially developed organisms—e.g. mother birds feigning injuries to draw predators away from their nests (Smith, 1964).

The equation for inclusive fitness (and kin selection), as given by Hamilton, is presented here in its simplest form:  $rb - c > 0$ . Where  $r$  = relatedness between the actor and recipient,  $c$  = fitness cost to actor, and  $b$  = direct fitness benefit gained by the recipient. If the relatedness between the actor and recipient is high enough ( $r > 0$ ), provided the net fitness benefit bestowed on the recipient outweighs the gross (fitness) cost of the action, than an allele for altruistic behavior will increase in frequency. The largest assumption of inclusive fitness is, at the very least, both the actor and the recipient *must* share the allele that codes for altruistic behavior. This is also implicit in Maynard-Smith's kin-selection theory. The offspring of the mother bird feigning injury *must* carry the allele for distracting predators in the presence of kin.

We must now address the question of whether Hamilton's inclusive fitness (gene-centric) theory, or any derivative, provides enough evidence to support the presence of *all sterile workers* in eusocial Hymenoptera. I choose the order Hymenoptera as it contains most of the commonly recognized eusocial insects, e.g. bees, wasps, and ants; all of which exhibit haplo-diploid reproductive systems. As the order Hymenoptera contains within it my system of study, *Pogonomyrmex rugosus* and *Pogonomyrmex barbatus*, I will use a narrative that best describes *Pogonomyrmex*; although many systems in Hymenoptera follow the same, if not very similar mechanisms.

### **Eusociality in *Pogonomyrmex***

Eusociality in *Pogonomyrmex* is characterized by a reproductive division of labor, cooperative brood care, and overlapping generations (Lin & Michener, 1972). Reproductive ability in females is compartmentalized into phenotypically distinct individuals, typically called gynes. Gynes are winged, diploid, usually larger than workers, require more resources to develop, and do not participate in colony maintenance or growth. Workers are diploid, wingless, smaller than gynes, typically cost less resource to develop, develop without functional reproductive organs (at the very least they are underdeveloped ovaries), and spend much of their life foraging, contributing to colony maintenance, and rearing larvae. Males in *Pogonomyrmex* are haploid, develop from unfertilized eggs, are produced just prior to the mating season, and do not contribute to social colony life. Because males in *Pogonomyrmex* lack social-skills, Bert Hölldobler, a prominent

researcher on social insects, has gone as far as to call them “sperm-bullets” (personal communication).

Eusocial insects are unique in that most have overlapping generations. Worker offspring stay in the nest and support the colony for their entire life. During early development, colonies produce many workers to aid in colony stabilization and growth. Once colonies are mature (after about five years), stable, and able to handle the resource drain of producing gynes and males, they will produce new sexual reproductives each mating season continually until the queen’s ovaries run dry; which may take up to fifteen years (Gordon & Kulig, 1996).

As mentioned before, the presence of worker sterility presents an immediate problem, not just to the gene-centric hypothesis, but to the entire theory of natural selection. In order to mitigate this concern, Hamilton knew that workers and reproductives must *at the very least* share the alleles for sterility. Truthfully, in order to have a viable and competitive colony in every generation, the worker phenotype must be continually propagated through the genotype of reproducing individuals. Because two very different phenotypes are present which must share nearly the same genotype (according to inclusive fitness), this must be a case of phenotypic plasticity.

Phenotypic plasticity is currently the best explanation for the presence of worker phenotypes and has been confirmed by several empirical studies (reviewed in (Queller & Strassmann, 1998). Generally, worker and gyne phenotypes are differentiated by the developmental environment during critical

stages of larval growth (Wheeler, 1986). The quality and quantity of allocated resource to developing larvae dictates the direction of their development. That mode of caste development is called environmental caste determination (ECD). As gynes impose higher resource costs than workers and do not contribute to colony maintenance and resource acquisition, tight control over their temporal production is paramount for colony fitness (K. E. Anderson, Hölldobler, Fewell, Mott, & Gadau, 2006; T. Schwander, Cahan, & Keller, 2006).

Given the above arguments, alleles favoring larva to develop into gynes despite environmental cues to do otherwise would immediately have higher fitness and should spread rapidly throughout a population (Hölldobler & Wilson, 2009). This mode of caste determination, that uses alleles to specify reproductive caste, will be called genetic caste determination (GCD). In a colony with both modes of caste determination, larva with alleles that only respond to ECD would lose fitness. Their chances of developing reproductive capacity would be diminished in the presence of excess gynes and decreased colony productivity. Because colony fitness depends on a strong altruistic workforce, selfish gyne-determining alleles would disrupt the otherwise balanced ratio of castes within a colony. Thus, according to gene-centric views on evolution, caste influencing alleles or modes of genetic caste determination (GCD) would be unfavorable to colony fitness and should not be considered an evolutionary stable strategy for eusocial colonies (Smith & Price, 1973). In order to balance reproductive conflict within a colony, workers and reproducing individuals should be equally related. Any evidence to the contrary has been of special interest to evolutionary science.

## Reported Associations of Alleles and their Influence on Caste

Recent advance in molecular science, with the understanding that genetics of both phenotypes should be explored, has begun to elucidate the role of genes in determining caste and phenotypic trait expression. The first case of suspected genetic association with caste was reported in the stingless bee, *Mellipona marginata* (W.E. Kerr, 1950a; Warwick E. Kerr, 1950b). Based on a stable 3:1 ratio of workers to gynes in *M. marginata*, Kerr proposed a two loci model—where two independent genes affect caste. In this case genes A and B would have two alleles each (e.g. A,a and B,b, respectively). In his model, heterozygosity at both caste-determining loci would result gyne development (AaBb). Therefore, as males are haploid and the product of meiosis, heterozygous queens should produce both males and eggs with genotypes AB, aB, Ab, and ab, respectively. Any fertilization between two gametes should produce workers and gynes in a 3:1 ratio. Workers would develop from homozygosity at one loci or both (aabb, aaBb, Aabb, AAbb, aaBB, AABB), and for farther clarification see *Table 1*. Notably, Kerr also reported variable ratios in times of winter, poor nourishment, and presence of parasites; insinuating that environmental quality is still an underlying factor for gyne development in *marginata* and other *Mellipona* bees (W.E. Kerr, 1950a; Warwick E. Kerr, 1950b).

		Queen Alleles			
		AB	Ab	aB	ab
Male Alleles	AB	AABB	AABb	AaBB	<b>AaBb</b>
	Ab	AABb	AAbb	<b>AaBb</b>	Aabb
	aB	AaBB	<b>AaBb</b>	aaBB	aaBb
	ab	<b>AaBb</b>	Aabb	aaBb	aabb

*Table 1. Hypothetical Caste Determination in Mellipona.* The table above represents the hypothetical mode of caste determination in *Melipona* as proposed by Kerr. All queens are presumed heterozygous at both loci; therefore, male sperm would contribute an identical set of gametes as those produced by the queen, leading to a 3:1 worker to gyne ratio on average. Queen genotypes are shown in bold.

The next case of allele association with caste phenotype comes from the South American red fire ant, *Solenopsis invicta*. *Solenopsis invicta* is known to have two distinct populations or social forms in terms of queen number within each colony. One population has only mono-gyne colonies: one egg laying queen per colony. The other population consists of poly-gyne colonies: multiple egg-laying queens per colony. Both populations share common geographic borders, and males from mono-gyne colonies are routinely found in poly-gyne mating flights. In poly-gyne colonies, maturing gynes homozygous for allele Gp-9<sup>B</sup> (diploid representation would be: Gp-9<sup>B/B</sup>) are prevented from laying eggs and are typically attacked and killed by workers before they reach reproductive maturity. Consistent gene flow from males of monogyne colonies (where the allele Gp-9<sup>B</sup> is fixed) maintains high presence of Gp-9<sup>B</sup> in the poly-gyne population (Keller & Ross, 1999; Ross & Keller, 1995). Interestingly, when the allele Gp-9<sup>B</sup> is in its homozygous form it increases the rate of reproductive maturation in developing gynes. Even more interesting is that allele Gp-9<sup>b</sup> allows heterozygous gynes (Gp-

$9^{B/b}$ ) to be *accepted* in poly-gyne colonies. Therefore, gynes that are heterozygous for both alleles are allowed to mature and reproduce unabated. That case demonstrates the ability of workers in poly-gyne colonies to affect population-level allele frequencies by detecting and culling (killing) aberrant genotypes (homozygous for  $Gp-9^B$ ) before they develop reproductive capacity; effectively keeping the  $Gp-9^B$  allele from monopolizing poly-gyne colonies. The ability of *S. invicta* workers to detect and cull larva based on genotype implies that other species of ants, particularly those affected by GCD, may employ similar behaviors toward genotypes composed of *cheating* alleles. Those behaviors would help boost colony productivity by removing unwanted genotypes (gynes) during early colony growth, when a strong workforce is vital.

Recent experiments on the fire ant *Wasmannia auropunctata*, a species known to exhibit both *clonal* and *sexual* reproduction strategies, have detected vast differences in the mechanism of caste determination between both colony types (Foucaud, Estoup, Loiseau, Rey, & Orivel, 2010). Sexually reproducing colonies, whose queens fertilize all their eggs with sperm, exhibit normal allele frequencies between workers and gynes. However, queens from clonal colonies produce new gynes by a process called thelytokous parthenogenesis: an unfertilized diploid egg is laid and develops into a gyne; essentially, a case of asexual reproduction. Thus, gynes produced from those colonies are direct clones of their queen. Unlike their reproductive siblings, workers in clonal colonies develop from fertilized eggs and share a common patriline (father). Males from clonal colonies are still haploid, yet they are not created through normal



arrhenotokous parthenogenesis (laying of an unfertilized egg) as reported in sexually reproducing colonies (Foucaud, et al., 2010). Males are created when haploid sperm from the father *displaces* the genetic material of the egg, and a new haploid male develops. Males in clonal colonies are essentially clones of their fathers (outside of their mitochondrial DNA, which is always inherited from the mother). Functional genetic isolation between males and queens in clonal colonies presents an interesting paradox of both genetic and sexual conflict. Essentially, both sexes are evolutionarily separate, yet both must be present and compatible to create workers. The mechanisms surrounding the stability and evolution of that system have yet to be fully elucidated.

In the Southeast Asian ant *Vollenhovia emeryi*, extreme genetic differences have been reported between sympatric (geographically co-occurring) populations exhibiting two distinct wing-phenotypes, respectively; short wings, S-wings, and long wings, L-wings (Kazuya Kobayashi, Hasegawa, & Ohkawara, 2008; K. Kobayashi, Hasegawa, & Ohkawara, 2011). Gynes from the same colony all exhibit the same wing-type, and no instance of both wing-types in one colony has yet been reported (K. Kobayashi, et al., 2011). Those observations alone imply some level of genetic isolation exists between the two populations of different wing-types.

Several microsatellite (MS) markers were found to segregate non-randomly with caste in the S-winged colonies. Microsatellites are heritable regions of repetitive DNA sequence that vary in respective length throughout a population. They do not code for a particular trait-form, but they are useful for

detecting correlations between heritable trait-forms (such as wing size) and particular regions of DNA. If a MS marker is located proximal to a gene that codes for a particular trait, then correlations can be made between MS lengths and different trait-forms—even when the responsible genes have not yet been identified. In *V. emeryi*, gynes were found to be homozygous for those MS markers, while workers were almost exclusively heterozygous, showing immediately a relationship exists between allele and caste. In *V. emeryi*, S-winged workers develop from fertilized eggs. S-wing gynes and males, however, arise from process similar to *W. auropunctata*, where gynes are produced by thelytokous parthenogenesis and males are clones of their father. No recent gene flow has been detected between S-males and S-gynes, empirically verifying that genetic isolation exists between both sexes. Whether similar mechanisms exist within the L-winged colonies has yet to be determined (Kazuya Kobayashi, et al., 2008; K. Kobayashi, et al., 2011).

In the polyandrous ant *Cataglyphis cursor* (queens mate with more than one male), orphaned workers compete amongst themselves to replace an absent queen by laying thelytokous parthenogenic (clone) eggs. Very few of those eggs actually develop into gynes due to competition and strong potential for egg destruction among workers (Clémencet, Rome, Fédérici, & Doums, 2008). As *C. cursor* is a polyandrous species, many patriline are present across workers in a single colony. Recently, Chéron et al. (2011) tested whether patriline was correlated with successful gyne development (queen replacement). Using large numbers of workers and newly produced gynes from thirteen orphaned colonies

(queen removed), Chéron et al. found significant correlation between worker patriline and successful gyne development in over half of the colonies sampled. To some degree their study implies patrilines in *C. cursor* exhibit a type of *royal cheating* and bestow workers with an added genetic propensity to lay viable (clone) eggs; thereby, increasing their individual fitness posthumously (Chéron, Monnin, Fédérici, & Doums, 2011). The presence of genetic cheating in patrilines of *C. cursor* is testament to the selective pressure for individuals to maximize their fitness within the boundaries of a highly eusocial group.

### **The *Pogonomyrmex* Dependent Lineage System**

In the last decade, two unique populations of species *Pogonomyrmex rugosus* and *Pogonomyrmex barbatus* were identified, each exhibiting a special case of genetic caste determination (GCD). Both species are haplo-diploid, polyandrous, and reproduce once a year, timed in perfect synchronicity the day following the first heavy annual monsoon rain (typically requires more than 1” within a 24 hour period: personal observation). Evidence suggests that each species contains one population of two genetically isolated, yet mutually obligate lineages (Sara Helms Cahan et al., 2002; G. E. Julian, Fewell, Gadau, Johnson, & Larrabee, 2002; Volny & Gordon, 2002). Each population of GCD is genetically isolated from their ECD relatives; hence, they do not exchange alleles. Those lineages have been labeled H1 and H2 in *P. rugosus* and J1 and J2 in *P. barbatus*. H1 and H2 lineages appear phenotypically indistinguishable from ECD *P. rugosus* and range from southern Arizona to western Texas; while J1 and J2 lineages appear in mid-Arizona and range through southern New Mexico and

parts of western Texas and are phenotypically indistinguishable from ECD *P. barbatus*. ECD populations of both species extend within and beyond the geographic overlap: ECD *P. rugosus* covers more northern territories, into California and Nevada, while ECD *P. barbatus* expands its territory through the hotter and more arid parts of eastern Texas and south into central Mexico (K. E. Anderson et al., 2006; Tanja Schwander, Cahan, & Keller, 2007)

GCD in *Pogonomyrmex* behaves in the following manner: queens of one dependent lineage, for instance H1, produce workers by fertilizing their eggs with sperm from an inter-lineage male; in this case H2 (by chance not by choice). Therefore, worker genotypes are hybrids of the two lineages (H1/H2) and they do not reproduce. Gynes develop from eggs fertilized with the sperm of an intra-lineage male (H2/H2), and males in this system are created by normal arrhenotokous parthenogenesis (develop from unfertilized eggs) and possess only maternal, intra-lineage alleles. GCD gynes are obligatorily polyandrous, and depend on both intra and inter-lineage matings to start viable and reproductively capable colonies. As the dependent lineages in both species are visually indistinguishable from their ECD counterparts, they will be delineated based on their lineage (H1, H2, J1, or J2) or mode of caste determination (GCD or ECD).

### **Genomic Evidence for GCD**

Individual DNA (from all castes) collected from both GCD populations has been analyzed using protein electrophoresis, micro-satellite markers (MS), AFLPs, and universal mitochondrial markers (K. E. Anderson, Holldobler, et al., 2006; S. H. Cahan & Keller, 2003; G. E. Julian, et al., 2002; Tanja Schwander,

Cahan, et al., 2007; Sirviö, Pamilo, Johnson, Page, & Gadau, 2011; Sirvio, Pamilo, Johnson, Page, & Gadau, 2011; Volny & Gordon, 2002). Protein electrophoresis is performed by isolating a specific gene product (protein) from individuals sampled from multiple populations. The isolated protein is denatured (heated) and then placed in a charged gel, allowing it to fully extend. Protein lengths are then analyzed to show population wide variation of a particular gene. AFLPs are DNA fragments resulting from the work of restriction enzymes. Restriction enzymes work like genetic scissors, scanning the DNA and cutting it at specific target sequences (normally about 6 – 12 base pairs in length, depending on the enzyme). The length of DNA between cuts is compared amongst different populations to determine genetic differences at a larger but less accurate scale. Mitochondrial DNA, as mentioned earlier, is transferred directly from mother to offspring. Mitochondrial markers are simply mitochondrial gene sequences (mtDNA) that are shared between very diverse organisms. Change in mitochondrial gene sequence occurs much more slowly and consistently, compared to nuclear DNA. Therefore, any difference between separate populations is usually on the order of one or two nucleotides (base pairs) per marker. Mitochondrial markers are useful in accurately predicting the time of genetic divergence between isolated populations and in creating evolutionary relationships between multiple samples.

Of the nuclear markers sampled, several have been shown to segregate significantly with caste. Nearly all workers were found to be heterozygous at these loci, while their reproductive counterparts were almost exclusively

homozygous at the same loci. Because intra-lineage males fertilize intra-lineage eggs to produce intra-lineage gynes, males share many of the same alleles as their sister gynes; therefore, when heterozygosity is seen only in workers, it implies that inter-lineage sperm was used to fertilize those eggs.

Further studies have illuminated the phylogenetic (evolutionary) history of GCD in the two lineages of *P. rugosus* and *P. barbatus* (K. E. Anderson, Gadau, et al., 2006; Sirviö, et al., 2011; Sirvio, et al., 2011). As both males and gynes are descended from a single mother, every reproductive individual in each lineage shares a common mitochondrial genome with their reproductive siblings. Because reproductive capacity is necessitated by intra-lineage matings, all members of one lineage are of one mitochondrial origin, provided strict genetic isolation exists between lineages.

Both nuclear and mitochondrial evidences point to sympatric hybridization between ECD *P. rugosus* and ECD *P. barbatus* as the mechanism involved in the evolution of all dependent lineages (K. E. Anderson, Gadau, et al., 2006; S. H. Cahan & Keller, 2003; G. E. Julian, et al., 2002; Linksvayer, Wade, & Gordon, 2006; Tanja Schwander, Suni, Cahan, & Keller, 2008; Sirviö, et al., 2011; Sirvio, et al., 2011). The genome of each lineage appears to be a mosaic of both parental species, containing alleles from each species. The representative amount of parental alleles in each lineage has been estimated by Schwander et al. (2007a) and Sirviö et al. (2011) and is depicted visually in Figure 1 (Tanja Schwander, Cahan, et al., 2007; Sirviö, et al., 2011). Schwander et al. employed nine micro-satellite markers to make an estimate of parent species allele contributions for all

lineages, while Sirviö et al relied on 1147 AFLP markers for their estimates. Both estimates were taken into account when constructing Figure 1.

Although both nuclear and mitochondrial markers have been shown to segregate with caste in lineages of GCD (K. E. Anderson, Gadau, et al., 2006), conflict still exists over which genome technically diverged first; nuclear or mitochondrial (K. E. Anderson, Gadau, et al., 2006; Sara Helms Cahan, Julian, Schwander, & Keller, 2006; S. H. Cahan & Keller, 2003; Tanja Schwander, Cahan, et al., 2007). Mitochondrial genomes do not recombine; therefore mitochondrial origin can be determined by tracing lineage specific mitochondrial sequences back to the mitochondrial sequences of the two ECD parental species. Genome divergence is tested heuristically using neighbor joining methods (least amount of sequence difference between samples) in order to develop the most probable phylogenetic model. Such a model has been constructed and surprisingly depicts the common mitochondrial origin of H1, H2, and J2 lineages to be of ECD *P. barbatus* descent, while the J1 lineage joins parsimoniously with ECD *P. rugosus* (see Figure 1) (Sirviö, et al., 2011).

Phylogenetic models constructed for the nuclear origins of each lineage tell a different story. In the most current estimate, Sirviö et al (Sirviö, et al., 2011) employed 1147 nuclear AFLP markers to separate and cluster individuals sampled from all lineages on the basis of pair-wise difference; a process called principle component analysis (PCA). That process returned shared genetic histories between ECD *P. barbatus* and the H2 and J2 lines; while H1 and J1 were similarly traced to ECD *P. rugosus*. However, due to the nature of hybrid

genomes and the reliability of AFLP based estimates, AFLP markers may not provide the best metric of phylogenetic relationships. Despite that, earlier estimates of phylogenetic origin based on microsatellites and protein electrophoresis are in agreement with the tree proposed by Sirviö et al. (K. E. Anderson, Gadau, et al., 2006; S. H. Cahan & Keller, 2003; Sirviö, et al., 2011).

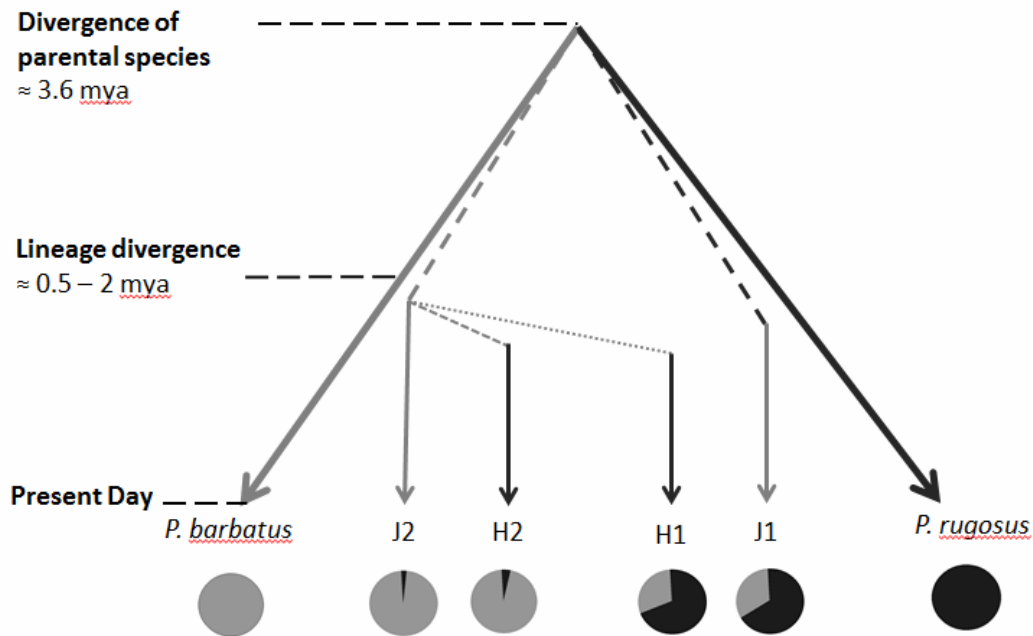

Figure 1. Lineage Divergence from Parental Species. In the above figure, dotted lines represent mitochondrial phylogeny while grey scales depict morphology: *P. rugosus* = dark grey and *P. barbatus* = light grey. The pie-charts below each population label represent the proportion of each parental species' alleles estimated for each lineage after the literature.

### The Costs of GCD

GCD has been demonstrated in laboratories to impose several fitness costs, particularly during early stages of colony growth (K. E. Anderson, Holldobler, et al., 2006; T. Schwander, et al., 2006). Due to indiscriminate sperm use when fertilizing eggs (Clark, Anderson, Gadau, & Fewell, 2006), it has been hypothesized that GCD would inflict a large resource drain on the colony due to



the disproportionate amount of gynes present at colony founding. As gynes require more nutrition to develop than workers and do not contribute to colony growth or maintenance, eggs fertilized with intra-lineage sperm should be considered a resource drain for young GCD colonies. Likewise, gynes produced outside the normal mating season would also inflict a drain on colony resources.

In addition to the upfront costs of unregulated gyne production, disproportionate lineage frequencies within mating swarms could negatively affect both lineages as well. During mating flights, gynes from the more frequent lineage would be less likely to acquire sperm from the less frequent lineage and hence, be less likely to develop a workforce upon colony founding. Conversely, rare-lineage gynes would also be challenged to find intra-lineage sperm. With only inter-lineage sperm to fertilize eggs, rare-lineage colonies would not be able to produce gynes when the colony matures. In the case of those rare-lineage colonies, male production would be the only possible method of reproductive contribution. As a consequence, local mating swarms would reflect disproportionate frequencies of rare-lineage males. Due to the frequency-dependent nature of GCD in *Pogonomyrmex*, it becomes intuitive that selection would favor population frequencies of both lineages to balance around fifty percent; thus, providing a mechanism for the stability and maintenance of that system (K. E. Anderson, Holldobler, et al., 2006).

### **Current models for GCD in *Pogonomyrmex***

Due to its puzzling nature, the presence of GCD in *Pogonomyrmex* populations has merited the contribution of several theoretical models, each

attempting a parsimonious explanation for the genetic basis, evolution, and maintenance of GCD in *Pogonomyrmex*. Of the proposed models only three have remained somewhat viable for this review. From here the models will be presented chronologically, as they appeared in the literature; criticisms of each will then follow.

The first and simplest model, proposed by Volny and Gordon (2002), proposes a single-gene two allele caste-*influencing* locus exists (gene: *caste*, alleles: *4* and *X*). Their model questions the assumption that caste was initially determined by genotype. Much like *Solenopsis invicta*'s Gp-9<sup>B</sup> allele, their model assumes that certain genotypes were initially culled by workers mediating larval development; i.e. workers culled heterozygous individuals from developing into gynes and homozygous genotypes from developing into workers. Their model proposes the origin of GCD occurred by a genetic mutation turning allele *4* into allele *X*, and that *X* influenced the propensity of homozygous genotypes (*X,X*) to become gynes, much like the Gp-9<sup>B</sup> allele in *S. invicta*. In selective response to that cheating mutation, wild-type colonies (queen genotype: *4,4*) nurtured homozygous genotypes (*4,4*) to become gynes while suppressing heterozygous genotypes (*4,X*) to develop as workers. Eventually, both forms of the caste allele became fixed in two populations. Those lineages then became interdependent, i.e. sperm from each lineage would be used by the other to create a workforce. According to their model, worker genotypes in both lines are heterozygous (*4,X*), while homozygous genotypes (*4,4* or *X,X*, respectively) develop as gynes. Because queens would need sperm from both lineages to be successful, Volny and

Gordon also suggest that GCD may be correlated to the evolution of polyandry in *P. barbatus* and *P. rugosus* as well as other polyandrous species of hymenoptera (Volny & Gordon, 2002).

The second model, slightly more complex, starts from the premise that GCD is a direct consequence of hybridization between ECD *P. barbatus* and ECD *P. rugosus* (S. H. Cahan & Keller, 2003). According to their model, GCD exists as the manifestation of incompatibilities between two interacting nuclear loci and is based upon the classic Muller-Dobzhansky hybrid model: AABB (*rugosus*) x aabb (*barbatus*). Inbreeding among F<sub>1</sub> hybrids and their offspring—AaBb (gyne) x Ab (male) x aB (male)—could eventually form genotypes aaBB and AAbb. In this model, inverse-homozygous genotypes (aaBB or AAbb) are developmentally fixed and become gynes, defining each lineage, while double heterozygous genotypes would be developmentally fixed to become workers (AaBb). For instance, mating between a gyne of one lineage (aaBB) and two males of different lineages (aB) x (Ab), would yield both double heterozygous workers (AaBb) and inversely homozygous gynes (aaBB), respectively. The same is also true for gynes from the other respective lineage (AAbb). The viability of this model is dependent on heterozygous individuals (AaBb) capably developing as gynes (and reproducing) when the system originated. Eventually those heterozygous genotypes were suppressed from developing into gynes in the presence of more gyne-biased genotypes (aaBB or AAbb) and that reinforcement became genetically fixed.

The third model, called cytonuclear epistasis (Linksvayer, et al., 2006), proposes that cytoplasmic interactions between diverging mitochondrial and nuclear genomes played a significant role in the establishment of the dependent lineage system. Their model proposes an additional factor (the mitochondrial type) plays a more significant role in lineage specification and caste determination. Like the second model, cytonuclear epistasis also incorporates a hybrid origin to the lineages. In this model, the parental genotypes are assumed to be separate and ancestral to each lineage (ECD *P. rugosus*:  $AA/M$ , and ECD *P. barbatus*:  $aa/m$ ). Alleles  $A$  and  $a$  represent nuclear alleles, while  $M$  and  $m$  represent mitochondrial alleles. After hybridization, each lineage derived their own genotype similar to their respective parental species (e.g. J1:  $A^*A^*/M^*$ , J2:  $a^*a^*/m^*$ ). Much like the first model, their model assumes that a single gene, two allele, caste influencing locus exists for each lineage (i.e.  $A^*$ ,  $a^*$ ). This locus also interacts with the cytoplasm of a specific mitochondrial-type for each lineage ( $M^*$ ,  $m^*$ ). Genotypes of intra-lineage gynes would be:  $A^*A^*/M^*$  or  $a^*a^*/m^*$ , respectively, while inter-lineage worker genotypes could be either of the following:  $A^*a^*/M^*$ ,  $A^*a^*/m^*$ . Homozygosity between mitochondrial and nuclear alleles is required for gyne development while heterozygosity of any type would develop a worker phenotype. Because the mitochondrial type is important for lineage specificity and is inherited through the queen, this model allows for mitochondrial-types to be continually associated with the same lineage. Currently, this model provides the best explanation of GCD maintenance, incorporating the discovery of divergent mitochondrial phylogenies for all dependent lineages.

## Critique of the Models

Although the models above display varying degrees of elegance and simplicity, gaps or errors exist within each line of reasoning, and some issues remain unanswered that were never addressed at all. The models presented above were constructed from an inclusive fitness perspective, and are based on the genotypic fitness of related individuals within a colony. All the models assume that simple genotypic selection stabilizes the system of GCD. I would argue that selection at the colony and population level is *the only logical mechanism that can fully explain the stability of GCD*, something I intend to defend rigorously at the end of Chapter 2. But first I must address the gaps left behind in each model.

The first model, though parsimonious and conservative in nature, violates a key-principle of inclusive fitness in its assumptions: why were homozygous genotypes kept from developing into worker phenotypes? Inclusive fitness would not have favored that strategy. Understandably genotypic selection on a pure-lineage queen would favor her colony to suppress heterozygous larvae from developing gyne-phenotypes, as those larvae would be less related to the pure-lineage queen than eggs fertilized with intra-lineage sperm. But to keep homozygous larva from developing into workers would be an unnecessary fitness cost, as they would provide indirect fitness to their own genotype through maintenance and resource acquisition. In cases of skewed lineage frequencies in a population (see Costs of GCD) where one lineage is over-represented, most of those gynes would mate with intra-lineage males, and as a result, new colonies would only be able to produce gynes and not workers. Selection by inclusive

fitness would favor homozygous genotypes to retain phenotypic plasticity in order to boost the fitness of their closely related gyne-siblings when the queen has only intra-lineage sperm. However, because little to no worker phenotypes have been observed in new colonies of pure-lineage matings (K. E. Anderson, Holldobler, et al., 2006), it stands that heavy selection or *genetic barriers* remain in place against homozygous individuals developing into workers (see Chapter 2); even when faced with colony starvation.

Secondly, by what mechanism did introgression of two different species' alleles occur within each lineage's genome? At the time the model was developed the authors were not aware or refused to acknowledge evidence of the lineages' hybrid genomes. Therefore they did not incorporate an ability to adapt this information to their model. They assumed a mutation at the *caste* gene spread rapidly throughout the ECD *P. barbatus* population, creating dependent lineages, but they fail to specify how both species ended up with two populations of GCD lineages if introgression was avoided by suppressing heterozygous genotypes from developing into gynes. Did a mutation occur in the same genomic region for both species, independently? The odds would be astronomically small.

Current data suggest alleles from ECD *P. rugosus* and ECD *P. barbatus* genomes were pieced and parceled into the dependent lineages while gene flow was still occurring between the hybrid populations and the ECD parental populations (Kirk E. Anderson, Novak, & Smith, 2008; S. H. Cahan & Keller, 2003; Tanja Schwander, Cahan, et al., 2007; Sirvio, et al., 2011). It appears that continual hybridization created GCD populations in both species (K. E. Anderson,

Gadau, et al., 2006). I will defend that position in Chapter 2, but for now we can assume that the dependent lineage system is not controlled and did not originate by a single mutation at a caste influencing locus independently arising in two species; rather, GCD evolved as a direct or indirect result of hybridization between two sympatric species.

The second model, based on the classic Muller-Dobzhansky model of hybrid speciation, assumes that heterozygous individuals (from the hybridization of two species) initially maintained phenotypic plasticity for worker and gyne phenotypes, yet eventually lost that plasticity due to genetic drift. Although the authors do not explicitly state this assumption, genetic drift is implied by their model to have facilitated the loss of phenotypic plasticity in heterozygous genotypes, as natural selection can only affect heritable genotypes. Once the lineages were established (gyenes were developmentally fixed by genotype), the phenotypic plasticity of heterozygous larvae would have been exploited by the colony. In the presence of excess gyne-development, heterozygous genotypes would be shunted to develop worker phenotypes. As the genotype of the worker would no longer be heritable, natural selection could not reinforce the plasticity of that genotype to also include the gyne phenotype. Therefore, according to this model (which is gene-centric), the fixed worker-phenotype developing from a heterozygous genotype would be the result of drift and not selection. However, I interpret the loss of phenotypic plasticity not be a case of genetic drift, but rather a case of selection on colony and lineage fitness. I will elucidate the theoretical component to this claim in the conclusion of Chapter 2.

The second model also fails to address the evolutionary evidence of separate mitochondrial and nuclear divergence: Why do the H1 and H2 lineages have the same mitochondrial origin, yet different nuclear origins? As mentioned in the previous paragraph, Anderson et al (2006) proposed that GCD evolved first in the J2-lineage, followed by a separate hybridization with *P. rugosus* leading to the establishment of the alternate J1 lineage. Eventually J2 out-crossed again to form both H-lineages. If Anderson is right about the origin of GCD, then the Muller-Dobzhansky model of hybrid speciation must have occurred independently each time J2 hybridized with an ECD population. Thus, the mechanisms described in the previous paragraph (loss of phenotypic plasticity in both genotypes) happened independently on three separate occasions, resulting in the same exact system of GCD in all four lineages.

The third model is an expansion of the first, and plays a hat-trick with the second, switching one of the two nuclear genes (B) to a mitochondrial gene (M). The model proposes mitochondria and hence cytoplasm should be considered important to caste determination and GCD lineage evolution. This model, as well as the others, does not fully explain why the H1 and H2 lineages appear phenotypically like ECD *P. rugosus* yet they both have an ECD *P. barbatus* mitochondrial origin. If nuclear-cytoplasmic interactions were the driving force behind the initial separation of the lineages, then the H1 lineage could not share its mitochondrial origin with the H2 or J2 lineage as their nuclear/cytoplasm genes would have been mismatched and gyne development should not have been possible.



Their model also fails to address the presence of gyne phenotypes arising in rare-lineage colonies that have only inter-lineage sperm. In several reports, rare-lineage colonies have successfully produced gynes with inter-lineage genotypes (K. E. Anderson, Holldobler, et al., 2006; Sara Helms Cahan, et al., 2006; Sirvio, et al., 2011). With no evidence of gene flow occurring between lineages, those gynes either suffer post-zygotic isolation (even after successful matings they cannot start viable colonies) or pre-zygotic isolation (cannot successfully mate).

Not one model fully addresses the mechanism of sympatric isolation between GCD populations and their respective ECD parental populations. That isolation cannot be trivial. There must have been gene flow with ECD populations before there was isolation, so why and how did it suddenly stop? Moreover, it must have been advantageous, in terms of genotypic fitness, to interbreed within and between hybrid groups than to outbreed with the parent species. That advantage needs further clarification in order for any model to be satisfactory.

In the following chapter I present a newer and simpler model, pacifying the concerns I raised about the models above. After elaboration of that model, I present empirical evidence supporting a hypothesis for how each lineage has dealt with the problem of inbreeding.

## Chapter 2

### A THEORETICAL AND PRACTICAL APPROACH TO UNDERSTANDING THE EVOLUTION OF GENETIC CASTE DETERMINATION

Most eusocial insect colonies exhibit a reproductive division of labor and alter developmental environment (e.g. nutrient thresholds, humidity, and temperature) to determine which larvae will develop as workers and which will develop as virgin queens (gynes). Generally, larvae fed above an arbitrary threshold will develop as gynes, while larvae that are fed below that threshold develop as sterile workers. This form of caste determination, called Environmental Caste Determination (ECD), ameliorates genetic conflict within colonies by distributing relatedness equally between sterile workers and reproductives.

Recent studies on two species of seed harvester ants, *Pogonomyrmex rugosus* and *Pogonomyrmex barbatus*, have revealed that distinct populations within each species exhibit a unique form of caste determination, called Genetic Caste Determination (GCD). Colonies within those populations use genotype instead of environment to determine worker and gyne phenotypes. As gynes typically do not contribute to colony maintenance or growth, control over their development should be tightly regulated by the colony. Theoretically, selfish genotypes, those with a heritable propensity for gyne development, should have an immediate fitness advantage and increase in frequency. However, selfish genotypes should be considered evolutionarily unstable, as the gradual loss of worker phenotypes would threaten colony survival. Thus, the presence and

stability of a genetic based system of caste determination in *P. rugosus* and *P. barbatus* is an evolutionary phenomenon; meriting the contribution of several theoretical and empirically based models about the origin, evolution, and maintenance of GCD in that system.

### **Genetic Caste Determination**

GCD in *P. barbatus* and *P. rugosus* is balanced by the continual presence of two lineages within each population: lineage J1 and J2 appear in GCD populations of *P. barbatus*, and lineage H1 and H2 appear in GCD populations *P. rugosus*. Within each lineage, queens are obligatorily polyandrous and must collect sperm from both their own lineage and the alternate lineage in order to start a fully functional colony. For instance, eggs that are fertilized with intra-lineage sperm (e.g. egg: J1, sperm: J1) are fixed developmentally and become gynes. Eggs that are fertilized with inter-lineage sperm (e.g. egg: J1, sperm: J2) are fixed developmentally and become workers. Thus, in order for any GCD queen to have a successful colony, with a strong workforce and new gynes, sperm from both lineages is required. Because queens from each lineage are dependent on the continual presence of males (sperm) from the other lineage, this particular case of GCD is called the Dependent Lineage (DL) system.

### **Evidence for GCD and the DL system**

The DL system was first discovered in 2002 when extreme differences in genetic variation were found between workers and gynes collected from the same colony. Workers tested heterozygous at several nuclear loci, while gynes were respectively homozygous. Further studies revealed that two dependent lineages

existed in each population, and each lineage appeared to be of hybrid origin, sharing alleles with both *P. rugosus* and *P. barbatus*. Eventually, phylogenies of both mitochondrial and nuclear genomes were constructed for the DLs, using ECD samples of *P. rugosus* and *P. barbatus* as an out-group. Surprisingly, the mitochondrial and nuclear phylogenies do not seem to agree on lineage origin (see Figure 1). Lineage J1 and H1 share more nuclear alleles with each other and ECD *P. rugosus*, yet lineage J1 appears morphologically like *P. barbatus*. Lineage J2 and H2 share more nuclear alleles with each other and ECD *P. barbatus*, yet lineage H2 appears morphologically like *P. rugosus*. Lineage J2 and J1 share mitochondrial history with *P. barbatus* and *P. rugosus* respectively, providing evidence for a hybrid origin, yet both phenotypically appear like *P. barbatus*. Curiously, the two *P. rugosus* lineages, H1 and H2, share their mitochondrial origin with J2 and *P. barbatus*.

The incongruence between nuclear origins, mitochondrial origins, and morphologies, has puzzled and confounded most theoretical models presented to explain the origin and evolution of this system. From here I will present a summary of those models, noting the assumptions or explanations that do not match the genetic data depicted in *Figure 2*. I will then provide a new model about the hybrid origin, evolution, and maintenance of the DL system of GCD in *P. rugosus* and *P. barbatus*.

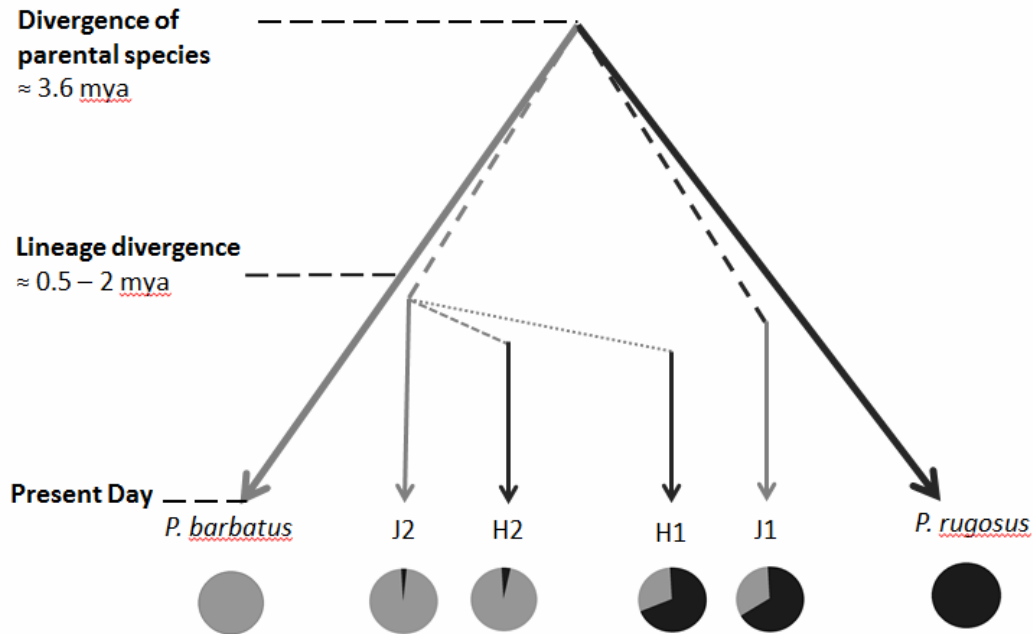

*Figure 2. GCD Phylogeny of Pogonomyrmex.* Here we present visually the most current phylogeny of GCD, depicting the genetic relationship and shared morphologies of the DLs with their parent species *P. rugosus* and *P. barbatus*. Parent species, *P. rugosus* and *P. barbatus* (each of which continue to exhibit ECD), are depicted visually by shades of grey (darker = *P. rugosus*, lighter = *P. barbatus*) The morphologies of each dependent lineage are shown by matching arrows, with darker grey depicting *P. rugosus* morphology and lighter grey depicting *P. barbatus* morphology. Proportions of nuclear alleles shared with each parental species are expressed within the pie-charts shown below the label for each lineage. Dashed lines within the figure denote the mitochondrial origin (i.e. *P. rugosus* or *P. barbatus*) for each dependent lineage.

### *Models of GCD*

Based on the genetic phylogeny shown in *Figure 2*, if any model is to be wholly satisfactory on the origin, evolution, and maintenance of GCD, it must address the following evidences:

- 1) The allelic composition of lineage genomes:
  - a. H1 and J1 share more alleles with *P. rugosus*
  - b. J2 and H2 share more alleles with *P. barbatus*

- 2) The presence of only two alternate lineages within each species
- 3) H1 and H2 shared mitochondrial history with J2
- 4) GCD lineages and ECD populations are sympatrically isolated from themselves and from each other.

### **Previous Models**

Only two models for GCD, out of the many proposed, account for any of the criteria outlined above. The first model, presented by Cahan and Keller (2003), attributes GCD to be the manifestation of incompatibilities between two interacting nuclear loci. Their model is based on the classic Muller-Dobzhansky hybrid model: AABB (*P. rugosus*) x aabb (*P. barbatus*). F<sub>1</sub> inter-specific hybrids would have genotypes AaBb. After several generations of inbreeding within the F<sub>1</sub> line, genotypic combinations AAbb and aaBB arose and, according to their model, those genotypes were fixed for gyne development (forming lineage J1 and J2, respectively). Those alternate genotypes (lineages) then increased in frequency, were of hybrid origin, and workers were made through inter-lineage hybridization. For example, fertilizing a J1 egg (Ab) with sperm from a J2 male (aB) will always result in genotype AaBb. As GCD colonies should have an excess of gynes, AaBb genotypes were suppressed from developing into gynes, and presumably lost that ability over time by genetic drift. The loss of phenotypic plasticity from the hybrid genotype (AaBb) was the facilitator for sympatric isolation of the lineages from each other.

The model above partially addresses evidence (1) and can be interpreted in such a way that it explains evidence (2). For instance, uneven backcrossing

between the parental species and each lineage may have occurred initially, explaining the difference in allelic content for each lineage. The original hybridization between *P. rugosus* and *P. barbatus* may have occurred independently in two different geographies, giving rise to the H-lineages that appear much like *P. rugosus*. However, evidence (3), that of shared mitochondrial origins of the H1, H2, and J2 lineages, and evidence (4), particularly that of sympatric isolation from the *parental species*, remains largely unaddressed by their model.

The second model, by Linksvayer et al (2006), proposes that cytoplasmic-nuclear incompatibilities played a significant role in the establishment of the dependent lineages in both species. In their model, GCD is assumed to have evolved as a consequence of within colony mating, a process that would enforce the association between mitochondrial-type and homozygosity of nuclear alleles. When paired in homozygous form, resulting from within colony mating, nuclear alleles match with co-adapted cytoplasm and bias gyne development. According to their model, workers develop from out-crossing between genetically distant colonies, as that would introduce foreign alleles with a mal-adapted cytoplasm and bias worker development. The necessary pairing of mitochondrial type with nuclear alleles allows for the continual association of homozygosity (of nuclear alleles) with mitochondrial type.

The model proposed by Linksvayer et al (2006) addresses some of the evidences not covered by the Cahan and Keller model, but incorporates additional assumptions to explain the association of mitochondria and nuclear genotype with

each particular lineage. The continual association of mitochondrial type with lineage genotype is necessary to explain evidence (3), but Linksvayer et al. do not explicitly address how the H-lineages came to share a mitochondrial history with J2; especially, if nuclear-cytoplasm interactions enforce the restriction of gene flow between lineages. In order for H1 and H2 to share a mitochondrial history with J2 and be reproductively isolated from each other, genotypic interactions must have a stronger effect on caste in the H-lineages than nuclear-cytoplasm interaction. Thus, the Linksvayer et al. model is really no stronger than Cahan and Keller's, as incompatibility of nuclear alleles would have caused the H-lineages to become genetically isolated from each other.

Additionally, evidence (1) or (2) are not addressed by their model: the reason why only two lineages are found within each GCD population. If within colony mating created GCD, then multiple lineages should be found within each population. Linksvayer's model does, however, address how each lineage would be reproductively isolated from both the other lineage and both the parental populations, satisfying evidence (4).

The models reviewed above perhaps suffer the most from oversimplifying the genetic processes behind caste determination. The evolution of GCD is admittedly a complex phenomenon and any model, in order to satisfy the four genetic evidences depicted in Figure 1, must be descriptively robust and exceptionally clear. Therefore, I wish to present a new model for the evolution of GCD that requires only two admissible assumptions: among colony selection and population wide variation of nutritional thresholds. I believe this model covers



each of the numbered evidences and perhaps can be expanded further to explain the origin and presence of workerless parasite inquilines in the *P. barbatus* phylogeny.

### **A GRN Model for the Evolution of the DLs in *Pogonomyrmex***

Gene Regulatory Networks (GRN) are essentially logic circuits of development. They are typically presented in a visual format and depict the interaction of various regulatory molecules controlling temporal development of an embryo or larvae. A theoretical GRN built to depict ECD should include a nutritional threshold. The nutritional threshold would respond to the quality of the developmental environment. If the environment is poor, that nutritional threshold should produce a signal that blocks wing and ovary development. However, if the environment is rich or above the threshold, either a signal for gyne development or no signal at all should be produced. Considering the evolution of ECD, it would be fitness effective if no signal was produced in high nutrient environments. The evolution of a STOP signal for wing and ovary development sufficiently portrays the genotypic response to selection for caste determination. Downstream of the signal, a region of the GRN responds to the presence or absence of the STOP signal, directly affecting wing and ovary development. That region, if no signal is present should, as a default, allow gyne development to proceed. Evolution would favor this response as STOP signals and worker phenotypes are derived while gyne phenotypes are not.

Here we present a theoretical GRN for ECD as it would have appeared in both parent species: *P. rugosus* and *P. barbatus*.

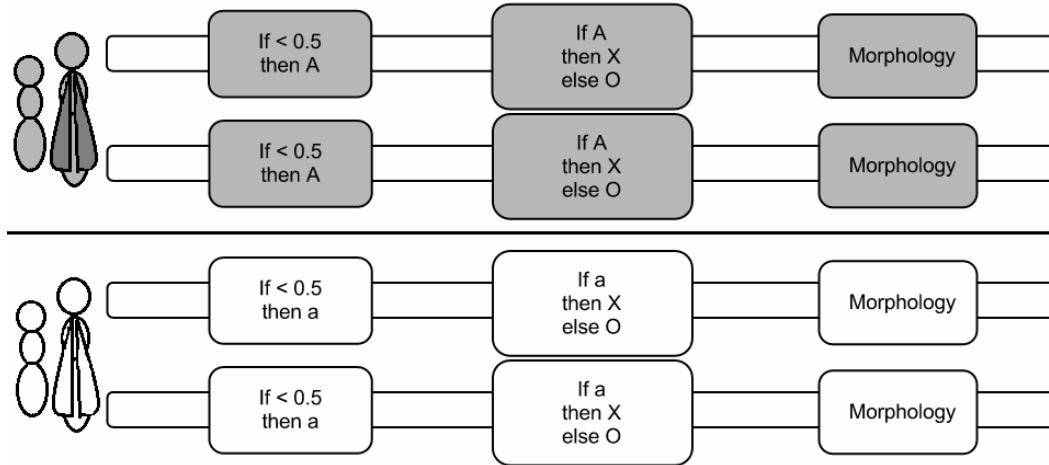

*Figure 3. The GRN for ECD in both Species.* On the left, the possible phenotypes are shown that can develop from these particular GRNs. Temporal development moves from left to right. The nutritional response is given in the left block of code and can be interpreted as follows: If less than 0.5 amount of nutrition is received, then produce signal A (or a). The next block of code responds to this signal: If signal A (or a) is received, then block wing and ovary development (X), otherwise develop as a gyne (O). The gene on the right will eventually be used to associate lineages with morphology (*P. rugosus* or *P. barbatus*). In this model, *P. rugosus* carries the dominant gene for morphology. Note that in *P. barbatus* the suppressor signal for caste is slightly different and is represented by a and not A as it appears in *P. rugosus*.

As the two species hybridize, GRN segments in the F<sub>1</sub> generation would still be responsive to environmental signals as each respective GRN segment would remain intact. The F<sub>1</sub> genotypes can be created in two different scenarios: either a *P. rugosus* queen fertilizes her egg with *P. barbatus* sperm, or visa-versa.

*Figure 4* depicts the F<sub>1</sub> genotype created from either hybridization described above. The F<sub>1</sub> genotypes are bi-potential in terms of potential phenotype (worker or gyne); therefore, based on this model, F<sub>1</sub> gynes should have been relatively common in local mating flights within the geographic overlap between the two species.

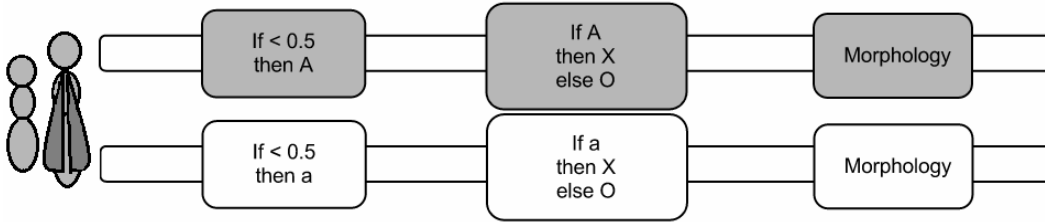

Figure 4. The  $F_1$  Hybrid Genotype and Phenotype. The  $F_1$  genotype resulting from inter-specific hybridization between *P. rugosus* and *P. barbatus* is shown above. The morphology of *P. rugosus* is depicted due to the morphology gene's dominant effect. Because of GRN continuity, these genotypes are bi-potential for both worker and gyne phenotypes.

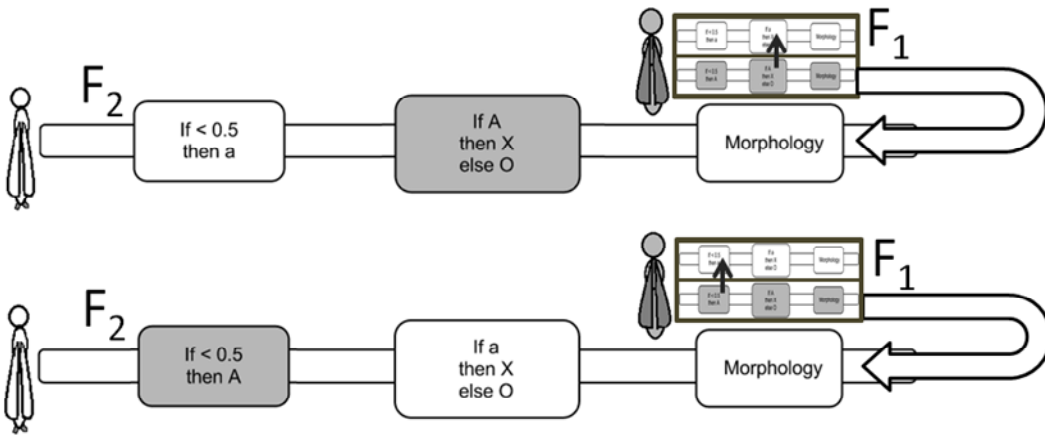
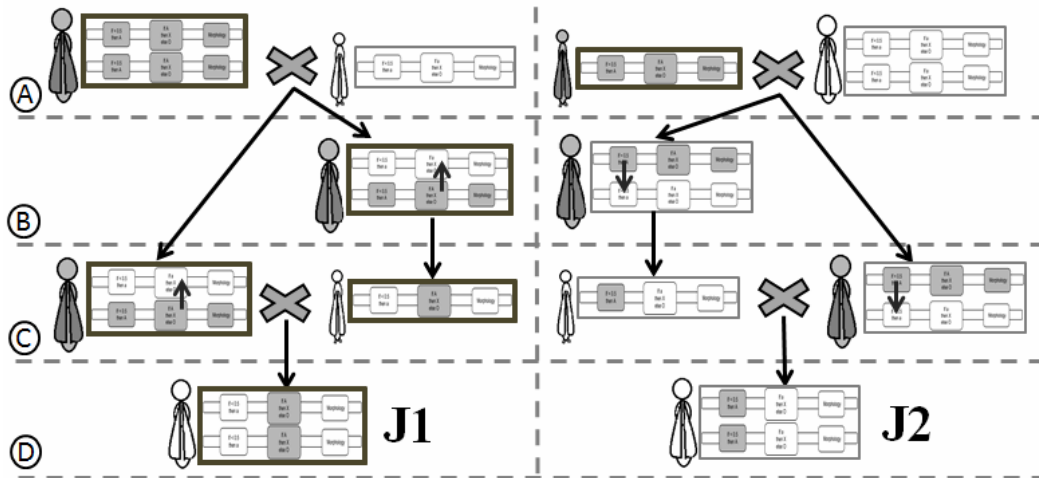

Figure 5. Crossing Over in the  $F_1$  Genotypes. The figure above depicts only two haplotypes (males) of the many possible  $F_2$  hybrid GRN sequence combinations resulting from  $F_1$  meiosis.

$F_1$  gynes, who have successfully mated and started new colonies will generate haploid eggs and fertilize them with the sperm stored in their spermatheca. Due to crossing over and independent assortment, any number of those eggs may contain haploid GRN segments as depicted by the males in Figure 5.  $F_2$  haploid males, developing from unfertilized  $F_1$  eggs, may carry those hybrid segments back to the next mating flight. If one of the  $F_2$  males were to then mate with another  $F_1$  gyne, shown in Figure 4, their sperm could potentially fertilize an egg carrying a homologous GRN (see Figure 6). Genotypic matching between an  $F_2$  sperm and an  $F_1$  egg need only occur *once*, respectively, in order to create two

unique genotypes unresponsive to nutritional environment and fixed for gyne development.

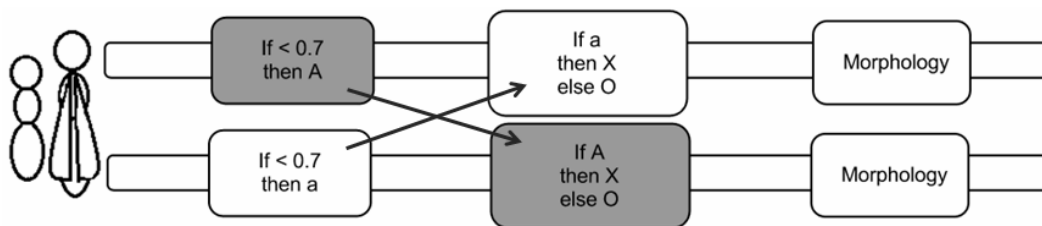

**Figure 6. Establishment of both J-Lineages.** The establishment of hybrid lineages are shown above in sequential order from top to bottom. Generations are separated by (dashed) grey horizontal lines and are marked A through D. Maternally inherited haplotypes are shown on the bottom of each genotypic stack. Mitochondrial lineages are shown by the strength of grey around each genotype (*P. rugosus* = dark grey boxes, *P. barbatus* = light grey boxes). **(A)** The original hybrid mating between a *P. rugosus* queen and a *P. barbatus* male is shown in the left column. The opposite mating pair, a *P. barbatus* queen and a *P. rugosus* male, is shown in the right column. **(B)** Both F<sub>1</sub> progeny share the same genotype, and develop as gynes. Crossing over is depicted by black arrows, respectively, within each F<sub>1</sub> genotype. **(C)** Male genotypes created from crossing over events are shown. Each mate with an F<sub>1</sub> female, possessing a genotype similar to their mother. **(D)** Eggs created from the same respective crossing over event are fertilized with matching sperm. The genotypes resulting from this cross are then fixed for gyne development. Suppressor signals *A* and *a*, respectively, would not longer be recognized by the second block of code in the GRN segment. Consequently, only gyne phenotypes will develop from these genotypes.

So far I have addressed the origin of two GCD lineages of *P. barbatus* morphology. Both lineage haplotypes are hybrid, in terms of nuclear composition, and fixed for gyne development when homozygous. Presumably, these genotypes would increase rapidly in frequency, displacing ECD genotypes. However, as mentioned in the introduction, colonies that are incapable of producing workers

are at a competitive disadvantage and should be removed by selection.

Fortunately, when these haplotypes are paired together in heterozygous form, worker phenotypes can still develop. Alternate receptors will be matched with their respective suppressor signals, provided by the GRN of the other lineage (see *Figure 7*). Heterozygous larvae, although initially bi-potential in terms of phenotype, will likely be suppressed from developing gyne phenotypes (i.e. fed under their respective thresholds) due to an overabundance of gynes developing from homozygous larvae. Among colony selection would favor colonies with more workers; therefore, the nutritional threshold (0.5) should increase within GCD populations, producing signal *A* and *a* more often, respectively, regardless of nutritional environment. Increasing the signal would not affect the fitness of either lineages' haplotype directly, as the signal would not interfere with gyne development; however, it would increase the probability of (heterozygous) worker development and be selectively advantageous at the colony and lineage level.



*Figure 7. The Worker Genotype.* Hybrid lineage genotypes are shown above. Note the nutritional threshold has increased to 0.7, biasing worker development when paired in heterozygous form. Even in higher nutritional environments the first genetic segment produces enzyme *A* and *a*, signaling the alternate segment to produce enzyme "X", effectively blocking wing and ovary development in these individuals.

So far this model explains the origin of GCD for two dependent lineages and their progressive genetic isolation from one another. However, I have not yet addressed the potential for gene-flow with parent species. Essentially, four

possible haplotypes can be distinguished within the general population: *P. rugosus*, *P. barbatus*, J1, and J2. As nutritional thresholds increase within the dependent lineages, respectively, each will produce *P. rugosus* or *P. barbatus* derived suppressor signals in spite of high nutritional environments. As lineage J1's suppressor signal is *P. barbatus* derived, gene-flow between J1 and *P. barbatus* would be less common than gene-flow between J1 and *P. rugosus*. J2's haplotype would interact with both species in a similar, yet opposite fashion (i.e. gene-flow between *P. barbatus* and J2 would be more common than between J2 and *P. rugosus*). Therefore, our model supports evidence (1): J1 shares more alleles with *P. rugosus* and J2 shares more alleles with *P. barbatus*.

Eventually, selection would enforce genetic isolation between each lineage and their complementary parental species. As alternate lineages carry elevated threshold levels than either parental species, among colony selection would favor lineage gynes that have strictly mated with intra-lineage and inter-lineage males. Sperm collected from either parental species would intrinsically carry lower threshold alleles, and hence reduce the overall productivity of GCD colonies as those alleles would not bias worker development.

### **The Establishment of the H-lineages**

So far this model has provided a theoretical mechanism for the establishment of two hybrid dependent lineages and is based primarily on the genomic incompatibility between signals and repressors for wing and ovary development. Gene flow, mitochondrial origins, and nuclear composition of both J-lineages have been addressed and are illustrated by *Figures 2-7*. Sympatric

isolation among lineages and parental species has also been addressed and is based on the assumption that natural selection favored higher nutritional thresholds within GCD populations, forming a selective barrier between both parental species and each lineage. The last evidence that I have not addressed is (3) the mitochondrial origin of both H-lineages.

One of the primary researchers of GCD in *Pogonomyrmex*, Kirk E. Anderson, has suggested that GCD arose first in J2 and spread through hybridization with *P. rugosus* to create the alternate J1 lineage; eventually hybridizing again forming both H-lineages. In contrast to our model, Anderson has proposed that a mutation in the caste loci, one that biases gyne development, arose first in *P. barbatus* and then spread to the other lineages. In fact most of the models proposed for the origin of GCD elicit a "mutation" premise and forgo hybridization as the primary cause of GCD (excluding the Cahan-Keller model). I believe any mutation premise to be a gross misrepresentation of natural selection, as it over generalizes the gradual progress of evolution. If one mutation can overturn millions of years of hard-earned social evolution, then we should expect to find an abundance of eusocial insect species exhibiting similar genetic based systems of caste determination. The fact that the *P. barbatus* complex has many sub-species, including workerless parasitic inquilines, exemplifies the ability of *P. barbatus* to hybridize with closely related species. Anderson's claim is based on evidence (3), the shared mitochondrial history of J2 with both H-lineages. I believe Anderson has arrived at the right conclusion, but from faulty premises. Using the model presented above, I will demonstrate how GCD and J2's

mitochondrial genome could have spread to the H-lineages within only a few generations. Keep in mind that in order for one H-lineage to form and sweep to fixation, the following mechanism only needs to occur once.

### **The Formation of the H1 Lineage**

As mentioned previously, early on in their evolution J1 and J2 had the ability to hybridize with both *P. barbatus* and *P. rugosus*, respectively. The rising nutritional threshold would restrict gene flow between J2 and *P. rugosus*, however, according to genetic evidence (3) those two haplotypes must have hybridized before they became isolated in order to form the H-lineages. The resulting F<sub>1</sub> offspring from that hybridization would carry the J2 mitochondrial genome and remain bi-potential in terms of phenotype. For simplicity and reference purposes only, all of the F<sub>1</sub> (female) offspring resulting from hybridization between J2 gynes and a *P. rugosus* males will be called Jean. Jean carries the J2 mitochondria, is essentially half J2 and half *P. rugosus* in terms of nuclear composition, and can potentially develop either as a worker or gyne. If Jean develops as a gyne, mates with a J1 male and starts a new colony, her J2 mitochondria and almost all her *P. rugosus* alleles may be carried by eggs that are fertilized with J1 sperm (see *Figure 8*). Some of Jean's offspring will develop as gynes and find more J1 males to mate with. As a result, some of those offspring will start colonies with larvae that are fixed for gyne development, as they would possess homozygous hybrid GRNs that are similar to J1. Those individuals, carrying both a J2 mitochondria and J1 nuclear alleles, would start the H1 lineage.



## The Formation of the H2 Lineage

The H2 lineage is more simple to explain, as H2 and J2 share many of the same nuclear alleles, as well as their mitochondria. From the previous section, a J2 gyne hybridized with a *P. rugosus* male and has made bi-potential offspring called Jean. Jean has a maternally inherited J2 mitochondria, is half J2 and half *P. rugosus* in terms of nuclear composition, develops as a gyne, mates with a J2 male, and starts her own colony. With J2 sperm in her spermatheca, Jean could potentially fertilize an egg carrying both her J2 mitochondria and her J2 GRN. Those eggs, homozygous for the J2 GRN, would be fixed for gyne development and begin the J2 lineage. To visualize this process farther, see *Figure 8*.

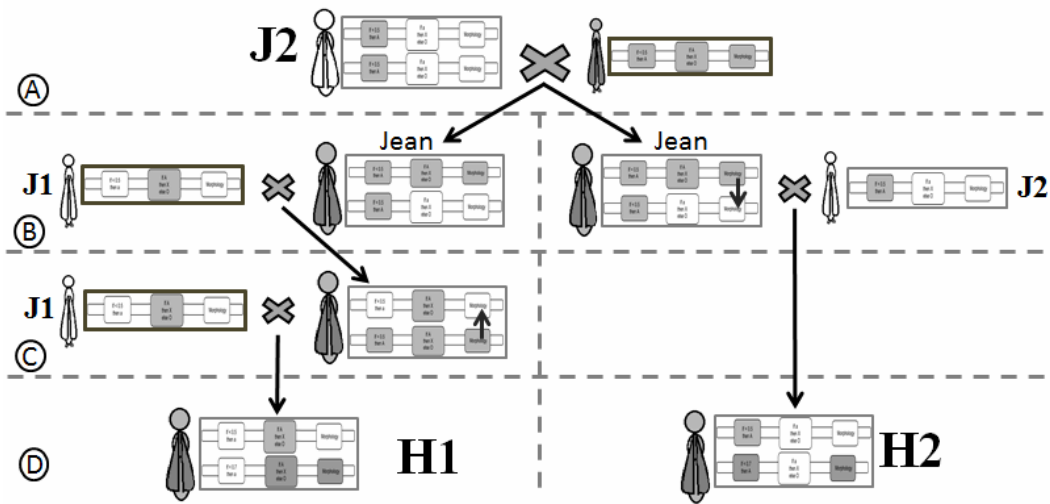

*Figure 8. Establishment of both H-Lineages.* Generations are separated by (dashed) grey horizontal lines and are marked (A) through (D). Lineages are kept separate by the grey vertical (dashed) line. Queen (egg) haplotypes are shown on the bottom of each genotypic stack. Mitochondrial lineages are depicted similar to *Figure 7*. (A) J2 gyne mates with a *P. rugosus* male, creating Jean offspring. (B) Jeans mate with J1 and J2 males, respectively. Crossing over in the J2-mated Jean creates *P. rugosus* morphology on a J2 haplotype, fixing gyne development when it's fertilized with J2-sperm. (C) Crossing over in Jean's offspring (who are half J1 and half *P. rugosus*) creates an egg with *P. rugosus* morphology and fixed for gyne development when fertilized with J1-sperm. (D) Both H-lineages are shown.

## Sympatric Isolation of Hybrid Lineages

There are two contributing explanations for how GCD lineages became sympatrically isolated that will be addressed in this section. The first explanation tackles the theoretical fitness advantage that GCD lineage genotypes have relative to ECD genotypes, within certain parameters. The second proposes that ecological disparities may accumulate between parental species and their respective hybrids; those disparities would then reinforce genetic isolation between them.

### Direct Fitness Advantage of GCD Genotypes

To accurately predict what the ultimate population-level response would be to the presence of fixed genotypes is difficult and confounded by several proximal issues that need to be addressed. In order for either GCD lineage to increase in frequency and out-compete the parental species, the net fitness of GCD genotypes must be higher than the combinatory effect of two constraining variables: that of (1) ECD genotypic fitness and (2) the overall loss of fitness when GCD gynes start colonies with only intra-lineage sperm. For example, an equation for J2's *initial* fitness could be written as:

$$W_{J2} - W_{cost\ J2/J2} > W_{ECD} \quad (1)$$

Constraining factor (1) can be displaced by the immediate advantage of having a cheating genotype; therefore we assume initially  $W_{J2} > W_{ECD}$  and J2 began to increase in frequency. Constraint (2) is less obvious and depends on the generation to generation frequency of J2 within the population.  $W_{cost\ J2/J2}$  is not a fixed value. Rather, it depends on the probability of intra-lineage mating based on the temporal frequency of J2 over time. If J2's frequency increases past a certain

threshold, then  $W_{\text{cost J2/J2}}$  becomes high enough to reduce  $W_{J2}$  below  $W_{ECD}$  and changes the sign of equation (1). We can assume initially  $W_{\text{cost J2/J2}}$  was low and increased relative to the frequency of J2.

Without J1's presence, J2 would have eventually lost its fitness advantage to ECD based on the obvious cost of not being able to produce a work force. Therefore, as Anderson et al. points out (2006), J1 is a necessary fitness complement to J2; one that creates frequency dependence between the two lineages (K. E. Anderson, Holldobler, et al., 2006). Anderson et al. also modeled the dependency function between the two lineages, and found that if both lineages exist in equal frequency, the shared cost of intra-lineage mating and producing unwanted gynes during early colony growth would result in both  $W_{J2}$  and  $W_{J1} < W_{ECD}$ ; that is provided no ecological advantage exists in GCD lineages relative to the ECD parent populations. As GCD is selectively advantageous to ECD in *Pogonomyrmex*, a statement supported by GCD's dominant geographic presence, we are challenged to find that advantage.

### **Ecological Advantage of GCD**

In a recent article on hybrid speciation (Buerkle, Morris, Asmussen, & Rieseberg, 2000), the authors use computer models to simulate inter-specific hybridization, and from those simulations derive the parameter values necessary for sympatric isolation to occur between the hybrid lines and their respective parental species. Contrary to the model I presented, their initial assumption is reduced hybrid fertility ( $F_1$ ). However, once their simulated hybrids restored fertility through generations of successive inbreeding and recombination, their

results offer two insightful predictions that would help facilitate sympatric isolation: (1) considerable exchange of alleles with parental species and (2) strong ecological selection for the hybrid genotype (Buerkle, et al., 2000). As the first assumption was already addressed by the discussion in the previous section, I will focus now on the second (2) and its theoretical implications.

Strong ecological selection on the hybrid genotype, especially in our case, can be broken down into several components and each addressed separately. (A) Each lineage is hybrid in nature, but technically so is the workforce created between them when eggs are fertilized with inter-lineage sperm. Therefore, any conferred selective advantage of being “hybrid” would need further expansion. (B) All hybrids contain alleles from both parental species—alleles that were adapted for unique selective environments—therefore, hybrids may have an ecological advantage within the geographical/environmental overlap between parental species. (C) Inbreeding within hybrid lineages must be balanced by some mechanism such that homozygosity of lineage genotype is still robust enough to handle ecological and genetical perturbation; such as disease, parasites, poorly adaptive alleles, etc.

As mentioned above (A), selection on hybrid genotypes can be addressed on two different levels: The first level is the genotypic fitness of each hybrid lineage (in homozygous form). The second looks at the hybrid workers developing from inter-lineage eggs. I addressed the obvious fitness advantage of GCD genotypes at the beginning of the last section, and as Anderson et al. points out, lineage fitness is based on the population-wide frequency of both lineages (K.

E. Anderson, Holldobler, et al., 2006). Accordingly, any attempt to distinguish the relative fitness advantage of one system over the other (i.e.  $W_{J1}$  or  $W_{J2}$  vs  $W_{ECD}$ ) would be purely contextual. Therefore, in order to determine if ecological competitiveness is possible in the hybrid lines, we should look for any hybrid-advantage GCD *workers* may have over non-hybrid (ECD) workers.

(B) If hybrid workers contain adaptive alleles from each parental species, this could be a case of hybrid vigor; where hybrids experience the phenotypic benefit of having adaptive alleles from two different species. I will explore that hypothesis next section. In the section after, I will empirically investigate (C) how each lineage escapes the inbreeding depression created from limiting reproductive capacity to only intra-lineage genotypes.

### **Apparent Hybrid Vigor in GCD Worker Genotypes**

Heterosis, or hybrid vigor, has been of much interest to both evolutionary biologists and agriculturalists for over a century. Hybrid vigor is the apparent phenotypic superiority of hybrid offspring over both parental species in terms of growth rate, size, reproductive success, and yield (crops). Most often hybrid vigor is associated with agricultural products such as tomato, corn, and rice (Lippman & Zamir, 2007). However, the role of heterosis in hybrid speciation has been tested empirically within several different animal taxa including rats, fruit flies, and fish (Dobzhansky, 1950; Hatfield & Schluter, 1999; Livesay, 1930).

Three hypotheses have been proposed to account for the genetic basis of hybrid vigor (Birchler, Yao, & Chudalayandi, 2006). The first hypothesis states that dominant fitness enhancing alleles (that are always expressed) from each

species would appear in the hybrid, respectively masking any inferior recessive alleles of the alternate species (conditionally expressed); thus, boosting the overall phenotype of the hybrid. The next hypothesis states that an over-dominant effect takes place in the hybrid where paired alleles from both parents, those adapted for different selective environments, are both expressed and interact synergistically in a common environment, giving an added ecological advantage to the phenotype of the hybrid. The final hypothesis is a specific case of the dominance hypothesis and is called pseudo-over dominance. Recessive and dominant alleles are located proximal to one another on the chromosome in one species, and therefore never separate during crossing over. When paired with the other species, recessive alleles are masked and the phenotype of the hybrid appears vigorous.

Although hypotheses for the genetic basis of heterosis have been presented, none can be generally substantiated as not all hybrid crosses result in the same effect. In fact some hybrids are ecologically robust yet remain infertile, such as mules (Laing, 1970). Some hybrids also suffer from genetic incompatibilities and only survive for short periods of time, or their offspring suffer due to assortment and crossing over errors during meiosis; as those kinds of errors typically manifest during development (Techio, Davide, & Pereira, 2006). There are, of course, those cases in which hybrid phenotypes appear to be more vigorous than both parental phenotypes. In most of those cases, however, that vigor is often reduced visibly over time through successive inbreeding within the hybrid lines (Birchler, et al., 2006; Lippman & Zamir, 2007).

Because phenotype is determined by the result of interacting genes, there are two problems that confront any general theory on the genetics of hybrid vigor: (1) too many genes are involved to easily identify candidates and (2) epistasis between interacting genes confounds the ability to detect which of those candidates are actually responsible for the heterotic effect. In a recent review on the subject, Baack and Reieseberg (2007) point out that inter-specific hybridization can result in introgression and exchange of alleles between two species. The evolutionary history, ecology, and life-histories of the two species will determine exactly how many and what types of alleles are permitted to integrate (Baack & Rieseberg, 2007). Thus, in the case of GCD where both parent species share an evolutionary history, similar ecology, and life-history, we expect introgression of both species alleles would occur in the hybrids within a relatively short amount of evolutionary time. Parental alleles that remain in hybrid lineages are likely important for two fitness-related reasons: they either boost the fertility or the ecological traits of the hybrids (Karrenberg, Lexer, & Rieseberg, 2007).

When considering the evolution of heterosis in GCD worker phenotype, it becomes necessary to address how that phenotype is actually inherited. Neither lineage actually contains the worker genotype independently; so natural selection can only affect the worker genotype indirectly by differentially favoring GCD colonies with higher levels of worker productivity, respectively. Therefore, we should be able to compare GCD worker productivity with ECD worker productivity and find evidence for selection favoring the hybrid phenotype. Colony productivity can be measured in several ways: growth (nest size), resource

acquisition (foraging), defense response, worker lifespan, and reproductive fecundity (Bourke, 1995; Brian, 1983; Hölldobler & Wilson, 2009). Empirically, most of these have been investigated in GCD and published by several independent research groups; I will review those findings here.

Colony growth was found to be slightly hindered in GCD colonies relative to ECD colonies due to the upfront resource cost of gynes developing out of season (K. E. Anderson, Holldobler, et al., 2006; T. Schwander, et al., 2006; Tanja Schwander, Keller, et al., 2007). However, Clark et al. suggest, based on experimental observation, that workers tending larvae ameliorate this cost by culling intra-lineage larvae during early stages of colony growth (Clark, et al., 2006). In that same study, the authors also found that worker size in gyne producing colonies of GCD (where the queen had both lineages' sperm) was significantly higher than worker size in non-queen producing colonies of GCD (where queens had only inter-lineage sperm). Their evidence supports the model I proposed earlier: that nutritional thresholds have increased in GCD lineages allowing worker phenotypes to continually develop from inter-lineage larvae, even when exposed to high levels of nutrition; the by product of which would be an increase in worker body mass.

Foraging behaviors were studied in the H1/H2 lineages against ECD *P. rugosus* and no significant differences were found (Glenn E. Julian & Cahan, 2006). In that same study between ECD and GCD colonies, however, worker aggression against disturbances caused by vertebrates (humans) were found to be significantly higher in both GCD lineages. Both GCD and ECD colonies were



found to be more hostile towards each other than with other ant species, indicating that aggressive competition between GCD and ECD colonies may influence their spatial distribution in the field. Non-random spatial distribution within an ecological zone would facilitate genetic isolation between the two populations. However, because elevated aggression was not found to correlate with better foraging in GCD, the authors suggest that higher aggression in GCD workers may be causally linked with higher metabolic rates, which could be selectively advantageous in a different life-history context (Glennis E. Julian & Cahan, 2006). Higher metabolic rates in GCD workers may supersede the upfront cost of intra-lineage gynes developing out of season. Higher metabolic rates would allow fewer workers to accomplish basic colony-level tasks; especially, during early stages of colony growth.

Worker lifespan has not yet been empirically measured in GCD lineages and if tested, may yield some insightful results. Hypothetically, with a slightly longer worker lifespan, GCD colonies could overcome the initial startup cost of intra-lineage egg development by overlapping more worker generations. Over a given interval, more workers could be present in GCD colonies than ECD, pacifying the amount of energy wasted on intra-lineage larvae developing out of season. In 2010 Cahan, Daly, Schwander, and Woods tested colony growth rates between GCD lineages and both ECD parental species (Sara Helms Cahan, Daly, Schwander, & Woods, 2010). Surprisingly, they found all GCD lineages grew significantly faster than ECD *P. rugosus* at colony founding and found no difference with ECD *P. barbatus*. Their methods, however, based growth rate on

the *number of workers present* at given time intervals and at the end of their experiment. Intrinsically, their measure of growth rate includes the number of workers added to the workforce (per unit time) minus the *number of total worker deaths*. If GCD workers have longer life-spans than ECD workers, then their results offer correlative support for this hypothesis.

Although not strictly related to worker heterosis, reproductive maturity in GCD colonies is reached sooner than in ECD colonies and intra-lineage gynes have been produced in lab colonies as early as seven months after colony founding (Clark, et al., 2006). As explained above, increases in fecundity can be attributed to hybrid vigor and can be selectively advantageous. Whether those intra-lineage gynes are functional and their presence attributed to hybrid fecundity, can only be speculated.

In naturally hybridizing species, hybrid vigor could be maintained at relatively high levels within the hybrid lines, provided repeated back-crossing with the parental species occurs in parallel reducing the accumulation of non-functional allele combinations—one of the assumptions in my proposed model, and supported by Buerkle et al (Buerkle, et al., 2000). Given enough time, introgression of parental alleles within each lineage could yield heterotic genotypes as they appear transiently in hybrid workers. Hypothetically, an over-dominant effect could be continually expressed in hybrid workers, as gene-flow is now restricted between the two lineages.

Eventual genetic isolation could be enforced by pre-zygotic mating behaviors, genetic monopoly of reproductive fitness by GCD, and the fact that

continued hybridization with ECD would no longer yield the same level of fitness as hybridizing between lineages (Tanja Schwander, Keller, et al., 2007). Natural selection would eventually favor inter-lineage mating over ECD mating, provided there was an increase in the nutritional-response threshold within both GCD lineages and GCD workers have a heterotic ecological advantage over hybrid GCD/ECD workers. Lower threshold alleles would not be selectively beneficial to GCD colonies. As a matter of fact, their presence would decrease the relative fitness of GCD colonies that outcross with ECD, as they would produce higher ratios of gynes to workers.

### **Overcoming the Inbreeding Depression of Intra-lineage Mating**

Because the model I proposed earlier presumes that each lineage was essentially started by just a few hybrid individuals, whose genotypes spread rapidly to fixation due to an immediate fitness advantage, it becomes necessary to address how genotypic variation would be affected within those lines. If GCD started from a small group of hybrid individuals, then as a result the genetic variation within those lineages would be significantly less than their ECD counterparts. Here I empirically and descriptively measure the recombination frequency of two GCD lineages (H1 and J2) relative to one of the ECD parents (*P. rugosus*). The generative hypothesis described in Chapter 1 is used to support this investigation. Starting from the premise that genetic homogeneity slows the rate of adaptation, I hypothesize that recombination frequency has increased in the GCD lineages relative to the ECD parental species in order to create a larger genotypic economy in which selection can operate more effectively.

## **Introduction**

Genotypic variation is important for ecological stability and can increase the likelihood of survival when populations need to respond genetically to a change in their selective environment (Michod & Levin, 1988). There are two dimensions in which genotypic variation can be considered. The first is temporal and based on the rate of mutation and the recombination frequency between generations. The other is spatial and based on the standing genetic variation already present in the population (Barrett & Schluter, 2008).

Mutation rate is the quantifiable change in a DNA sequence in a population over a specified interval of evolutionary time. Standing genetic variation is the number of alleles, for any given gene, that are currently represented in that same population. Mutations are typically rare, random, and most are selected against, unless they provide some unique fitness advantage to the individual that carries them. Standing variation in a population is generated by mutation, immigration, and emigration.

As mutations are random with respect to genotype, the phenotypic change they elicit is also random. Therefore, populations composed of homogeneous genotypes are at the mercy of their mutation rate to produce adaptations for new selective environments (see Chapter 1: The Evolution of Sex). Populations with higher levels of standing genetic variation are better equipped to handle those changes, provided recombination frequencies around beneficial alleles are variable and can be affected by selection (Otto & Barton, 1997). My hypothesis here is based on the argument made about the evolution of sex in Chapter 1:

genotypic variation helps speed adaptation to a changing environment and should be selected to increase when a population responds to an increase in selective pressure. Without the genetic ability to respond quickly to a change in selective conditions, populations with lower levels of genetic variation will be at a selective disadvantage to those with higher levels of genetic variation.

The claim above presents an issue with the origin and reproductive strategy maintained within GCD populations. GCD lineages are easily identified based on allelic homozygosity at several nuclear gene loci (Sara Helms Cahan, et al., 2002; G. E. Julian, et al., 2002; Volny & Gordon, 2002). That homozygosity is maintained by continual inbreeding within each lineage. By limiting reproductive capacity to only intra-lineage individuals, GCD populations appear to be at a genetic disadvantage to ECD populations in terms of standing genetic variation and hence their ability to adaptively respond to shifts in selective pressure. However, genotypic variation can increase quickly if recombination frequency is variable and heritable (see Chapter 1: generative hypothesis). By increasing recombination frequency and hence the randomness of beneficial allele associations as they appear on a chromosome, natural selection is given a better chance to choose the best combination of alleles for a particular chromosome.

I use the verbal model above to make predictions about the expected recombination rate of GCD populations relative to ECD populations. For instance, GCD populations experience little gene flow, in terms of immigration and emigration, negligible differences in mutation rate with ECD (assumption), and they consistently inbreed; therefore, I predict that each GCD lineage has

genetically responded with an overall increase in their recombination frequency; particularly around gene loci that are under higher levels of selective pressure. I hypothesize that natural selection has acted to increase the genotypic variation in GCD lineages by selecting GCD genotypes with higher meiotic recombination rates. That increase helps to disperse alleles throughout each lineage rapidly (within fewer generations)—provided individuals with beneficial combinations and higher recombination rates have been given enough time to differentially reproduce.

I have empirically tested whether recombination has changed in frequency between two GCD lineages, H2 and J2, and one of the parental species, ECD *P. rugosus*. I used the recently published genome map of ECD *P. barbatus* to find large scaffolds of assembled DNA sequence (more than 3 mega-bases) likely to be shared between GCD and ECD populations. Scaffolds each represent one section of a homologous chromosome hypothetically shared by all populations. By examining recombination frequency at specified intervals along those scaffolds, general inferences can be made about the overall difference in recombination frequency that exists between GCD lineages and their ECD counterparts.

## **Materials and Methods**

**Samples and DNA isolation.** 106 males from three different colonies were used for this experiment. Samples were collected in the field after a heavy monsoon rain during the summer of 2010. Males were placed in labeled vials of 100% ethanol (EtOH) for transportation and storage. One GCD *P. barbatus*

colony was sampled from the southeast corner of the Power and Elliot Road intersection in Mesa, AZ, USA (labeled PE-1). One ECD *P. rugosus* colony was sampled from the field northeast of S. Sossoman Road and East Warner Road, approximately one mile southeast of Power and Elliot (labeled SOS). And one GCD *P. rugosus* colony was received courtesy of Sarah Helms Cahan from Tuscan, AZ, USA (labeled SAR). 16 ECD *P. barbatus* males were also available (from the *P. barbatus* genome mapping project); however, due to the limited power of that sample size, they were not included in this experiment.

Male heads and gasters were removed and discarded before processing. Abdomens were pulverized in 1.6ml tubes with 150  $\mu$ l of 5% Chelex and 1 $\mu$ l of Protease-K. Tubes were incubated in a water bath for approximately 1 hour at 37°C. Tubes were then incubated on a heating block at 95°C for 5 minutes and placed in a centrifuge for 15 minutes at 16,000 rpm. 100 $\mu$ l of supernatant was removed from each tube and placed in a new, labeled 1.6ml vial. Each vial was labeled according to the individual and colony of origin (e.g. M1/PE-1, M1/SAR, M1/SOS, etc.). Tested DNA for all individuals was diluted 1 $\mu$ l/9 $\mu$ l with sterilized H<sub>2</sub>O. All undiluted samples were stored at -20°C.

**Lineage identification.** Each colony's lineage was found using HCO-LCO mitochondrial primers to generate sequence data at the Cox1 locus for three males from each colony. Consensus sequence at the Cox1 locus for all three males from each colony was calculated using alignment software. Those sequences were then compiled with previous study data in MAFFT in order to associate each colony with a group or lineage (e.g. ECD or GCD; J1, J2, H1, or H2). Based on

those results, colony PE-1 associated with J2 lineage (GCD *P. barbatus*), SOS with ECD *P. rugosus*, and SAR with H1 lineage (GCD *P. rugosus*).

**Microsatellite data.** The recently sequenced ECD *P. barbatus* genome map was used to identify adjacent microsatellites (MS) on three of the largest assembled scaffolds. Only two of the scaffolds proved effective for this experiment, Scaffold 1 and Scaffold 3. Forward and Reverse primers were generated for select MS, spaced approximately 0.5kb apart on each scaffold using Primer3 software, and were ordered unlabeled through Integrated DNA Technologies (IDT). Upon arrival, primers were reconstituted with Tris-EDTA buffer (8.0 pH), and PCR master mixes were prepared as per SOP for 30 test males (ten used from each colony). Queen heterozygosity was required at each MS loci in order to establish differential allele inheritance in the male samples. As queen heterozygosity was required, ten males were used in order to reduce the probability of misidentifying the queen as homozygous when she was actually heterozygous at the MS location ( $P = 1.0 \times 10^{-4}$ ). Standard PCR protocol was used for microsatellite amplification (57°C annealing temperature for 45 seconds over 30 cycles). Samples were then loaded onto a 3.25% agarose gel at 74V (60mA) for approximately four hours. Gels were stained in an ethidium bromide (EtBr) bath (20µl/400ml) for 15 minutes and immediately washed and imaged. UV light and Kodac visual imaging camera were used for gel-image capture.

Ten males were used from each colony to test for queen heterozygosity (polymorphism) at proximal microsatellite loci. If heterozygosity was visibly present but allele length differences were too narrow to score, the corresponding



forward primers were ordered labeled through Eurofins MWG Operon (MWG) at either IR700 or IR800. PCR protocol was performed again on the test males using the new labeled primers. That product was then diluted (2 $\mu$ l of product in 96 $\mu$ l of H<sub>2</sub>O). 2 $\mu$ l of diluted product was mixed with 2 $\mu$ l of Licor loading buffer, denatured at 95°C, allowed to anneal, and then ran in a Licor-4300 DNA Analysis System.

If microsatellite regions showed heterozygosity for one colony (based on test male data), DNA from the remaining 96 males from that colony was amplified for that MS marker using the PCR methods described above. Unlabeled PCR products were in ran in 3.25% agarose, stained with EtBr, and images captured using the Kodac UV system. All labeled primers were analyzed with the Licor-4300 system.

**Scoring gels and calculation of recombination frequency.** Both agarose and Licor gels were scored by hand, noting allele length polymorphisms between individual males from one colony. Excel was used to generate a scoring matrix for all tested males. Alleles of longer length were scored with a 1, while shorter alleles were scored with a 0 (see Supplementary Data). All gels were scored twice independently and any discrepancies were removed from the final calculation of recombination frequency.

Recombination frequency was calculated using Kyazma 4.1; a program that arranges MS positions on a chromosome based on their relative recombination frequency across all samples for that colony. Heuristically, the program assembles the MS data on a chromosome based on the least amount of

recombination necessary to assemble MS markers spatially. The program also gives a relative value in cM between each MS marker, as well as relative recombination frequency. A total recombination map was then generated for each colony using the two scaffolds investigated. Recombination frequency was then compared between all colonies.

## **Results**

In order to test whether recombination frequency has increased in GCD populations relative to ECD populations, we used a descriptive mapping technique that focuses on the heritability of sequence structure between the queen and each sampled male. As queens are diploid and males are haploid, each male's genotype is essentially a product of meiosis and ploidy reduction. Our technique measures the frequency of recombination between adjacent polymorphic microsatellites in each one of those males. Microsatellites used for our technique were located within two of the largest scaffolds taken from the genome map assembly of ECD *P. barbatus*. As males are haploid and each represents one outcome of meiosis, we were able to sample the recombination frequency of each queen 106 times for each colony for each MS locus. From that we were able to construct recombination maps for each scaffold for each colony; thus, giving us an accurate estimate of recombination as it occurs throughout a shared genetic region. We used those estimates to compare recombination frequency between colonies PE-1, SAR, and SOS.

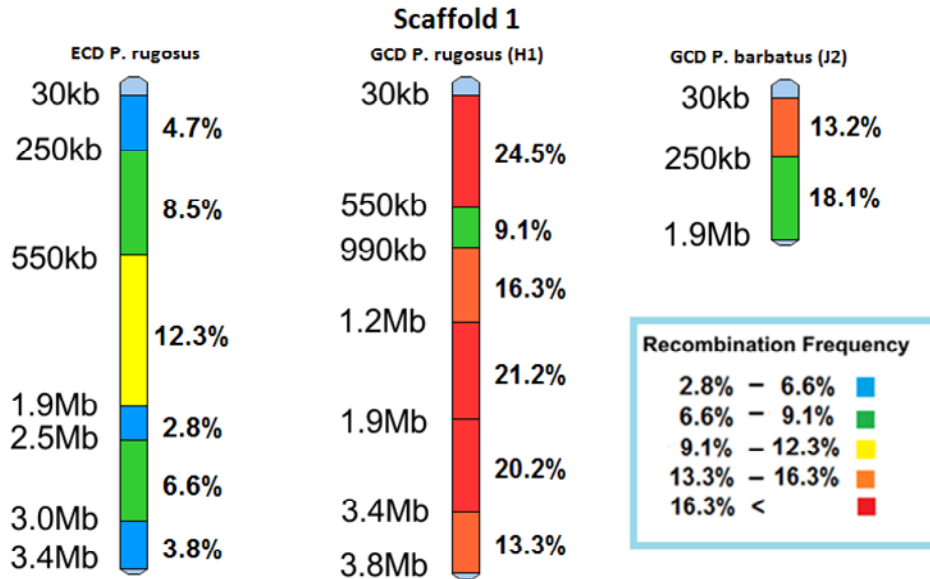

Figure 9. Recombination Frequency in Scaffold 1. This figure represents the percentage of males from each colony that showed recombinant profiles between the sampled MS markers. The left side of each scaffold is labeled according to base-pair position of each MS marker on the scaffold. The percentage shown between two MS markers is the percentage of males that showed recombinant alleles between the two adjacent markers; thus, giving an overall picture of recombinant frequency to compare between colonies. Each colony is labeled accordingly at the top of each scaffold by ECD or GCD with their lineage of origin in parenthesis. Heat mapping colors were added (*ad hoc*) to denote areas of increased recombination.

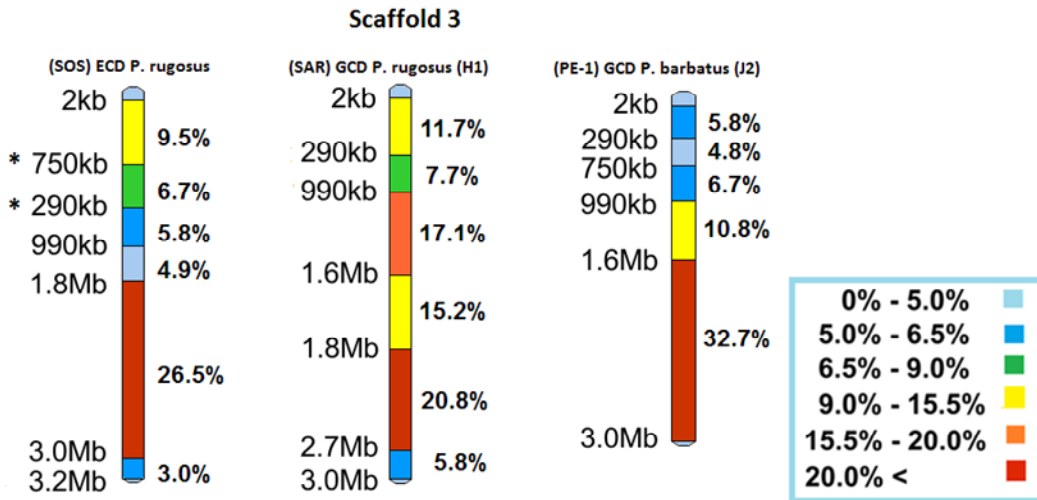

Figure 10. Recombination Frequency in Scaffold 3. This figure represents the recombination frequency measured between adjacent microsatellite markers on the third largest scaffold. Note with SOS, there appears to be an inversion between the markers with an asterisk.

	Average	Error
SOS	8.3%	2.5%
SAR	19.9%	6.1%
PE-1	11.6%	3.5%

*Table 2. Recombination Frequency in Scaffold 1.* This table represents the recombination average per unit measured, and was standardized between all colonies for Scaffold 1. Standardizing was done by taking the average area covered and recombination rate per marker for each colony. Those averages were then used to find the proportional difference of unit area covered between each colony. Those ratios were then multiplied by the average recombination rate measured per unit area for each colony. Finally, the three estimates of total recombination rate per colony were averaged and the standard deviations of those averages are shown in the column to the right.

	Average	Error
SOS	10.0%	0.6%
SAR	13.7%	1.7%
PE-1	11.0%	3.5%

*Table 3. Recombination Frequency in Scaffold 3.* This table represents the recombination average per unit measured, and was standardized between all colonies for Scaffold 3 as described for Table 1.

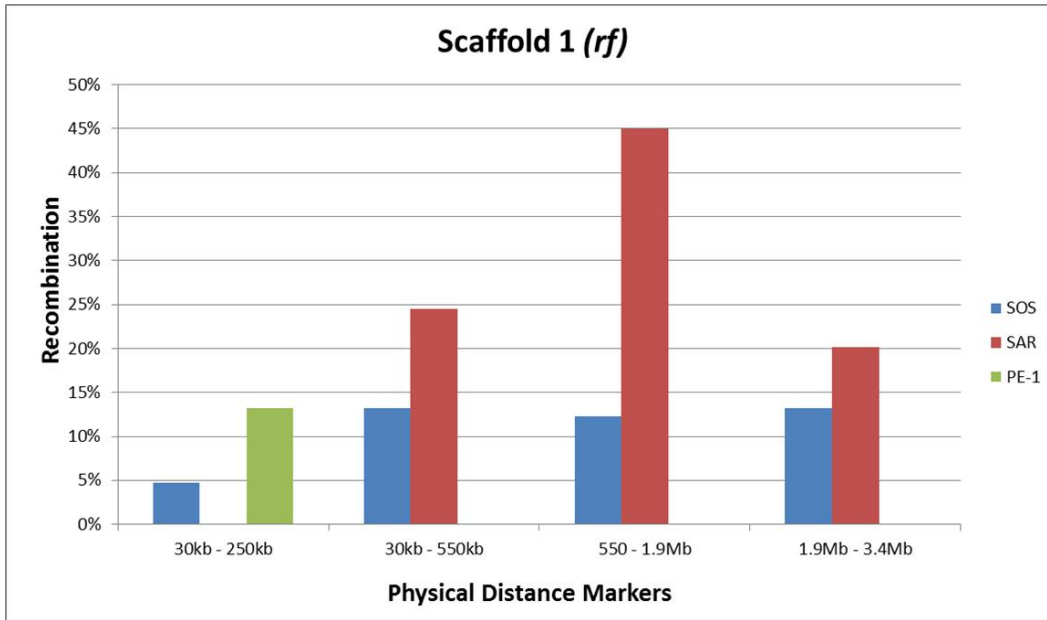

*Figure 11. Recombination Comparison between Shared Markers on Scaffold 1.* The figure above compares the recombination frequency between adjacent microsatellites on Scaffold 1 for each colony. Colonies are denoted by color and the figure legend on the right side of the graph. If colors are not shown, then data does not exist for that particular set of microsatellite markers for that colony.

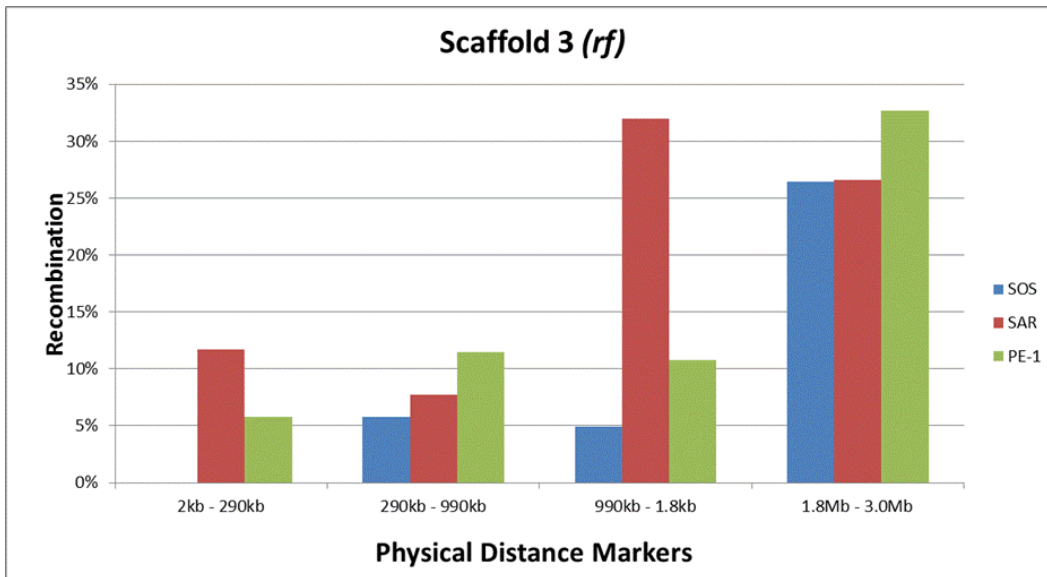

*Figure 12. Recombination Comparison between Shared Markers on Scaffold 1.* The figure above compares the recombination frequency between adjacent microsatellites on Scaffold 1 for each colony. Colonies are denoted by color and the figure legend on the right side of the graph. If colors are not shown, then data does not exist for that particular set of microsatellite markers for that colony.

## Discussion

Because GCD lineages are described and defined by homozygosity at several independent loci, it was an *a priori* assumption that inbreeding within each lineage would reduce population-wide standing genetic variation. Due to the ecologically competitive nature of GCD to ECD, it was apparent that GCD lineages had overcome this inbreeding depression by some currently unknown mechanism. I hypothesized that GCD lineages had responded and overcome the inbreeding depression by an increase in recombination frequency, respective to their ECD counterparts.

Here I tested the hypothesis that recombination frequency has been under selective pressure to increase in the GCD lineages. This investigation focused on the descriptive aspects of recombination frequency between three colony types: ECD *P. rugosus*, GCD *P. rugosus* (H1), and GCD *P. barbatus* (J2). By focusing on regions of shared DNA structure, each one larger than 3Mb, I was able to construct a relatively precise recombination map for each colony within those regions. Two independent regions or scaffolds were investigated, and not all MS primers proved useful or polymorphic for every colony. Gaps between MS markers varied from colony to colony depending on the colony and the markers used. Because only one colony from each lineage was tested, statistical inference cannot be used to make comparisons between samples. Consequently, the recombination estimates calculated here can only provide an interesting medium for discussion.

The first scaffold, although the largest in size, has no known association with GCD markers that have been used to identify GCD lineages. The third scaffold, however, using BLAST software and known primer sequence data from common GCD markers, was found to contain the GCD marker Pb-8. The primer for Pb-8 was identified near the 3.0 Mb region of that scaffold and is commonly used for lineage identification in GCD *P. barbatus* (Volny & Gordon, 2002). Therefore, somewhat serendipitously, the results of this study allow two separate comparisons of recombination frequency to be made: one comparison associated with a known GCD marker and one without.

The first scaffold, without the GCD marker, shows a dramatic increase in recombination frequency between lineage H1 and ECD *P. rugosus* (see *Figure 9*). That increase supports the hypothesis that recombination rates have become more elevated in the GCD lineage. In that same figure, the recombination frequency between ECD *P. rugosus* and J2, however, appears to be quite similar. Fewer markers were functional for J2 on scaffold 1, and hence less data was available; therefore, the ability to adequately compare recombination frequency is also reduced. However, the lack of difference between J2 and ECD *P. rugosus* is not surprising as they share few of the same alleles (Tanja Schwander, Cahan, et al., 2007; Sirviö, et al., 2011). Interestingly, the data shown in *Table 2* suggest that J2 still has a slightly higher recombination frequency than ECD *P. rugosus* in the first scaffold.

The third scaffold, containing GCD marker Pb-8, is not exceptionally different between H1 and ECD *P. rugosus*; however, based on *Table 3*, the

recombination frequency of H1 is slightly higher per unit measured than ECD *P. rugosus*, supporting the posed hypothesis. *Figure 10* also provides support for the hypothesis visually; especially when comparing the two colonies at the beginning and middle of scaffold. As noted in *Figure 10*, ECD *P. rugosus* appears to have an inversion between the second and third MS marker. Because each scaffold and MS marker was derived from the *P. barbatus* genome map, it is possible that ECD *P. rugosus* intrinsically carries this inversion. Although, because recombination frequency is very similar on both sides of the inversion, it is also likely that the computer calculation used in the assembly made a statistical error and simply inverted the two to maintain heuristic integrity. In *Figure 10*, J2 shows an opposite trend as H1 and ECD *P. rugosus*, i.e. less recombination at the beginning and middle of the scaffold and higher towards the end, yet it has an overall average recombination frequency similar to ECD *P. rugosus*; however, that averaged effect may be due to the presence of Pb-8 at the end of that scaffold. Due to consistent homozygosity measured for that marker in previous studies, the area towards the end of the scaffold may be under selective pressure to increase recombination; while the rest of the scaffold is stable and kept together. Contrary to publication, the MS marker for Pb-8 was not homozygous in the colony we sampled. Although the difference in allele lengths was slight, it may be the case that increased recombination frequency around that locus has inadvertently added a few extra repeats to that MS marker throughout the J2 population.

Overall, the trend seems to be in the direction of higher recombination frequencies on average in lineages of GCD relative to ECD *P. rugosus*. In order to



confirm these findings, future research should investigate the variation of recombination frequency within each lineage and population. Without more than one sample, it is impossible to tell if these results are the product of stochastic sampling, or if the rates actually differ. Even with this possibility in mind, the data presented here supports the hypothesis proposed that recombination frequency has increased in the lineages of GCD in order to ameliorate the genetic and ecological cost of inbreeding.

### **Conclusion of this Thesis**

This thesis has moved from general principles of natural selection as outlined by gene-centric views on evolution. I investigated and reviewed the two caveats that appear to conflict with gene-centric suppositions: sexual reproduction and social altruism. I found, based on empirical evidence and theoretical evaluation, that strategies or modes of reproduction will directly reflect the selective pressure for a diversified genome. In heterogeneous environments or highly selective environments, genetic diversity pays off. The offspring of individuals with higher levels of recombination and genotypic variation are more likely to inherit beneficial alleles on a variety of genetic backgrounds. Some of those new genotypes will be selectively advantageous over those with less variable genomes. Because of that, individual genotypes with higher rates of recombination frequency, or those that participate in sexual reproduction, may be selectively advantageous in certain contexts. Thus, by my analysis, sexual reproduction does not directly conflict with gene-centric views on evolution.

The presence of altruistic behavior was proposed by Hamilton to have evolved from an inclusive fitness strategy, coined later by Maynard-Smith as kin selection. I demonstrated that according to Hamilton and Smith, the alleles that predispose individuals for altruistic behaviors must be carried by the immediate relatives of the altruists, or at least by the individuals that are proximally impacted by their altruistic behavior. Based on inclusive fitness, worker genotypes in eusocial insect colonies should be equally related or share similar levels of genetic variation with reproductive genotypes. Presence of caste influencing alleles would threaten the explanatory monopoly held by gene-centric views on evolution. Because of that, I presented and reviewed empirical cases of genetic associations with caste and presented my own study system: that of genetic caste determination (GCD) in populations of *Pogonomyrmex rugosus* and *Pogonomyrmex barbatus*.

### **GCD's Conflict with Gene-Centric Evolution**

The stability and competitiveness of GCD in populations of *Pogonomyrmex* seed harvester ants presents a conflict with gene-centric theories on the evolution and maintenance of eusociality. The conflict exists because inclusive fitness has been reduced over the evolution of GCD. The relatedness of workers to each other (and gynes to each other) is much higher than the relatedness between workers and gynes of a single colony. The relatedness asymmetry between workers and gynes in one colony is roughly the same asymmetry you would expect to find between individuals randomly sampled from a non-social population. Thus, GCD evolved *in opposition to* inclusive fitness,

creating sterile phenotypes *less* related on average to reproductive phenotypes. The inability of either DL to produce workers by intra-lineage mating is further testament to the departure of GCD away from inclusive fitness. However, the continued presence of a vigorous and competitive non-heritable worker phenotype exemplifies natural selection's ability to balance the many different elements of a highly eusocial enterprise.

A stable and competitive system of GCD, violates the predictions made by inclusive fitness theory and gene-centric evolution. Each lineage's genotype is completely incapable of producing more than one phenotype, independently. Even more so, those genotypes have absolutely zero fitness without sperm from the opposite lineage which has been genetically isolated for over one million years. The dependent nature of each lineage on another genetically isolated conspecific lineage defies the logic of gene-centric evolution. It creates a unique and balanced structure of ecological dependency between compatible yet unviable genotypic interactions. When genotypic fitness immediately depends on non-heritable genotypes, gene-centric explanations fall short in their explanatory power. There must be an additional component of natural selection at work that operates beyond the fitness of one genotype.

It is an accepted fact that frequency dependent selection contributes to the maintenance of the DLs in *Pogonomyrmex*. The authors of that conclusion perhaps did not realize they were invoking selective principles beyond inclusive fitness when they made this claim. According to gene-centric evolution, selection acts on heritable variation in fitness. Yet, the fitness component is not directly

inherited by the emergent generation. The fitness component is supplied by the next generation of males from colonies of the alternate, genetically isolated lineage.

As we know, eusocial colonies are affected by selection as if they were one large super-organism (Hölldobler & Wilson, 2009). However, the argument that selection acts on the colony as a single unit is not anti gene-centric in nature. For instance, Richard Dawkins has called the colony an *integrated vehicle*, and thus claims it can be viewed as a single unit of replication (Dawkins, 1989). However, in the case of GCD, I find issue with Dawkin's statement. In his statement, Dawkin's has reduced the colony to one genetic entity, similar in circumstance to a human body. The cells of a human body share a single genotype and, because of their *integration*, their genotypic fitness is represented within the germ line. Therefore, the germ line must genetically represent each cell with the body (or *vehicle*). Synonymously, gynes emerging from a colony must genetically represent each *cell* or worker genotype from their colony. This is never the case in GCD colonies. Gynes emerging from the colony only represent half of the worker genotype.

Because the worker genotype is not, in and of itself, reproductively viable, natural selection, *according to gene-centric evolution*, cannot possibly affect it. Worker genotypes are not heritable, cannot produce viable offspring, and therefore cannot propagate their phenotype through any genetically transferable mechanism. Loss of reproductive capacity from the worker genotype violates the assumption of inclusive fitness I mentioned earlier: worker phenotype (the

altruistic alleles) must be carried *intrinsically* within the genotype of the offspring they are selflessly rearing. In GCD populations the worker phenotype is not carried within either lineage independently, and both lineages are genetically isolated. The worker genotype must therefore be considered a *transient* biological phenomenon. GCD lineage fitness is absolutely dependent on its continued and vigorous presence. The presence of *transient* worker phenotypes in GCD colonies is testament to natural selection's ability to affect multiple layers of biological organization, and not just the heritable fitness from one genotype to another. The alternating generations of lineage fitness exemplify this conclusion.

Evolution by natural selection may proceed by heritable variation in fitness when in non-social or semi-social contexts. However, based on the analysis I put forward, it seems rational to analogize natural selection to an ecological consumer. The market (a genetic based system) will do whatever it needs to in order to be competitive for that consumer's dollar. Competition will increase in complexity, but only through step-by-step stages of ecological and evolutionary growth. Absolutely, personal interest is always a relevant factor in any individual's decision process. But as sociality grows and the relationship between individuals gains complexity, those decisions are not always obvious and relevant to fitness, and most are not even conscious. Just as no one can predict the economic future of our society, we are limited in our predictions of what natural selection can and will create. But if one thing is certain, complexity can only arise from solid foundations. GCD could never have evolved independent of eusocial framework. Dot-com websites could never have been economically prosperous

without the invention of the Internet. In a very humbling and similar analogy, if interpreted correctly, the inventors of the internet never predicted the economic success of the dot-com boom.

## REFERENCES

- Anderson, K. E., Gadau, J., Mott, B. M., Johnson, R. A., Altamirano, A., Strehl, C., et al. (2006). Distribution and evolution of genetic caste determination in Pogonomyrmex seed-harvester ants. *Ecology*, 87(9), 2171-2184.
- Anderson, K. E., Holldobler, B., Fewell, J. H., Mott, B. M., & Gadau, J. (2006). Population-wide lineage frequencies predict genetic load in the seed-harvester ant Pogonomyrmex. *Proc Natl Acad Sci U S A*, 103(36), 13433-13438. doi: 0606055103 [pii]10.1073/pnas.0606055103
- Anderson, K. E., Novak, S. J., & Smith, J. F. (2008). Populations composed entirely of hybrid colonies: bidirectional hybridization and polyandry in harvester ants. *Biological Journal of the Linnean Society*, 95(2), 320-336. doi: 10.1111/j.1095-8312.2008.01051.x
- Baack, E. J., & Rieseberg, L. H. (2007). A genomic view of introgression and hybrid speciation. *Current Opinion in Genetics & Development*, 17(6), 513-518. doi: 10.1016/j.gde.2007.09.001
- Baker, B. S., Carpenter, A. T. C., Esposito, M. S., Esposito, R. E., & Sandler, L. (1976). The Genetic Control of Meiosis. *Annual Review of Genetics*, 10(1), 53-134. doi: doi:10.1146/annurev.ge.10.120176.000413
- Barrett, R. D. H., & Schluter, D. (2008). Adaptation from standing genetic variation. *Trends in Ecology & Evolution*, 23(1), 38-44. doi: 10.1016/j.tree.2007.09.008
- Beadle, G. W., & Tatum, E. L. (1941). Genetic Control of Biochemical Reactions in Neurospora. *Proc Natl Acad Sci U S A*, 27(11), 499-506.
- Becks, L., & Agrawal, A. F. (2010). Higher rates of sex evolve in spatially heterogeneous environments. [10.1038/nature09449]. *Nature*, 468(7320), 89-92. doi: <http://www.nature.com/nature/journal/v468/n7320/abs/nature09449.html#supplementary-information>
- Bell, G. (1982). *The Masterpeice of Nature: The Evolution and Genetics of Sexuality*. Berkeley, California: University of California Press.
- Birchler, J. A., Yao, H., & Chudalayandi, S. (2006). Unraveling the genetic basis of hybrid vigor. *Proceedings of the National Academy of Sciences*, 103(35), 12957-12958. doi: 10.1073/pnas.0605627103

- Bourke, A. F., Franks, Nigel R. (1995). *Social Evolution in Ants*. Princeton, New Jersey: Princeton University Press.
- Brian, M. V. (1983). *Social Insects: Ecology and Behavioral Biology*. New York, New York: Chapman and Hall Ltd.
- Buerkle, C. A., Morris, R. J., Asmussen, M. A., & Rieseberg, L. H. (2000). The likelihood of homoploid hybrid speciation. *Heredity*, *84*(4), 441-451.
- Cahan, S. H., Daly, A. B., Schwander, T., & Woods, H. A. (2010). Genetic caste determination does not impose growth rate costs in Pogonomyrmex harvester ants. [Article]. *Functional Ecology*, *24*(2), 301-309. doi: 10.1111/j.1365-2435.2009.01629.x
- Cahan, S. H., Julian, G. E., Rissing, S. W., Schwander, T., Parker, J. D., & Keller, L. (2004). Loss of Phenotypic Plasticity Generates Genotype-Caste Association in Harvester Ants. *Current Biology*, *14*(24), 2277-2282. doi: 10.1016/j.cub.2004.12.027
- Cahan, S. H., Julian, G. E., Schwander, T., & Keller, L. (2006). Reproductive Isolation between Pogonomyrmex rugosus and Two Lineages with Genetic Caste Determination. *Ecology*, *87*(9), 2160-2170.
- Cahan, S. H., & Keller, L. (2003). Complex hybrid origin of genetic caste determination in harvester ants. *Nature*, *424*(6946), 306-309. doi: 10.1038/nature01744nature01744 [pii]
- Cahan, S. H., Parker, J. D., Rissing, S. W., Johnson, R. A., Polony, T. S., Weiser, M. D., et al. (2002). Extreme genetic differences between queens and workers in hybridizing Pogonomyrmex harvester ants. *Proceedings of the Royal Society of London. Series B: Biological Sciences*, *269*(1503), 1871-1877. doi: 10.1098/rspb.2002.2061
- Chéron, B., Monnin, T., Fédérici, P., & Doums, C. (2011). Variation in patriline reproductive success during queen production in orphaned colonies of the thelytokous ant *Cataglyphis cursor*. *Molecular Ecology*, *20*(9), 2011-2022. doi: 10.1111/j.1365-294X.2011.05075.x
- Clark, R. M., Anderson, K. E., Gadau, J., & Fewell, J. H. (2006). Behavioral regulation of genetic caste determination in a Pogonomyrmex population with dependent lineages. *Ecology*, *87*(9), 2201-2206.
- Clémencet, J., Rome, Q., Fédérici, P., & Doums, C. (2008). Aggressions and size-related fecundity of queenless workers in the ant *Cataglyphis cursor*. *Naturwissenschaften*, *95*(2), 133-139. doi: 10.1007/s00114-007-0304-5



- Crow, J. F., & Kimura, M. (1965). Evolution in Sexual and Asexual Populations. *The American Naturalist*, 99(909), 439-450.
- Darwin, C. R. (1859). *On the Origin of Species by Means of Natural Selection, or the Preservation of Favoured Races in the Struggle for Life* (1st ed.). London: John Murray.
- Dawkins, R. (1978). Replicator Selection and the Extended Phenotype. *Zeitschrift für Tierpsychologie*, 47(1), 61-76. doi: 10.1111/j.1439-0310.1978.tb01823.x
- Dawkins, R. (1989). *The selfish gene*. Oxford; New York: Oxford University Press.
- Dobzhansky, T. (1950). Genetics of Natural Populations. XIX. Origin of Heterosis through natural selection in populations of *Drosophila pseudoobscura*. *Genetics*, 35(3), 288-302.
- Engbrecht, J., Hirsch, J., & Roeder, G. S. (1990). Meiotic gene conversion and crossing over: Their relationship to each other and to chromosome synapsis and segregation. *Cell*, 62(5), 927-937.
- Fisher, R. A. (1918). The Correlation Between Relatives on the Supposition of Mendelian Inheritance. *Philosophical Transactions of the Royal Society of Edinburgh*, 52, 399-433.
- Fisher, R. A. (1930). *The Genetical Theory of Natural Selection*. Oxford: Oxford University Press.
- Foucaud, J., Estoup, A., Loiseau, A., Rey, O., & Orivel, J. (2010). Thelytokous parthenogenesis, male clonality and genetic caste determination in the little fire ant: new evidence and insights from the lab. *Heredity*, 105(2), 205-212. doi: <http://www.nature.com/hdy/journal/v105/n2/supinfo/hdy2009169s1.html>
- Ghiselin, M. T. (1969). The Evolution of Hermaphroditism Among Animals. *The Quarterly Review of Biology*, 44(2), 189-208.
- Gordon, D. M., & Kulig, A. W. (1996). Founding, Foraging, and Fighting: Colony Size and the Spatial Distribution of Harvester Ant Nests. *Ecology*, 77(8), 2393-2409.
- Hamilton, W. D. (1963). The Evolution of Altruistic Behavior. *The American Naturalist*, 97(896), 354-356.

- Hamilton, W. D. (1964a). The genetical evolution of social behaviour. I. *Journal of Theoretical Biology*, 7(1), 1-16. doi: 10.1016/0022-5193(64)90038-4
- Hamilton, W. D. (1964b). The genetical evolution of social behaviour. II. *Journal of Theoretical Biology*, 7(1), 17-52. doi: 10.1016/0022-5193(64)90039-6
- Hamilton, W. D. (1970). Selfish and Spiteful Behaviour in an Evolutionary Model. [10.1038/2281218a0]. *Nature*, 228(5277), 1218-1220.
- Hatfield, T., & Schluter, D. (1999). Ecological Speciation in Sticklebacks: Environment-Dependent Hybrid Fitness. *Evolution*, 53(3), 866-873.
- Hölldobler, B., & Wilson, E. O. (2009). *The Superorganism: The Beauty, Elegance, and Strangeness of Insect Societies*. New York, New York: W. W. Norton & Company, Inc.
- Hull, D. L. (1980). Individuality and Selection. *Annual Review of Ecology and Systematics*, 11(1), 311-332. doi: doi:10.1146/annurev.es.11.110180.001523
- Julian, G. E., & Cahan, S. H. (2006). Behavioral Differences Between Pogonomyrmex rugosus and Dependent Lineage (H1/H2) Harvester Ants. *Ecology*, 87(9), 2207-2214. doi: 10.1890/0012-9658(2006)87[2207:bdbpra]2.0.co;2
- Julian, G. E., Fewell, J. H., Gadau, J., Johnson, R. A., & Larrabee, D. (2002). Genetic determination of the queen caste in an ant hybrid zone. *Proc Natl Acad Sci U S A*, 99(12), 8157-8160. doi: 10.1073/pnas.112222099112222099 [pii]
- Karrenberg, S., Lexer, C., & Rieseberg, Loren H. (2007). Reconstructing the History of Selection during Homoploid Hybrid Speciation. *The American Naturalist*, 169(6), 725-737.
- Keller, & Ross. (1999). Major gene effects on phenotype and fitness: the relative roles of Pgm-3 and Gp-9 in introduced populations of the fire ant *Solenopsis invicta*. *Journal of Evolutionary Biology*, 12(4), 672-680. doi: 10.1046/j.1420-9101.1999.00064.x
- Kerr, W. E. (1950a). Genetic determination of castes in the genus *Melipona*. *Genetics*, 35(2), 143-152.
- Kerr, W. E. (1950b). Evolution of the Mechanism of Caste Determination in the Genus *Melipona*. *Evolution*, 4(1), 7-13.

- Kobayashi, K., Hasegawa, E., & Ohkawara, K. (2008). Clonal reproduction by males of the ant *Vollenhovia emeryi* (Wheeler). *Entomological Science*, *11*(2), 167-172. doi: 10.1111/j.1479-8298.2008.00272.x
- Kobayashi, K., Hasegawa, E., & Ohkawara, K. (2011). No gene flow between wing forms and clonal reproduction by males in the long-winged form of the ant <i>Vollenhovia emeryi</i>. *Insectes Sociaux*, *58*(2), 163-168. doi: 10.1007/s00040-010-0131-0
- Koehler, K. E., Hawley, R. S., Sherman, S., & Hassold, T. (1996). Recombination and nondisjunction in humans and flies. *Human molecular genetics*, *5 Spec No*, 1495-1504.
- Korol, A. B., & Iliadi, K. G. (1994). Increased recombination frequencies resulting from directional selection for geotaxis in *Drosophila*. *Heredity*, *72*(1), 64-68.
- Laing, J. A. (Ed.). (1970). *Fertility and infertility in the domestic animals; aetiology, diagnosis, and treatment* (2d ed.). Baltimore, MD: Williams and Wilkins
- Lewin, B. (2000). *Genes VII*. New York: Oxford University Press Inc.
- Lin, N., & Michener, C. D. (1972). Evolution of Sociality in Insects. *The Quarterly Review of Biology*, *47*(2), 131-159.
- Linksvayer, T. A., Wade, M. J., & Gordon, D. M. (2006). Genetic Caste Determination in Harvester Ants: Possible Origin and Maintenance by Cyto-Nuclear Epistasis. *Ecology*, *87*(9), 2185-2193. doi: 10.1890/0012-9658(2006)87[2185:gcdiha]2.0.co;2
- Lippman, Z. B., & Zamir, D. (2007). Heterosis: revisiting the magic. *Trends in Genetics*, *23*(2), 60-66. doi: 10.1016/j.tig.2006.12.006
- Livesay, E. A. (1930). An Experimental Study of Hybrid Vigor or Heterosis in Rats. *Genetics*, *15*(1), 17-54.
- Merriam, J. R., & Frost, J. N. (1964). Exchange and nondisjunction of the X chromosomes in female *Drosophila melanogaster*. *Genetics*, *49*(1), 109-122.
- Michod, R. E., & Levin, B. R. (Eds.). (1988). *The Evolution of Sex: An Examination of Current Ideas*. Sunderland, Massachusetts: Sinauer Associates Inc.

- Muller, H. J. (1932). Some Genetic Aspects of Sex. *The American Naturalist*, 66(703), 118-138.
- Otto, S. P., & Barton, N. H. (1997). The evolution of recombination: removing the limits to natural selection. *Genetics*, 147(2), 879-906.
- Queller, D. C., & Strassmann, J. E. (1998). Kin Selection and Social Insects. *BioScience*, 48(3), 165-175.
- Ross, K. G., & Keller, L. (1995). Joint Influence of Gene Flow and Selection on a Reproductively Important Genetic Polymorphism in the Fire Ant *Solenopsis invicta*. *The American Naturalist*, 146(3), 325-348.
- Schwander, T., Cahan, S. H., & Keller, L. (2006). Genetic caste determination in *Pogonomyrmex* harvester ants imposes costs during colony founding. *Journal of Evolutionary Biology*, 19(2), 402-409.
- Schwander, T., Cahan, S. H., & Keller, L. (2007). Characterization and distribution of *Pogonomyrmex* harvester ant lineages with genetic caste determination. [Article]. *Molecular Ecology*, 16(2), 367-387. doi: 10.1111/j.1365-294X.2006.03124.x
- Schwander, T., Keller, L., & Cahan, S. H. (2007). Two alternate mechanisms contribute to the persistence of interdependent lineages in *Pogonomyrmex* harvester ants. [Article]. *Molecular Ecology*, 16(17), 3533-3543. doi: 10.1111/j.1365-294X.2007.03407.x
- Schwander, T., Suni, S. S., Cahan, S. H., & Keller, L. (2008). Mechanisms of Reproductive Isolation between an Ant Species of Hybrid Origin and One of Its Parents. *Evolution*, 62(7), 1635-1643.
- Sirviö, A., Pamilo, P., Johnson, R. A., Page, J. R. E., & Gadau, J. (2011). Origin and Evolution of the Dependent lineages in the Genetic Caste Determination System of *Pogonomyrmex* Ants. *Evolution*, 65(3), 869-884. doi: 10.1111/j.1558-5646.2010.01170.x
- Sirvio, A., Pamilo, P., Johnson, R. A., Page, R. E., Jr., & Gadau, J. (2011). Origin and evolution of the dependent lineages in the genetic caste determination system of *Pogonomyrmex* ants. *Evolution*, 65(3), 869-884. doi: 10.1111/j.1558-5646.2010.01170.x
- Smith, J. M. (1964). Group Selection and Kin Selection. [10.1038/2011145a0]. *Nature*, 201(4924), 1145-1147.

- Smith, J. M. (1968). Evolution in Sexual and Asexual Populations. *The American Naturalist*, 102(927), 469-473.
- Smith, J. M., & Price, G. R. (1973). The Logic of Animal Conflict. [10.1038/246015a0]. *Nature*, 246(5427), 15-18.
- Taber, S. W. (1998). *The World of the Harvester Ants* (1st ed. Vol. 23): Texas A&M University Press.
- Techio, V. H., Davide, L. C., & Pereira, A. V. (2006). Meiosis in elephant grass (*Pennisetum purpureum*), pearl millet (*Pennisetum glaucum*) (Poaceae, Poales) and their interspecific hybrids. *Genetics and Molecular Biology*, 29, 353-362.
- Volny, V. P., & Gordon, D. M. (2002). Genetic basis for queen-worker dimorphism in a social insect. *Proc Natl Acad Sci U S A*, 99(9), 6108-6111. doi: 10.1073/pnas.092066699092066699 [pii]
- Watt, V. M., Ingels, C. J., Urdea, M. S., & Rutter, W. J. (1985). Homology requirements for recombination in *Escherichia coli*. *Proc Natl Acad Sci U S A*, 82(12), 4768-4772.
- West, S. A., Gardner, A., & Griffin, A. S. (2006). Altruism. *Current Biology*, 16(13), R482-R483. doi: 10.1016/j.cub.2006.06.014
- Wheeler, D. E. (1986). Developmental and Physiological Determinants of Caste in Social Hymenoptera: Evolutionary Implications. *The American Naturalist*, 128(1), 13-34.
- Wheeler, D. E. (1991). The Developmental Basis of Worker Caste Polymorphism in Ants. *The American Naturalist*, 138(5), 1218-1238.
- Williams, G. C. (1966). *Adaptation and Natural Selection*. Princeton, N.J.: Princeton University Press.
- Wynne-Edwards, V. C. (1962). *Animal Dispersion in Relation to Social Behaviour*. Edinburgh and London: Oliver and Boyd.