

Quantifying the Properties of Elastic, Liquid Metal Based Thermal Interface Materials

by

Nicholas Kemme

A Thesis Presented in Partial Fulfillment
of the Requirements for the Degree
Master of Science

Approved March 2017 by the
Graduate Supervisory Committee:

Konrad Rykaczewski, Co-Chair
Robert Wang, Co-Chair
Liping Wang

ARIZONA STATE UNIVERSITY

May 2017

ABSTRACT

Advancements in thermal interface materials (TIMs) allows for the creation of new and more powerful electronics as they increase the heat transfer from the component to the heat sink. Current industrial options provide decent heat transfer, but the creation of TIMs with higher thermal conductivities is needed. In addition, if these TIMs are elastic in nature, their effectiveness can greatly increase as they can deal with changing interfaces without degradation of their properties. The research performed delves into this idea, creating elastic TIMs using liquid metal (LM), in this case galinstan, along with other matrix particles embedded in Polydimethylsiloxane (PDMS) to create an easy to use, relatively inexpensive, thermally conductive, but electrically insulative, pad with increased thermal conductivity from industrial solutions.

The pads were created using varying amounts of LM and matrix materials ranging from copper microspheres to diamond powder mixed into PDMS using a high-speed mixer. The material was then cast into molds and cured to create the pads. Once the pads were created, the difficulty came in quantifying their thermal properties. A stepped bar apparatus (SBA) following ASTM D5470 was created to measure the thermal resistance of the pads but it was determined that thermal conductivity was a more usable metric of the pads' performance. This meant that the pad's in-situ thickness was needed during testing, prompting the installation of a linear encoder to measure the thickness. The design and analysis of the necessary modification and proposed future design is further detailed in the following paper.

ACKNOWLEDGEMENTS

I would like to thank Dr. Konrad Rykaczewski and Dr. Robert Wang for all the support and guidance they have given me as I worked toward the completion of my degree. They have been more than helpful and really have inspired me to achieve the best that I can.

Nicholas Kemme

TABLE OF CONTENTS

| | Page |
|---|------|
| LIST OF FIGURES..... | iv |
| CHAPTER | |
| 1. INTRODUCTION..... | 1 |
| 1.1 What are Thermal Interface Materials and Why are They Important?..... | 1 |
| 1.2 Current Research into TIM Improvement | 3 |
| 2. QUANTIFICATION OF TIM PROPERTIES VIA A STEPPED BAR APPARATUS | 5 |
| 2.1 Quantification of TIM Properties | 5 |
| 2.2 Design and Modification of a SBA Apparatus..... | 7 |
| 2.3 Thermal Considerations..... | 20 |
| 3. SBA USER’S MANUAL..... | 23 |
| 3.1 Guide to Using the SBA | 23 |
| 3.2 SBA Disassembly and Reassembly Procedures | 24 |
| 4. CONCLUSION..... | 26 |
| 4.1 Conclusion..... | 26 |
| REFERENCES..... | 27 |

LIST OF FIGURES

| Figure | Page |
|---|------|
| <p>1.1 Schematic Illustrating The Action Of Thermal Interface Material, Which Fills The Gaps Between Two Contacting Surfaces. The Heat Removal Improves With Higher Thermal Conductivity, Smaller Bond Line Thickness And Contact Resistance Of The Material. ¹.....</p> | 2 |
| <p>2.1 (a) ASTM D5470 Thermal Measurement Setup.³ (b)¹ Potential Misalignment Shown In An Exaggerated Fashion If The Bars Were The Same Cross Section. This Would Lead To A Reduction In Area For The Heat Flux, Skewing Results. (c) Schematics Of The New Reference Bars (In mm) With [A] Being The Top (Hot) And [B] Being The Bottom (Cold). The Bars Are Square In Profile And The Thermocouple Holes Go To The Center Of The Bars To Ensure The Readings Are Accurate.....</p> | 9 |
| <p>2.2 Depiction Of Our Original SBA Setup. Note: The System Rests On Rubber Feet To Insulate It From The Table Top. (a) ACME Screw Drive With Hand Wheel. (b) Teflon Sleeve Bearings, Allowing The Middle Plate To Slide Smoothly On The Support Shafts. (c) 500N Load Cell. (d) Floating Plate To Allow For Force Reading While Holding The Upper Reference Bar Assembly In Place. (e) High Temperature Reservoir With Hole For Heating Element. (f) Upper Reference Bar. (g) Lower Reference Bar. (h) Low Temperature Reservoir With Hole For Circulating Cooling Fluid. (i) Enlarged View Of The Reference Bar Setup With Visible Thermocouple Holes.....</p> | 10 |

| Figure | Page |
|--|------|
| 2.3 Left: Side View Of The Linear Encoder Setup. The Support Bars (a) Connecting The High Temperature Reservoir To The Linear Encoder (c) Are In Red While The Read Head Is In Yellow (b). The Linear Bearings Are Sleeve Bearings And Ride On Polished Steel Rails To Help Counteract Cantilever Forces And To Protect The Carbon Fiber Reference Rod (Hidden Behind Support Shaft) From Lateral Or Torsional Forces Due To Thermal Expansion And Machining Error. Right: Alternate View (d) Is The Carbon Fiber Reference Rod..... | 12 |
| 2.4 (a) Linear Ball Bearings Were Installed To Replace The Teflon Sleeve Bearings. (b) Counterweight Added To Bring The Center Of Gravity Of The System Back To The Center Of The Reference Bar To Reduce Tilting. (c) Spacers Are Added And The Load Cell Is Removed To Anchor The Whole System. (d) Ball Bearings Replace Sleeve Bearings Here As Well. (e) Brackets Are Added To Mount The Linear Encoder To The Middle Plate For Higher Accuracy..... | 14 |
| 2.5 Isometric Cross Section Of Finalized Modifications, Showing Counterweight Profile As Well As Configured Without The Load Cell. | 14 |
| 2.6 Basic Proposed SBA 2.0 Design. (a) Reference Bars Remain The Same, Upper One Is Fixed To The Top Plate. (b) Mounting Plate With Thermal Insulation Boundary Between Heat Reservoir. Note The Side Bracket To Mount The Linear Encoder Head. (c) Newport MVN120 Vertical Stage With BM25.40 Micrometer. (d) Array Of Low Profile, Direct Mount Load Cells. (e) Linear Encoder Head, With Reference Rod Mounted To The Top Plate. The Black Box At The Back Represents An Area For Control Systems That Are Currently House Outside Of The SBA Setup. | 18 |

| Figure | Page |
|---|------|
| 2.7 Copper Pyramid TIM Tester Photograph And Schematic..... | 19 |
| 2.8 Schematic Of Murray et. al.'s ⁸ SBA Setup. Note That The Force On The Sample Is Provided From Physically Stacking More Weight On Top Of The Sample, With The Max Force Being About 177N..... | 20 |
| 2.9 Thermal Analysis Showing The Maximum Thermal Shift Is Around 70μm. This Analysis Assumes That The Setup Was Zeroed At Room Temperature Then Turned On And Left To Reach Steady State. In Addition, This Analysis Uses The Update Stainless Steel Reference Bars And Has Only 1N Of Force Applied To The Sample, Showing The Worst-Case Deformation..... | 22 |

CHAPTER 1

Introduction to Thermal Interface Materials

1.1 What are Thermal Interface Materials and Why are They Important?

Thermal interface materials (TIMs) are important to our everyday life as they permit the high-performance computing to which we have all become accustomed. As electronics become smaller and more powerful, one must consider the localized heat buildup as a critical design component; however, this becomes increasingly difficult as the trend towards smaller and lighter continues. Heat must be removed from these components and transferred to cooling devices such as heat sinks and heat pipes but the thermal contact between two parts, even precision machined parts is poor at best.^{9,10} TIMs become the critical component that solves this problem as they are often either a paste or elastic substance that fills the gaps between the parts and improves the thermal contact (Fig. 1) They are often made as a paste or thin pad that is applied between the two components and is then compressed to create the connection. Generally, TIMs are electrically insulating as this is important to maintain proper function of the electrical components, namely CPU chips that may have hundreds of thousands of connections on them.

Currently, the issue with off-the-shelf TIMs is that while they do enhance the heat transfer capabilities of a system, they are still relatively low in comparison to metals of the two parts. Currently, the highest rated industrial TIM available is the T-Global TXG Thermal Pad with a thermal conductivity (K) of 12 W/mK and is advertised as being used only for industrial computers and military applications due to its high cost. More realistically available TIMs are in the range of 2-8 W/mK with ultra-thin applications

whereas the metal parts they can connect are often well over 100 W/mK. These traditional TIMs are often silicone based with matrix materials embedded in them, including but not limited to aluminum, silver, and gold.¹¹ The reason thermal greases are often chosen in industry applications is because the grease is easy to apply and is easy to repair while still having good thermal conductivity.^{15,16} This helps keep manufacturing consistent, reliable, and fast. The issue with thermal greases is that they are prone to “pump-out,” or being forced out of place due to the difference in thermal expansion coefficients causing the two materials to slowly push the grease out as they heat and cool over time.¹⁷ Due to this issue, thermal pads are a simpler option to use when the interface setup allows. In addition, thermal pads can be manufactured to a consistent thickness and allow for easily repeatable installations whereas grease needs to be measured out and applied a certain way for consistent, repeated applications. This lead us to choose thermal pads for our research over thermal greases.

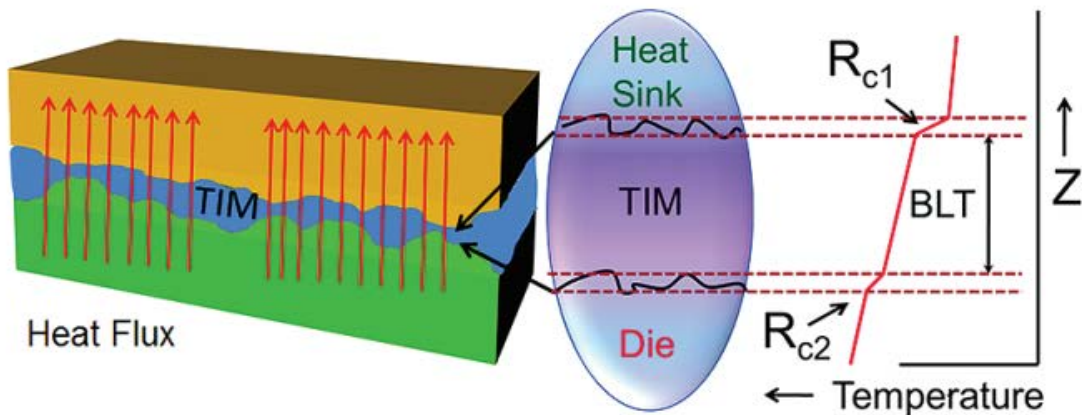

Figure 1.1 Schematic illustrating the action of thermal interface material, which fills the gaps between two contacting surfaces. The heat removal improves with higher thermal conductivity, smaller bond line thickness and contact resistance of the material. ¹

1.2 Current Research into TIM Improvement

We hope to create a TIM with a high thermal conductivity but that is much cheaper and easier to manufacture. One of the most commonly known research fields is the use of carbon nanotubes to create polymers with higher conductivity, but as in the case of Jones et.al, the composite is also electrically conductive.¹⁴ As mentioned previously, the most common TIMs are electrically insulative to ensure electrical component functionality is not compromised. Other research into this field has included the use of lithography, or stenciling the required conductive pattern onto a substrate.¹² This method is effective, but it is slow and is rather costly, so another method was needed. Fassler et. al. mixed liquid metal (LM) into PDMS and created elastic pads.¹³ This is the base method used for this research as it allows for consistent repeatability and quick turnaround of samples for testing.

The main idea behind this method of creating TIMs is using higher conductivity materials in conjunction with elastic polymers to create a thermally conductive and electrically insulative pads that conduct heat well when compressed. We are using galinstan, a gallium-indium-tin eutectic that is a liquid at -19C, in conjunction with Polydimethylsiloxane (PDMS) and matrix particles to create these pads. The idea is that the galinstan, when mixed with the PDMS forms a matrix of liquid metal droplets that can deform and respond to pressure. This allows for a flexible connection between the two components that is not compromised but uneven loading or shifting. As the pad is compressed, the liquid metal droplets in the elastic matrix come into contact with each other, forming a network through which heat can travel while still being electrically insulative due to the PDMS on the outside. In order to enhance this network, particles

such as alumina, graphite, copper and diamond can be added to act as the main thermal transport material while the liquid galinstan acts as a solder to connect all the particles.

Determining the proper manufacturing technique has been one of the main challenges as the surface tension of galinstan is about ten times that of water, meaning it does not want to mix into the viscous PDMS. At first, a mortar and pestle were used to combine the two, but the droplet size was inconsistent and the pads would leak liquid metal at higher volume percents. This led to the use of a high-speed mixing device and a brush to create microdroplets of material and evenly disperse it into the PDMS. This was successful, leading to the addition of other particles into the composite. As stated before, we are experimenting with the use of alumina, graphite, copper and diamond.

The use of copper microspheres led to further experimentation of the solid-solder matrix idea where the copper spheres are coated in galinstan and then embedded into the matrix material. Both mechanical and chemical deposition methods are being experimented with currently and the results of these TIMs are still in the works.

CHAPTER 2

Quantification of TIM Properties Via a Stepped Bar Apparatus

2.1 Quantification of TIM Properties

This brings up the next step of the process: how to quantify each of the various TIMs created? We recreated a stepped bar apparatus (SBA) as depicted in Thompson et. al.'s paper following the ASTM D5470 (Standard Test Method for Thermal Transmission Properties of Thermally Conductive Electrical Insulation Materials) standard.^{2,3} The test is conducted through placing a sample between two meter, or reference, bars of equal cross sectional area with polished surfaced while being compressed (Fig. 2a). A thermal gradient is imposed through heating one bar and cooling the other to a steady state value. The reference bars have thermocouples along their length inserted to the center of the bar to measure the temperature at known distances from the sample to compute the thermal gradient being imposed, allowing for the calculation of the thermal resistance of the material. The SBA works well for this as it essentially takes a three-dimensional pad and along with good insulation and powerful heating and cooling equipment, turns it into a one-dimensional heat flow problem. This allows for consistent measurement and quick results as the heat flow horizontally in the sample and in the system becomes negligible.

The SBA setup created is well equipped to find the thermal resistance of the sample and is easy to use, however, the thermal resistance value is significantly less valuable than thermal conductivity as thermal conductivity has more information about how thick the material is when used in a real-world application and because TIMs are presented in industry with a thermal conductivity rating. Initially, the initial thickness of the sample and the modulus of PDMS was used to estimate the thickness, but this quickly

become a large source of error. The samples are cast in a mold so they are not necessarily perfect to begin with and as the ratios of PDMS to fillers changes, the amount the material shrinks during curing changes as well. In addition, the filler materials (galinstan and particles) change the modulus of the material, making using the PDMS' modulus a poor choice.

In hopes of extracting the thickness of the sample during tested, the TIMs were subjected to compression testing on an Instron load frame to determine the strain at various pressures which were then used with the initial measurements to calculate the final thickness. The same size reference bars were used for the compression test as in the thermal testing to ensure proper numbers were being used. A load cell in the SBA provided constant force readings during thermal testing, however, there is hysteresis in the samples and the force fluctuates, sometimes greatly, as the TIM settles. This makes determining the actual thickness challenging as the thickness variation becomes a large part of the total thickness (>20%), especially as the samples are only about a half millimeter thick to being with. With both of these issues compounding, the extracted thickness cannot be taken as a real measurement for anything other than quickly checking the trend of the readings. It was determined that modifications to the system were needed to properly measure the thickness in situ.

This was accomplished by adding a linear encoder to the setup. A linear encoder is a magnetic based reader that can provide very precise location readings in real time; in our case, a 1 μ m resolution was selected to reduce the error from the measurement device. However, as the SBA setup was selected prior to needing the thickness readings, it had to be modified to accept the new instrumentation. This is where the majority of the work

came into play as the setup used was chosen to be inexpensive and easy to implement. The design of the SBA, its modifications, and proposed future design are discussed in the next section. Currently, the system has an error of approximately $\pm 10\mu\text{m}$.

2.2 Design and Modification of a SBA Apparatus

The SBA apparatus created is based off Thompson et. al.'s design, shown in figure 2. Minor design changes were made due to part availability and cost. As depicted in figure 2, we modified the ASTM D5470 standard (Fig. 2a) to account for misalignment between the two bars and machining error (Fig. 2b) in an effort to reduce the uncertainty of the system.^{2,18} This was accomplished through oversizing the top bar slightly to account for these errors as the costs to remedy them are relatively preventative as the error introduced by oversizing the bar does not significantly impact the results compared to the rest of the error in the system. We took this approach as well and modified them slightly to accommodate the ability of the machine shop, increasing the overall length and changing the thermocouple spacing slightly (Fig. 2c). It was also important that we use certified materials with tightly controlled compositions to ensure the thermal properties of the reference bars were well known. The first set of reference bars were made of 2024 aluminum that had the contact surfaces gold sputtered. This was done to protect the reference bars as galinstan reacts strongly with aluminum, causing oxidation and brittleness. The gold is about 15nm thick and as it was sputtered onto the surface, any thermal effects of the contact or thickness are negligible. Later, the bars were replaced with ones made with 110 copper and will be replaced again with a stainless-steel alloy. The material changes were chosen to deal with the oxidation factors as well as to reduce the thermal conductivity of the bars, allowing for thicker samples to be used.

The contact resistance was dealt with in two ways. First, the samples are compressed to relatively high loads, around 300N, to ensure that the contact between the sample and the polished reference bars was as perfect and consistent as possible. This helps to ensure that the contact resistance is essentially constant across all the samples and that the resistance measured is that of the sample and not the contact. Secondly, the contact resistance of the setup was found using samples with a well-defined thermal resistance. This provided a value through which we could use for rest of testing to calibrate the setup.

Figure 3 below shows the full system as it was designed and built to begin with, with its sole purpose being to measure thermal resistance. This design works extremely well in the sense that it was relatively quick and inexpensive to build, which was paramount to validating that adding liquid metal was indeed decreasing the thermal resistance of the pads. The system had a sleeve of thermal insulation that was clamped around the reference bars to negate convective heat transfer to the ambient air as much as possible. The foam used was cut to fit the setup and was then compressed using a spring steel clamp. The thermocouples used were high precision (0.4% accuracy) and were read by a control system from which MATLAB pulled the values for calculation. The MATLAB code used first went through a check to ensure the system had reached steady state through comparing multiple readings versus time and calculating when the change in the system has essentially reached zero.

Once the MATLAB code was finished and calibrated, our TIMs were tested using the SBA. They showed promise, but it became clear that the thickness measurement was now a large source of error when calculating the thermal conductivity, so changes to the

system needed to be made. A real-time thickness measurement was needed, and many options were explored before determining that a linear encoder was the best fit for what we needed and based on available funds, time to install and our current setup. It was determined that if we could get the thickness accuracy to $5\mu\text{m}$, then the error in the thickness is no longer the main error driving the thermal conductivity calculations.

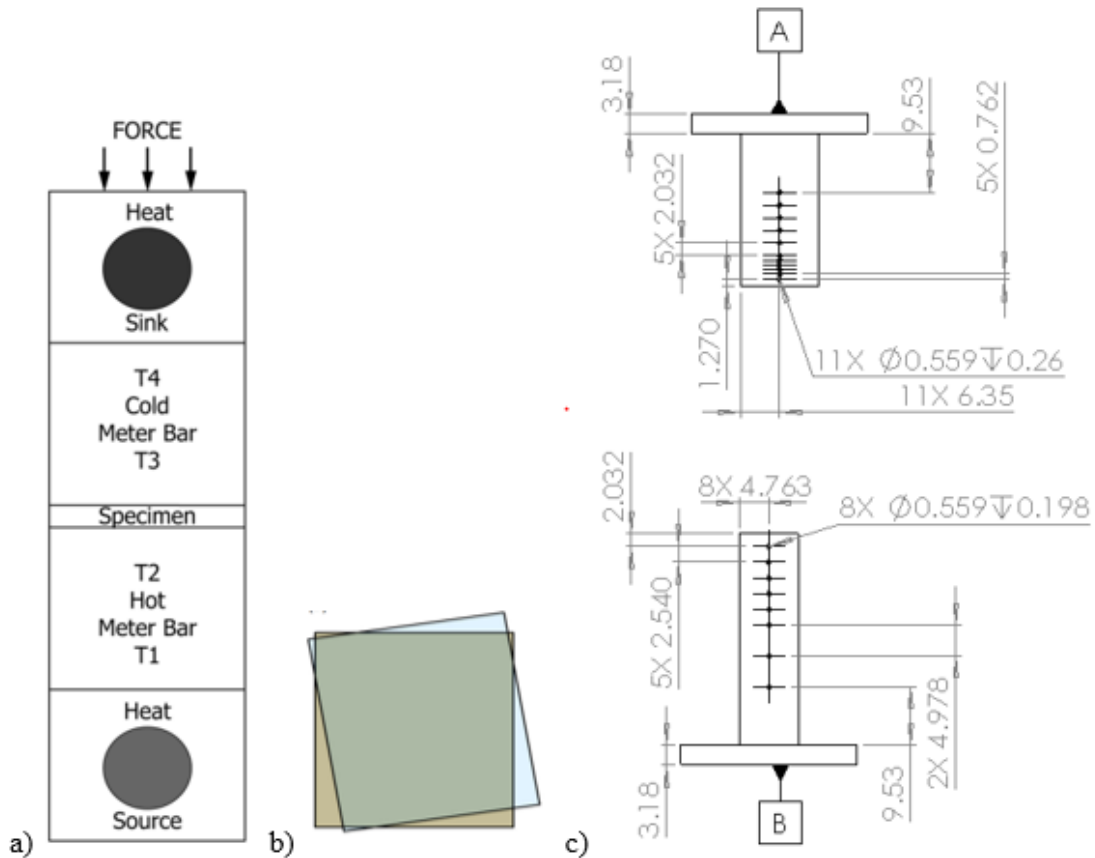

Figure 2.1 (a) ASTM D5470 thermal measurement setup.³ (b)¹ Potential misalignment shown in an exaggerated fashion if the bars were the same cross section. This would lead to a reduction in area for the heat flux, skewing results. (c) Schematics of the new reference bars (in mm) with [A] being the top (hot) and [B] being the bottom (cold). The

bars are square in profile and the thermocouple holes go to the center of the bars to ensure the readings are accurate.

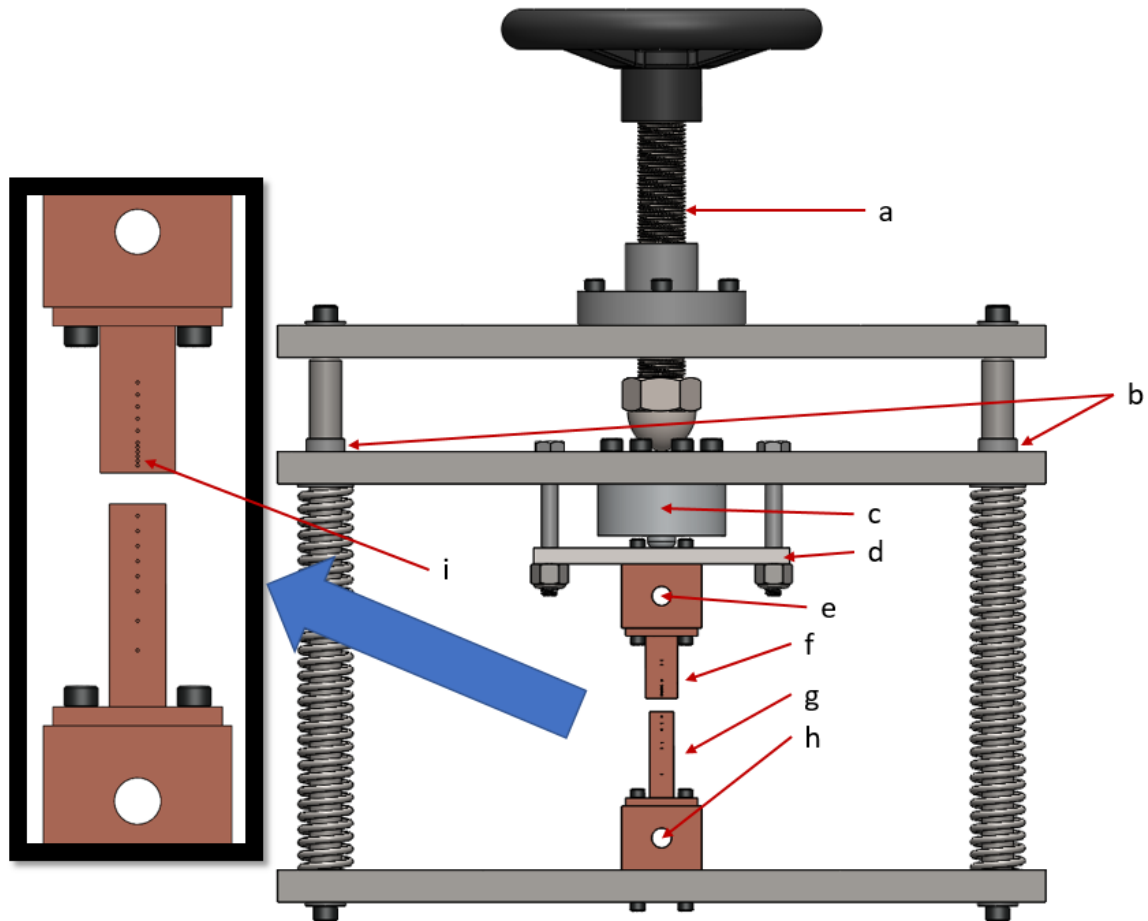

Figure 2.2 Depiction of our original SBA setup. Note: The system rests on rubber feet to insulate it from the table top. (a) ACME screw drive with hand wheel. (b) Teflon sleeve bearings, allowing the middle plate to slide smoothly on the support shafts. (c) 500N load cell. (d) Floating plate to allow for force reading while holding the upper reference bar assembly in place. (e) High temperature reservoir with hole for heating element. (f) Upper reference bar. (g) Lower reference bar. (h) Low temperature reservoir with hole for circulating cooling fluid. (i) Enlarged view of the reference bar setup with visible thermocouple holes.

We chose to use a linear encoder, Newall DMG-TT M, with a resolution of $1\mu\text{m}$ and mount it to the high temperature heat sink in an attempt to remove variation due to the load cell or floating plate deforming or twisting. Figure 4 below shows the modified setup. The linear encoder had to be offset from the reference bars quite a good distance due to the thermal insulation needed and its relative fragileness. The linear encoder references a carbon fiber rod filled with micro ball bearings using a magnetic field, so that rod could not be under other stresses without the risk of damaging or bending it, causing reader errors.

Once the machining was complete and the whole system installed, a critical issue arose. As the whole SBA was not precision machined on a CNC nor was there a way to perfectly align the full setup, the tolerances began to prove problematic. The sleeve bearings, which had worked very well before, were now causing significant error in our measurement system. When looking at the micron level of precision, bearings binding and plates being tenths of a degree from perfectly aligned became significant issues. Depending on how quickly the sample was compressed, the sleeve bearings would bind and then release in an uncontrolled manner, causing readings to fluctuate by up to 40 microns. Despite multiple attempts to align and lubricate the system to alleviate these issues, readings were still in the realm of $\pm 15\mu\text{m}$.

In addition, the cantilever setup provided problematic as the small floating plate would rotate slightly due to the weight. Correcting this took a fine balance of using the near side bolts holding the plate to lift the whole system up using the load cell as a pivot. This did put a bit of an initial force on the load cell, but it was relatively small. The issue with this became that any changes to the setup resulted in a full realignment being

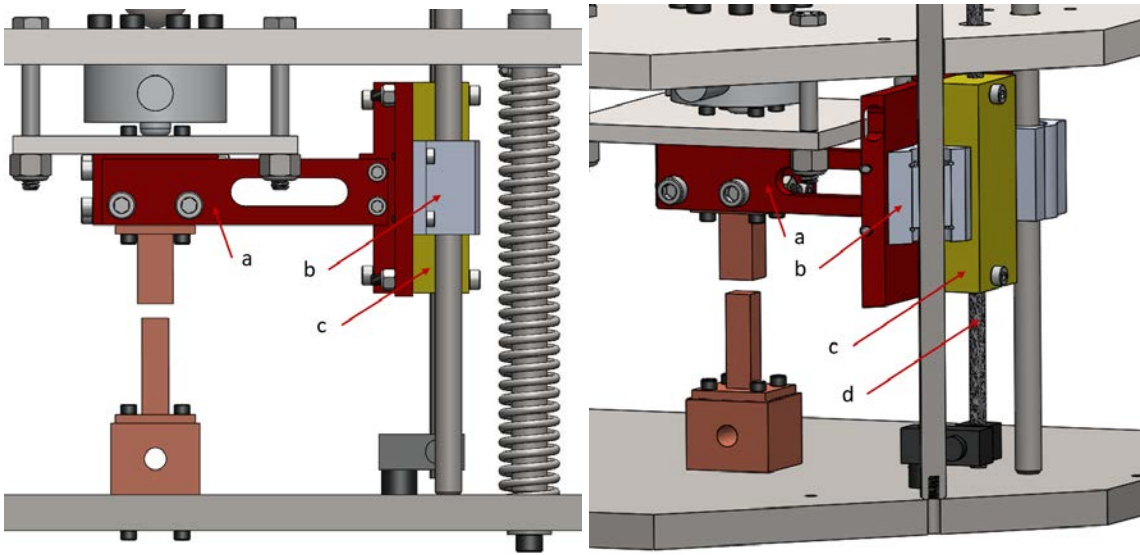

Figure 2.3 Left: Side view of the linear encoder setup. The support bars (a) connecting the high temperature reservoir to the linear encoder (c) are in red while the read head is in yellow (b). The linear bearings are sleeve bearings and ride on polished steel rails to help counteract cantilever forces and to protect the carbon fiber reference rod (hidden behind support shaft) from lateral or torsional forces due to thermal expansion and machining error. Right: Alternate view (d) is the carbon fiber reference rod.

needed, wasting time and providing questionable accuracy. Lastly, the sleeve bearings chosen for the mount would also occasionally bind slightly, causing the system to tilt and ruin both the reading and the alignment.

The alignment issues were never a problem when only thermal resistance was needed. This is because the floating plates were able to correct for misalignment as they were compressed and because it only needed to be aligned at the center of the device. Once the linear encoder was added, any tilt became overexaggerated by the increased weight and through the length of the mounting arm. A hundredth of a degree

misalignment at the plate went from 1 micron at the edge of the bar to almost 20 microns of error at the linear encoder head.

In order to rectify these issues, another round of modifications began, as shown in figure 5. A counterweight was added to address the misalignment issue and all the linear sleeve bearings were replaced with precision ball bearings. The ball bearings vastly reduced the binding issues, but there is still some residual force from the seals rubbing on the shafts. The SBA was also modified to allow the load cell to be removed and the whole setup become fixed to large steel plate. This ensures that as the sample is compressed, the best thickness reading possible, with the current design, is achieved. The force on the sample can be extracted from the thickness measurement given the testing data from the Instron load frame. The compressive force is a helpful number when describing the optimal operating conditions as this allows users to apply the proper force to the pad, be it through torquing the bolts that compress the two components or other means; but it has little relevance in quantifying the thermal characteristics of the TIM.

While this setup seems to be suboptimal, it actual is the best current option given what is currently available. Many other components were investigated but the linear encoder became the best option overall and modifications, including the encoder, were around \$2,000. When dealing with high resolution on a small scale, optical methods are generally the go-to option. Since we are dealing with elastic materials and working to reduce the model to one dimension, it was quickly determined that this method would not work for our needs. First, the TIM expands horizontally as it is compressed and spills over the top of the reference bars, obscuring the view of the sample. If the camera was backed up to measure, for example, a machined mark on each reference bar, then one

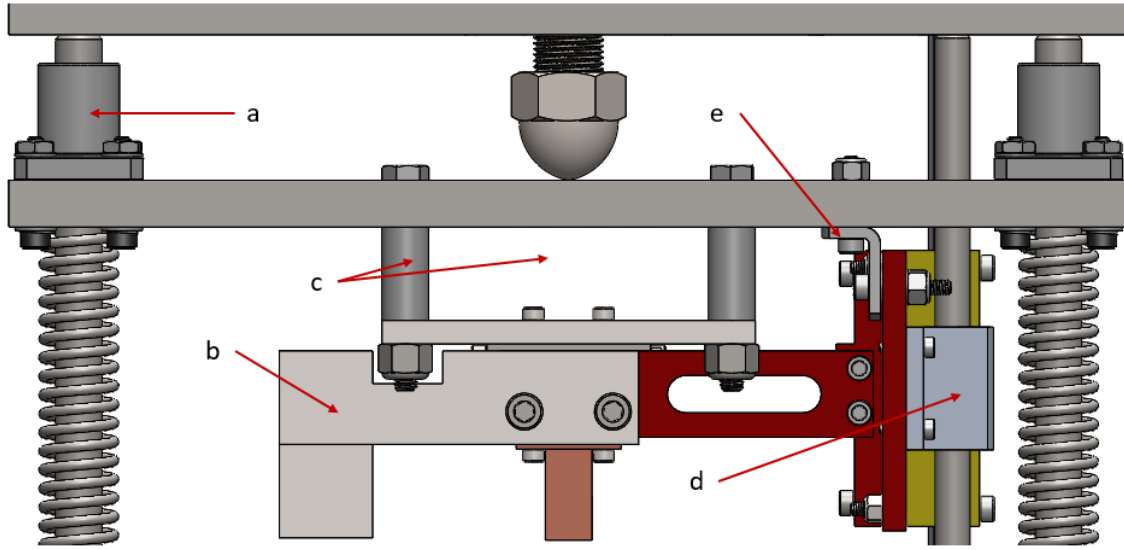

Figure 2.4 (a) Linear ball bearings were installed to replace the Teflon sleeve bearings. (b) Counterweight added to bring the center of gravity of the system back to the center of the reference bar to reduce tilting. (c) Spacers are added and the load cell is removed to anchor the whole system. (d) Ball bearings replace sleeve bearings here as well. (e) Brackets are added to mount the linear encoder to the middle plate for higher accuracy.

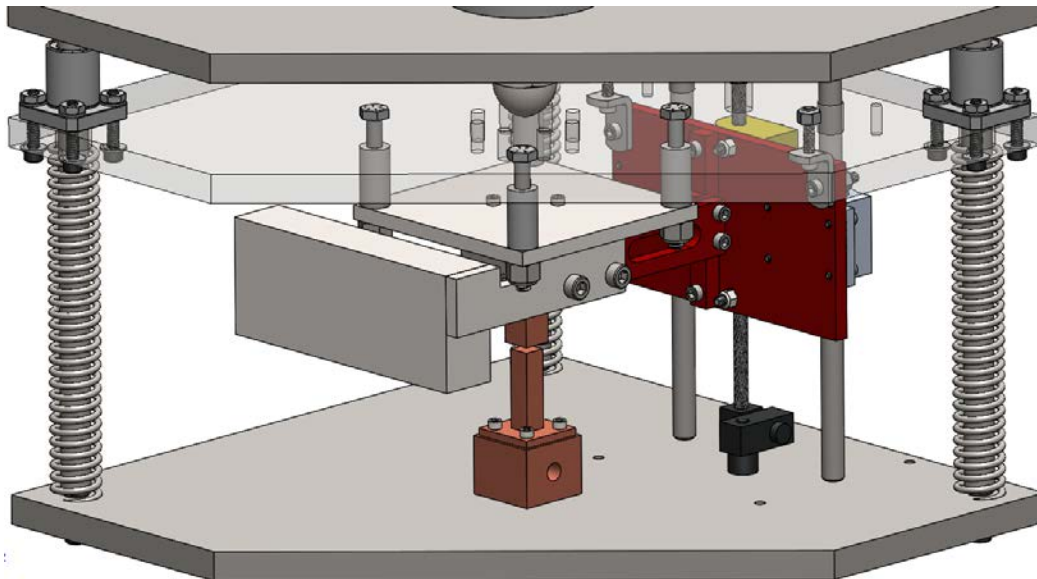

Figure 2.5 Isometric cross section of finalized modifications, showing counterweight profile as well as configured without the load cell.

encounters the issue of how to deal with the insulation issue. If the camera is extremely small and can be very close to the sample, insulation can be modified to accommodate a very small hole for the optics to fit into, but as the camera moves back, that opening must grow to allow for visibility, reducing the insulation and allowing for convective currents to form.

The alternative to the optical system was using a stepper motor to drive the main screw mechanism or replace the whole mechanism with a prefabricated one, however, our application is too unique. Stepper motors have great control over their rotational position, making them great for indexing locations. The issue with the stepper motor was that to get one powerful enough to overcome the spring force and the friction of the screw, they were extremely large and required a specialized controller able to put out the required amperage to power the unit. The way to get around this would have been using a reduction mechanism, be it a worm gear or gearbox to increase the motor torque. Now the job of figuring out how to mount the motor in such a way that still provides enough accuracy becomes very challenging and would have required the work and cost of basically redesigning the system, which was not an option at the time. Installing a linear actuator seemed to be a good work around for this issue, however, there were other issues as well. Linear actuators with the resolution desired were relatively expensive and would not be able to put enough force on the sample, often maxing out at 40N. The most powerful one was the Newport LTA-HL which topped out at 100N, still extremely short of the 350N target. If we were to order four of them and all the required controllers to be able to meet that load value, the cost would have been over \$12,000. On the contrary, ones that were powerful enough didn't have the precision needed to provide any useful

thickness information, unless, once again the cost skyrocketed. Even then, they still have a repeatability of $\pm 10\mu\text{m}$, such as the Thomson PC25 series, which is slightly larger than what we have achieved with the linear encoder. In addition, these parts often had large lead times and required extensive modification to the SBA for installation.

Another option explored was a vertical stage controlled by a micrometer, such as the Newport MVN120, which could handle the load required and was very precise. It could handle 400N and had an accuracy of $0.5\mu\text{m}$. This was quite promising, until its size and alignment was considered. The whole SBA would have to be overhauled to incorporate it properly, and the positioning of the stage becomes an issue. It is controlled by a high load, manual micrometer. When this is factored into the design, it becomes clear that reading the micrometer and controlling the system without further modification becomes difficult. The linear encoder has a digital readout that can be zeroed and provide travel distance whereas the micrometer requires the user to accurately read it when zeroing and when testing and then make sure to count the proper number of rotations to ensure correct readings. In addition, the alignment of the stage is fixed so while the linear encoder can be aligned to account for misalignment and machining error, the vertical stage cannot be adjusted for any of this. As a procedural tool, the linear encoder is the better choice, but these two instruments together could be an optimal design for future use.

In the future, if the SBA was to be modified again or fully rebuilt with a need for a thickness measurement in mind, the number of moving parts needs to be reduced significantly. A proposed design is shown below in figure 7. If a load cell is necessary, a flat plate load cell or cells that can be directly mounted to would greatly simplify the

problem. Currently there are two floating plates as depicted in figure 3, one to allow the reference bar to be raised or lowered and one to allow the load cell to register a value as it experiences strain. Ideally, one would take four low profile, direct mount load cells and affix them to a stiff, level plate. Then, one could mount the Newport vertical stage to the load cells, then have a mounting plate with a thermally insulative layer. On top of the insulation, you would then mount the low temperature heat sink and reference bar. Also, the linear encoder head could be mounted to this to provide the digital position readout to check the micrometer reading and provide positioning reference. The high temperature sink and reference bar would be sturdily suspended above the setup, again with a layer of thermal insulation, and would not move. The linear encoder rod would attach to the suspended structure to take any deflection from the load cells out of the thickness calculation. This would provide a very accurate reading of the thickness and pressure on the sample, but there is a decent amount of cost and machining involved.

This design is theoretically more beneficial than other designs currently used for the simple reason that the critical machining is done via precision CNC machines and that it is purpose built to be controlled via a calibrated instrument. There are other benefits that provide merit for this design, specifically, the stepped bar approach is the proper way to test the TIMs per ASTM D5470, and the use of mechanical measurement allows for the use of proper insulation. For example, in Székely et. al.'s⁴ TIM tester, they used the copper pyramid apparatus shown below in figure 9. It is an optical measuring system and is fully open to convective heat transfer. Kempers et. al.⁵ made a TIM tester using a similar setup to our SBA but with a linear actuator and controller capable of microstepping the motor. This allowed them to make sub-micron thickness adjustments,

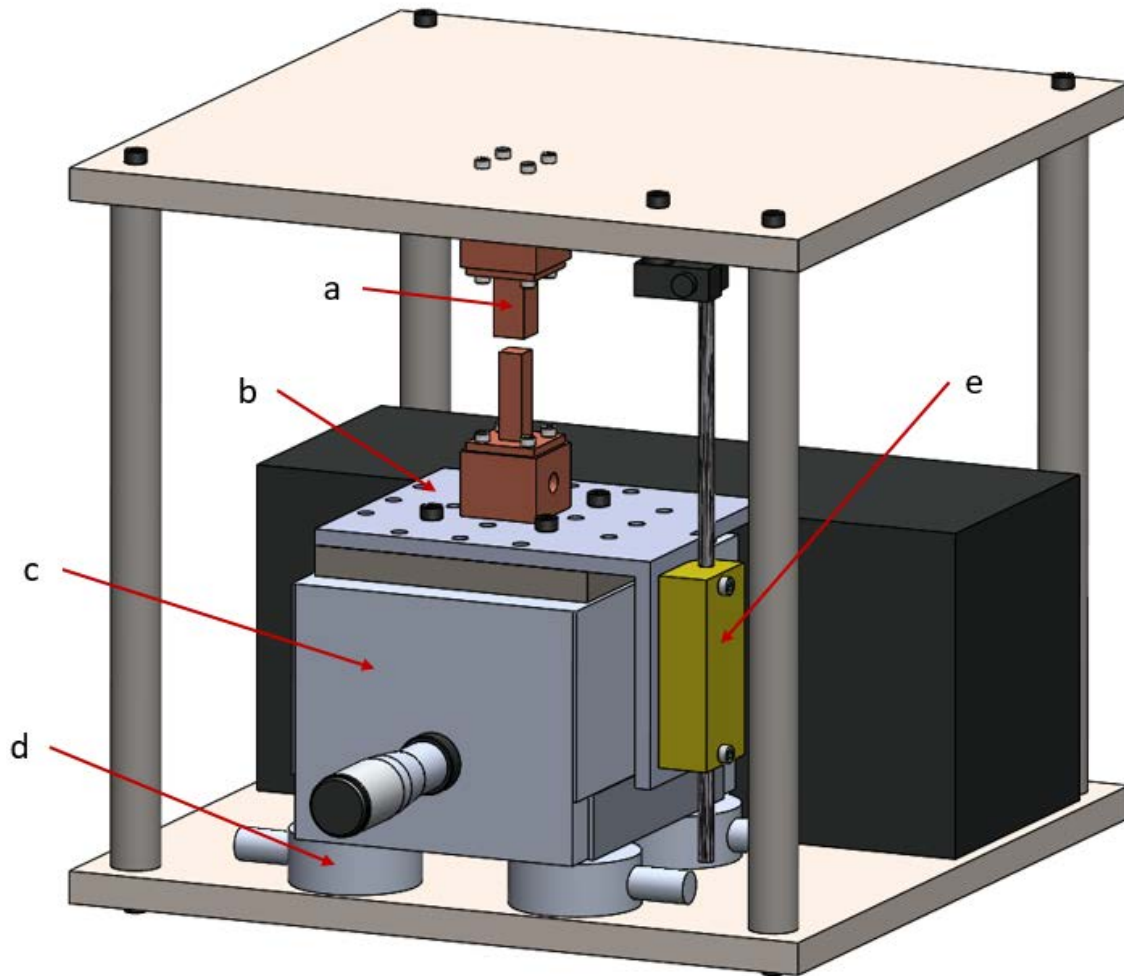

Figure 2.6 Basic proposed SBA 2.0 design. (a) Reference bars remain the same, upper one is fixed to the top plate. (b) Mounting plate with thermal insulation boundary between heat reservoir. Note the side bracket to mount the linear encoder head. (c) Newport MVN120 Vertical Stage with BM25.40 micrometer. (d) Array of low profile, direct mount load cells. (e) Linear encoder head, with reference rod mounted to the top plate. The black box at the back represents an area for control systems that are currently house outside of the SBA setup.

but once again, the cost for those components and lead times were significant factors. Other researchers^{6,7} have constructed similar SBA devices for quantifying TIMS but Murray et. al.⁸ took quite a new approach on how to construct the apparatus.

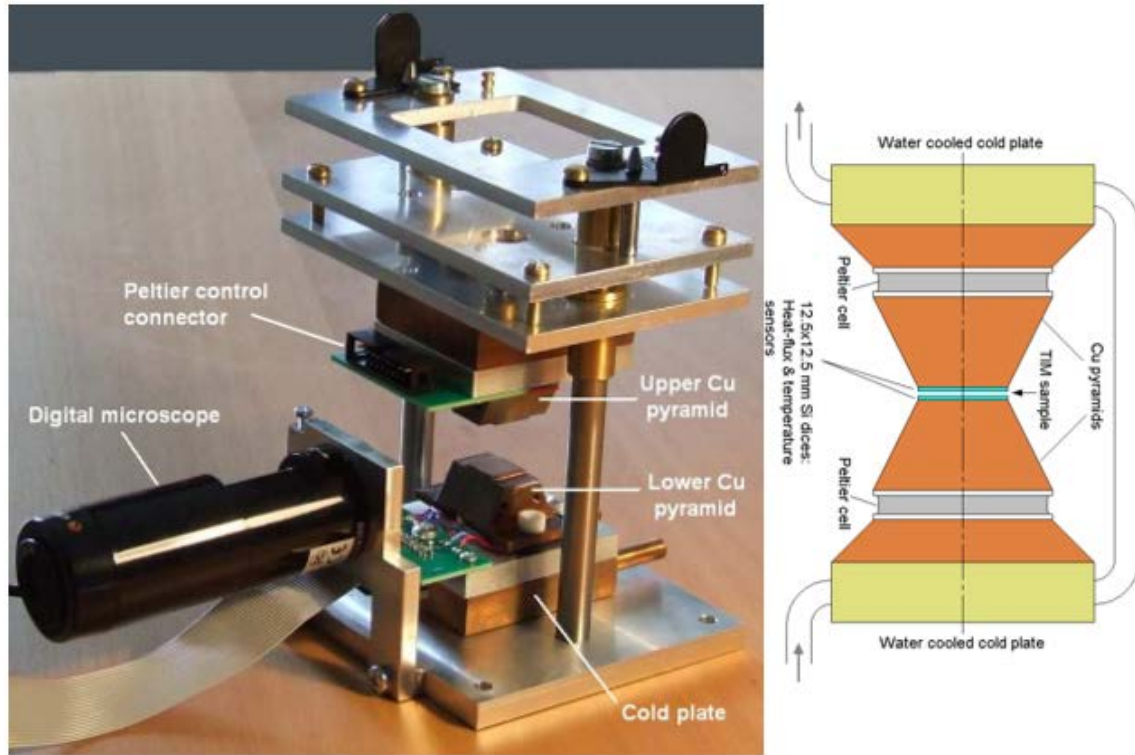

Figure 2.7 Copper pyramid TIM tester photograph and schematic.

Murray et. al.⁴ created a stepped bar apparatus that followed the ASTM D5470 standard but is controlled via a four-bar linkage and turnbuckles to create the proper alignment. In addition, the force applied to the sample is from actual weights placed atop the apparatus.

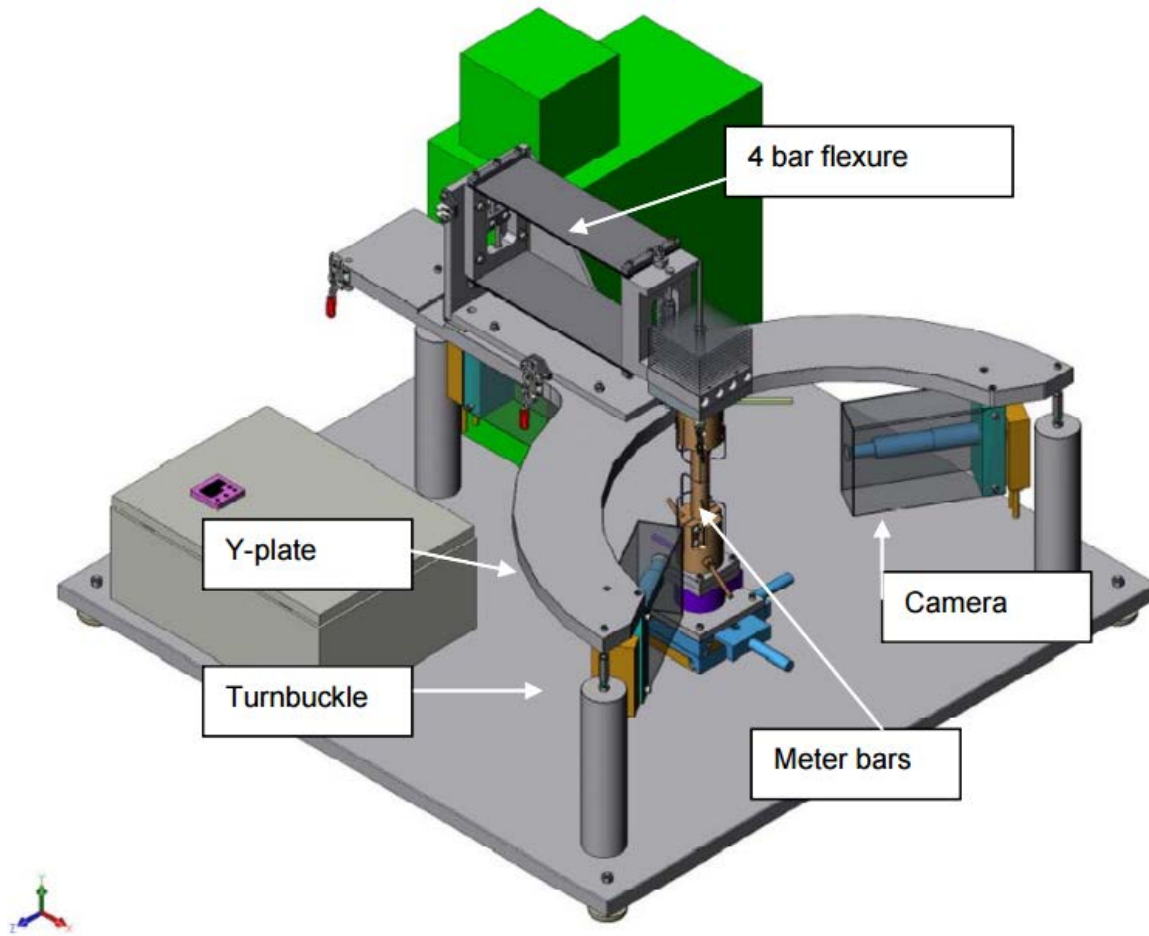

Figure 2.8 Schematic of Murray et. al.'s ⁸ SBA setup. Note that the force on the sample is provided from physically stacking more weight on top of the sample, with the max force being about 177N.

2.3 Thermal Considerations

Another critical element of the SBA setup is dealing with the thermal effects associated with having two temperature extremes. Thermal analysis from figure 11 shows that in the most extreme use case, the maximum error induced from thermal effects is about 70 μ m, but this is not a realistic value. For this situation to happen, the system

would have to have started at room temperature, been zeroed, then turned on. Once the heater and chiller were on, the system would have to sit for around 15 minutes to reach the maximum state of thermal shift possible for this setup. This is not how the device would actually be used, meaning that the realistic thermal error is in the realm of 5-10 μ m. The proper way to test a material would be to turn the SBA on, let it reach approximate thermal equilibrium, zero the linear encoder, then load the sample. The heat flux through the sample should be small enough that there is no significant thermal expansion or contraction that needs to be accounted for in the thickness calculation. Any recorded thermal shift could also be factored out through testing non-elastic materials with similar thermal conductivities and noting the thermal shift. This will be incorporated into the testing procedure once the TIM composite samples have been narrowed down to a certain ratio of fillers and a rough estimate of their conductivity has been achieved.

In addition to this, determining the proper material for the reference bars helps to tune the performance of the apparatus. As the apparatus works through measuring the thermal gradient being imposed, it is important that the reference bars are not so much more thermally conductive than the sample that there is no gradient, i.e. both bars are essentially evenly heated or cooled. As further tests were conducted, it was determined that thicker samples may provide better data, meaning that the heat flux through them would be lower. This has driven the need to reduce the thermal conductivity of the bars again, leading to the selection of stainless steel but a specific alloy has not yet been chosen.

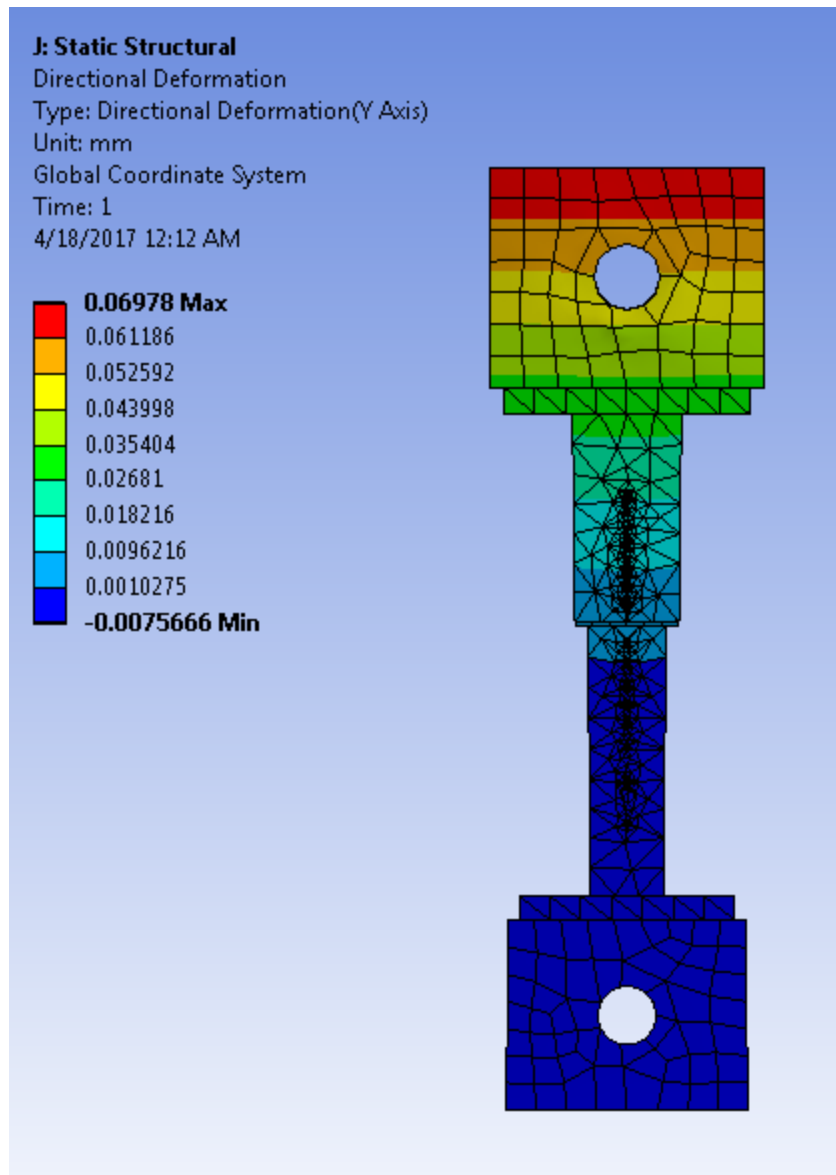

Figure 2.9 Thermal analysis showing the maximum thermal shift is around 70 μ m. This analysis assumes that the setup was zeroed at room temperature then turned on and left to reach steady state. In addition, this analysis uses the update stainless steel reference bars and has only 1N of force applied to the sample, showing the worst-case deformation.

CHAPTER 3

SBA User's Manual

3.1 Guide to Using the SBA

The current SBA setup requires the user to power on the chiller and heater and set their respective values. The values are saved from experiment to experiment and only need to be altered if different loading conditions are desired. When the heater setup is turned on, it also turns on the load cell and should display around 0N if there is no load being applied on the reference bars. If there is a relatively significant load shown (greater than ~10N), then the floating plate holding the reference bar is being pressed into the load cell via the four bolts. These bolts need to be loosened evenly to keep the reference bar level to ensure good contact. Then the linear encoder should be turned on and the upper platform lowered until the reference bars are touching with 100N of force. Allow the system to reach steady state and then zero the readout. This helps to reduce the error introduced into the measurements due to thermal expansion. At this point, reopen the reference bars and insert the sample. Close the reference bars, place the clamp with the insulation around the setup and apply the desired force to the sample. At this point, the MATLAB code should be run and it will determine when the sample has reached an approximate steady-state condition where measurements will be taken. It is important to note that once the desired TIM composite mixture has been determined, thermal effects on the thickness measurement should be factored out. This would be done by using a rigid material with similar thermal characteristics to the TIM and noting the steady state thermal drift of the measurement system.

3.2 SBA Disassembly and Reassembly Procedures

The SBA is relatively delicate in that the sensors are easily damaged by the heavy metal plates being used. In the event that the apparatus needs to be disassembled and modified, it is important to take the thermocouples out of the reference bars and the composite rod off of the linear encoder mount. The thermocouples slide out of their holes in the reference bars with a light pull, whereas the composite rod has a screw that holds it in place. Once the screw is loosened, the rod should slide out through the top of the apparatus. It may be a bit snug when being removed due to the tight tolerances. Place this in a safe location as it is quite fragile.

Once that is complete, remove the reference bars using a small hex key and set these aside as well. Now it is acceptable to remove a select component if desired, or for full disassembly, proceed by backing the drive screw out until there is no force on it from the middle plate. Then remove the four bolts holding the plate to the outer shafts and lift off the top plate. Then the floating plate and load cell can be removed from the middle plate. It is critical to be careful with the linear encoder head when removing the floating platform as damage to that is extremely costly. Once the load cell and floating plate assembly have been removed from the middle plate, it can be lifted off the shafts and set aside. Remove any bearings and hardware before machining any components. Then the posts and heat sink can be removed from the base plate. When reassembling the apparatus, proceed in reverse order. Make sure all parts are snug, but do not over tighten. This is especially critical when dealing with the copper blocks as the threads are very soft. It is a good idea to remove any thermal paste or debris from the bolts before

reinserting them into the copper. When reassembling the apparatus, clean any areas that had thermal paste and reapply a new layer to ensure a good contact.

CHAPTER 4

Conclusion

4.1 Conclusion

In our constantly changing, technological world, TIMs will play an ever-increasing role in our daily life. Improving them using liquid metals and forming stretchable composites opens a door to infinite possibilities, from strain gauges to heat sinks for flexible and wearable electronics. As these TIMs continue to improve and reduce in size, we must improve our ability to properly quantify their properties. The SBA approach as outlined in ASTM D5470 provides a mathematically simple and quick way to quantify these new materials but improvements on how to implement it will vastly help refine the proper path forward for improving TIMs. As thickness reduce and mechanical properties become more complex, more precise and controlled measurement techniques are needed. When we began testing the thermal resistance of the TIMs, some misalignment was acceptable and was easily compensated for, but as the samples grew thinner and the need for thermal conductivity became apparent, the system needed to be adapted to handle the new measurement hardware. While it is not a perfect fix, it is a beneficial interim solution that will provide key lessons for the creation of the next SBA version. Finding the right precision instruments for the application can be difficult as costs, lead times, and the sheer number of specialized components available can obscure the proper answer. In this case, it seems that using optical positioning equipment coupled with simple design will provide the best results in the end. The modifications made to the SBA provide enough information to use that to validate the new TIM composites and drive research forward until the time that a new apparatus is necessary.

REFERENCES

1. F, Shahil, Khan M KM (2012). "Graphene-multilayer graphene nanocomposites as highly efficient thermal interface materials". *Nano letters* (1530-6984), 12 (2), p. 861.
2. Thompson, Dakotah R. (2013). "A stepped-bar apparatus for thermal resistance measurements". *Journal of electronic packaging* (1043-7398), 135 (4), p. 041002.
3. ATSM (2006) "Standard Test Method for Thermal Transmission Properties of Thermally Conductive Electrical Insulating Materials," D5470, ASTM International, West Conshohocken, PA.
4. Székely, V. (2010). "Design of a Static TIM Tester". *Journal of electronic packaging* (1043-7398), 132 (1), p. 11001.
5. Kempers, R. (2008). "Development of a High-Accuracy Thermal Interface Material Tester". *International Journal of Heat and Mass Transfer*
6. Rencz, M. (2007). "Testing Interface Thermal Resistance." 9th Electronics Packaging Technology Conference. Ieee, 2007. 272-77
7. Kerns, D. (2003). "Improving Accuracy and Flexibility of ASTM D 5470 for High Performance Thermal Interface Materials". 19th IEEE Semi-Therm Symposium.
8. Murray, C.T. (2006). "Rumination on design and build of an ASTM D-5470 thermal interface test instrument" Proceedings of Thermal Conductivity 28/Thermal Expansion 16, DEStech Publication Inc, Lancaster, PA.
9. M. M. Yovanovich, E. E. Marotta, "Thermal spreading and contact resistances" in *Heat Transfer Handbook*, New Jersey, Hoboken, Wiley, pp. 261-395, 2003.
10. C. V. Madhusudana, *Thermal Contact Conductance*, New York, Springer-Verlag, 1996.
11. R. Mahajan, C.-P. Chiu, R. Prasher, "Thermal interface materials: A brief review of design characteristics and materials", *Electron. Cooling*, vol. 10, no. 1, 2004.
12. Wissman, James, Tong Lu, and Carmel Majidi. "Soft-matter electronics with stencil lithography." *SENSORS*, 2013 IEEE. IEEE, 2013.
13. Fassler, A. and Majidi, C. (2015), Liquid-Phase Metal Inclusions for a Conductive Polymer Composite. *Adv. Mater.*, 27: 1928–1932.
14. Jones, Wayne E. (2010). "Electrically and Thermally Conducting Nanocomposites for Electronic Applications". *Materials* (1996-1944), 3 (2), p. 1478.

15. S. Tonapi, K. Nagarkar, D. Esler, A. Gowda, "Reliability testing of thermal greases". Electronics Cooling Magazine, November 1st, 2007
16. A. Gowda, D. Esler, S.N. Paisner, S. Tonapi, Reliability testing of silicone-based thermal greases, in: Proc. 21st IEEE SEMI-THERM Symp., 2005, p. 64.
17. C.-P. Chiu, B. Chandran, M. Mello, K. Kelly, An accelerated reliability test method to predict thermal grease pump-out in flip-chip applications, in: Electronic Components and Technology Conference, Orlando, Florida, May 29–June 1, 2001.
18. Cola, B. A. (2014), "Towards reproducible ASTM D5470 measurements at lower cost," Electronic Cooling, Feb 2014.